



July 02, 2024

NOTICE OF BID
BL076-24
Purchase and Start-up of Submersible Pumps

The Gwinnett County Board of Commissioners is soliciting competitive sealed bids from qualified contractors for the **Purchase and Start-up of Submersible Pumps** for the Gwinnett County Department of Water Resources.

Bid submittal date and location

Bids should be typed or submitted in ink and returned in a sealed container marked on the outside with the BL# and Company Name. Bids will be received until **2:50 P.M. local time on August 02, 2024** at the Gwinnett County Purchasing Division, 75 Langley Drive, Lawrenceville, Georgia 30046. Any bid received after this date and time will not be accepted. Bids will be publicly opened and read at 3:00 P.M. Apparent bid results will be available the following business day on our website www.gwinnettcountry.com.

Project Description

Procurement and Start-up of submersible pumps to replace the Smith and Loveless induction pumps at seven (7) wastewater pump stations throughout Gwinnett County.

Instructions on Submitting Questions

Questions regarding bids should be directed to Brittany Bryant, Purchasing Associate II, at Brittany.Bryant@GwinnettCounty.com or by calling 770-822-7759, **no later than 3:00 P.M. on July 25, 2024**. Bids are legal and binding upon the bidder when submitted. All bids should be submitted in duplicate.

Bonding and Insurance

All contractors must submit with bid, a bid bond, certified check or cashier's check in the amount of five percent (5%) of the total bid. **Failure to submit a bid bond with the proper rating will result in the bid being deemed non-responsive.** Successful contractor will be required to meet insurance requirements, submit a one hundred percent (100%) performance bond and a one hundred percent (100%) payment bond. Insurance and Bonding Company should be licensed to do business by the Georgia Secretary of State, authorized to do business in Georgia by The Georgia Insurance Department, listed in the Department of Treasury's Publication of Companies holding Certificates of Authority as Acceptable Surety on Federal Bonds and as acceptable reinsuring companies. **The bid bond, payment bond, and performance bond must have an A.M. Best rating of A-V or higher.**

Facility Access

Gwinnett County does not discriminate on the basis of disability in the admission or access to its programs or activities. Any requests for reasonable accommodations required by individuals to fully participate in any open meeting, program or activity of Gwinnett County Government should be directed to the ADA Coordinator, Gwinnett County Justice and Administration Center, 770-822-8165.

The written bid documents supersede any verbal or written prior communications between the parties.

Award will be made to the contractors submitting the lowest responsive and responsible bid. Gwinnett County reserves the right to reject any or all bids to waive technicalities and to make an award deemed in its best interest. Bids may be split or awarded in entirety. Gwinnett County reserves the option to negotiate terms, conditions and pricing with the lowest responsive, responsible bidder(s) at its discretion.

Award notification will be posted after award on the County website, www.gwinnettcountry.com and companies submitting a bid will be notified via email.

We look forward to your bid and appreciate your interest in Gwinnett County.

Brittany Bryant, CPPB
Purchasing Associate III

BID CHECKLIST
Documents that should be submitted at the time of bid opening.

ITEM #	DESCRIPTION	PAGE #
1	Bid Schedule	4-6
2	Contractor Information	7
3	Bidder's Affidavit	8
4	Form of Non-Collusion Affidavit	9
5	References	10
6	List of Subcontractors	11
<u>7</u>	<u>Bid Bond (MUST BE SUBMITTED WITH BID)</u>	12
8	Contractor Affidavit and Agreement	41
9	Code of Ethics	42

FAILURE TO RETURN THIS PAGE AS PART OF YOUR BID DOCUMENT MAY RESULT IN REJECTION.

The bidder submits the following lump sums for the **Purchase and Start-up of Submersible Pumps** identified in Bid Form as part of this Bid. Bidder submits the following Lump Sum Bid Prices for furnishing pumps and control panels and providing start-up and testing services for multiple pump stations, identified as part of this Bid. Work included within each Bid Item is described in the Specifications. Payment for each Bid Item is described in Specification Section 01 22 15 – Measurement and Payment listed for that Bid Item. It should be noted the offered pumps must meet the performance requirements identified in the Specifications to be accepted as a viable bid. Bidders should submit pump curves with their bid for each pump station for which a bid is submitted. **Bidders are not required to offer bids for every pump station. Award may be made to one or multiple bidders based on the lump sum prices and the pump performance for the offered pumps.**

The Undersigned agrees to commence all preliminary and submittal work within 10 days of the date of Notice to Proceed issued by Gwinnett County Purchasing Office and to commit adequate resources to deliver the pumps and control panels with 150 days of return of approved submittals.

BID SCHEDULE

ITEM #	DESCRIPTION	LUMP SUM
1.	2000 West Place Pump Station including: <ul style="list-style-type: none"> • Submittals: \$ _____ • Pumps and Control Panel: \$ _____ • Pump Accessories: \$ _____ • Start-up, Testing, and Training Services: \$ _____ 	\$
2.	Centerville Road Pump Station <ul style="list-style-type: none"> • Submittals: \$ _____ • Pumps and Control Panel: \$ _____ • Pump Accessories: \$ _____ • Start-up, Testing, and Training Services: \$ _____ 	\$
3.	Millerbrook Pump Station <ul style="list-style-type: none"> • Submittals: \$ _____ • Pumps and Control Panel: \$ _____ • Pump Accessories: \$ _____ • Start-up, Testing, and Training Services: \$ _____ 	\$
4.	Mink Livsey Pump Station <ul style="list-style-type: none"> • Submittals: \$ _____ • Pumps and Control Panel: \$ _____ • Pump Accessories: \$ _____ • Start-up, Testing, and Training Services: \$ _____ 	\$

COMPANY NAME _____

FAILURE TO RETURN THIS PAGE AS PART OF YOUR BID DOCUMENT MAY RESULT IN REJECTION.
BID SCHEDULE CONTINUED

ITEM #	DESCRIPTION	LUMP SUM
5.	Northbrook #2 Pump Station <ul style="list-style-type: none"> • Submittals: \$ _____ • Pumps and Control Panel: \$ _____ • Pump Accessories: \$ _____ • Start-up, Testing, and Training Services: \$ _____ 	\$
6.	Roselake Pump Station <ul style="list-style-type: none"> • Submittals: \$ _____ • Pumps and Control Panel: \$ _____ • Pump Accessories: \$ _____ • Start-up, Testing, and Training Services: \$ _____ 	\$
7.	Southfork Pump Station <ul style="list-style-type: none"> • Submittals: \$ _____ • Pumps and Control Panel: \$ _____ • Pump Accessories: \$ _____ • Start-up, Testing, and Training Services: \$ _____ 	\$
OVERALL TOTAL (ITEMS 1 - 7)		\$

<u>DELIVERY SCHEDULE</u>	
Delivery of Pump and Control Panel Submittals:	_____ days from NTP
Delivery and Pumps, Accessories, and Control Panels:	_____ days from approval of Submittals

COMPANY NAME _____

FAILURE TO RETURN THIS PAGE AS PART OF YOUR BID DOCUMENT MAY RESULT IN REJECTION.

Pricing shall include all labor, materials, bailing, shoring, removal, a men's and women's temporary trailer (restroom and shower), overhead (Direct and indirect), profit, insurance, bonds, and other costs, to cover all finished Work.

Bidder agrees this Bid shall be good and may not be withdrawn for a period of sixty (60) calendar days after scheduled closing time for receiving bids.

There is enclosed herewith a certified or cashier's check or a Bid Bond to the order of Gwinnett County, Georgia, in the sum of Dollars _____

Check or Bid Bond shall be equal to, not less than, the amount stipulated in NOTICE TO BID and it is understood and agreed that said check or Bid Bond shall be subject to terms and conditions stipulated in Bid Document Package.

Undersigned Bidder hereby agrees to each and every stipulation in Bid Document Package pertaining to the submission of Bids and further, if awarded the Contract, duly agrees to execute and secure the required Contract and Bid Document Package within fifteen (15) days from service of Notice of Award and deliver a surety bond or bonds as required by General Conditions. The name and business address of Bidder to which all formal Notices shall be sent:

Undersigned Bidder states the names and addresses of persons interested as principals in this Bid are as follows: (Write first name in full):

Bidder shall state on line below, if a corporation, the name of State in which incorporated and the date of said incorporation:

Undersigned Bidder states (he/she/they) (is a/are) citizen(s) of the United States and all partners, associates, or principals interested herein are citizens of the United States, except: (Give full names and addresses):

FAILURE TO RETURN THIS PAGE AS PART OF YOUR BID DOCUMENT MAY RESULT IN REJECTION.

CONTRACTOR INFORMATION

The undersigned acknowledges receipt of the following addenda, listed by number and date appearing on each:

Addendum No.	Date	Addendum No.	Date
_____	_____	_____	_____
_____	_____	_____	_____

Certification Of Non-Collusion in Bid Preparation _____
(Signature) (Date)

The County requires that all who enter into a contract for the physical performance of services with the County must satisfy O.C.G.A. § 13-10-91 and Rule 300-10-1-.02, in all manner, and such are conditions of the contract.

In compliance with the attached specifications and O.C.G.A. §36-91-50, the undersigned offers and agrees, if this bid is accepted by the Board of Commissioners within sixty (60) days of the date of bid opening, to furnish any or all of the items upon which prices are quoted, at the price set opposite each item, delivered to the designated point(s) within the time specified in the bid schedule. By submission of this bid, I understand that Gwinnett County uses Electronic Payments for remittance of goods and services. Vendors should select their preferred method of electronic payment upon notice of award. For more information on electronic payments, please refer to the Electronic Payment information in the instructions to bidders.

Legal Business Name _____

Address _____

Does your company currently have a location within Gwinnett County? Yes No

Representative Signature _____

Print Authorized Representative's Name _____

Telephone Number _____ Fax Number _____

E-Mail Address _____

Contact Person (if someone other than the authorized representative listed above) _____

Telephone Number _____ Fax Number _____

E-Mail Address _____

BIDDER'S AFFIDAVIT

(This Bidder's Affidavit is part of the Bid Documents)

BID NUMBER: BL076-24

BID DATE: AUGUST 02, 2024

PROJECT NAME: PURCHASE AND START-UP OF SUBMERSIBLE PUMPS

STATE OF _____)

COUNTY OF _____)

(Name Printed)

being duly sworn, deposes and says that he resides at _____

that he is the

(Title)

(Name of Bidder)

who signed the above Bid Form, that he was duly authorized to sign and that the Bid is the true offer of the Bidder, that the seal attached is the seal of the Bidder and that all the declarations and statements contained in the Bid are true to the best of his knowledge and belief.

(Affiant)

Subscribed and Sworn to before me this _____ Day of _____ 20 _____

(Notary Public)

My Commission expires _____, 20 _____

(SEAL)

FAILURE TO RETURN THIS PAGE AS PART OF YOUR BID DOCUMENT MAY RESULT IN REJECTION.

REFERENCES

Gwinnett County requests a minimum of three (3) references where work of a similar size and scope has been completed.

Note: References should be customized for each project, rather than submitting the same set of references for every project bid. The references listed should be of similar size and scope of the project being bid on. Do not submit a project list in lieu of this form.

1. Company Name _____

Brief Description of Project _____

Completion Date _____

Contract Amount \$ _____ Start Date _____

Contact Person _____ Telephone _____

E-Mail Address _____

2. Company Name _____

Brief Description of Project _____

Completion Date _____

Contract Amount \$ _____ Start Date _____

Contact Person _____ Telephone _____

E-Mail Address _____

3. Company Name _____

Brief Description of Project _____

Completion Date _____

Contract Amount \$ _____ Start Date _____

Contact Person _____ Telephone _____

E-Mail Address _____

Company Name _____

FAILURE TO RETURN THIS PAGE AS PART OF YOUR BID DOCUMENT MAY RESULT IN REJECTION.

LIST OF SUBCONTRACTORS

I do _____, do not _____, propose to subcontract some of the work on this project.
I propose to Subcontract work to the following subcontractors:

NAME AND ADDRESS	TYPE OF WORK

Company Name _____

BID BOND

KNOW ALL MEN BY THESE PRESENTS: that

(Name of Contractor)

(Address of Contractor)

a _____
(Corporation, Partnership or Individual)

hereinafter called Principal, and

(Name of Surety)

(Address of Surety)

a Corporation of the State of _____, and a surety authorized by law to do business in the State of Georgia, hereinafter called Surety, are held and firmly bound unto

Gwinnett County Board of Commissioners
(Name of Obligee)

75 Langley Drive, Lawrenceville, Georgia 30046
(Address of Obligee)

Thereinafter referred to as Obligee: in the penal sum of _____

_____ Dollars

(\$ _____) in lawful money of the United States, for the payment of which sum will and truly to be made, we bind ourselves, our heirs, executors, administrators and successors, jointly and severally, firmly by these presents.

WHEREAS, the Principal is about to submit, or has submitted, to Gwinnett County, Georgia, a proposal for furnishing materials, labor, and equipment for: _____

WHEREAS, the Principal desires to file this Bond in accordance with law in lieu of a certified Bidder's check otherwise required to accompany this Proposal.

NOW, THEREFORE, the conditions of this obligation are such that if the proposal be accepted, the Principal shall within ten days after receipt of notification of the acceptance, execute a Contract in accordance with the Proposal and upon the terms, conditions, and prices set forth in the form and manner required by Gwinnett County, Georgia, and execute a sufficient and satisfactory Performance Bond and Payment Bond payable to Gwinnett County, Georgia, each in the amount of 100% of the total Contract Price, in form and with security satisfactory to said Gwinnett County, Georgia, and otherwise, to be and remain in full force and virtue in law, and the Surety shall, upon failure of the Principal to comply with any or all of the foregoing requirements within the time specified above, immediately pay to Gwinnett County, Georgia, upon demand, the amount hereof in good and lawful money of the United States of America, not as a penalty, but as liquidated damages.

PROVIDED, FURTHER, that Principal and Surety agree and represent that this bond is executed pursuant to and in accordance with the applicable provisions of the Official Code of Georgia Annotated, as Amended, including, but not limited to, O.C.G.A. § 36-91-1 et seq., and is intended to be and shall be constructed as a bond in compliance with the requirements thereof.

Signed, sealed and dated this _____ day of _____, A.D., 20_____.

ATTEST:

(Principal Secretary)
(SEAL)

(Principal)

By: _____

(Address)

(Witness as to Principal)

(Address)

ATTEST:

Resident or Nonresident Agent
(SEAL)

(Surety)

By: _____
(Attorney-in-Fact)

(Address)

(Witness as to Surety)

(Address)

NOTE: If Contractor is Partnership, all partners should execute Bond. Surety Companies executing Bonds must appear on the Treasury Department's most current list (Circular 570 as amended) and be authorized to transact business in the State where the Project is located.

Principal Secretary, Principal and Witness as to Principal signature lines must be signed by three different individuals. Additionally, Resident or Nonresident Agent, Witness as to Surety, and Attorney-in-fact must be signed by three different individuals.

**GENERAL CONDITIONS
FOR GWINNETT COUNTY CONSTRUCTION CONTRACTS**

GC-1 FAMILIARITY WITH SITE

Execution of this agreement by the Contractor is a representation that the Contractor has visited the site, has become familiar with the local conditions under which the work is to be performed, and has correlated personal observations with the requirements of this agreement.

GC-2 CONTRACT DOCUMENTS

This agreement consists of Gwinnett County's request for proposals, instructions to bidders, Contractor's proposal, construction contract, Performance Bond, Payment Bond, general conditions, special provisions, specifications, plans, drawings, addenda, and written change orders.

GC-3 DEFINITIONS

The following terms as used in this agreement are defined as follows:

Change Order - a written order to the Contractor, prepared by the Engineer and issued by the County for changes in the work within the general scope of the contract documents, adjustment of the contract price, extension of the contract time, or reservation of determination of a time extension.

County - Gwinnett County, Georgia, a political subdivision of the State of Georgia, acting by and through the Chairman of its Board of Commissioners.

Day - a calendar day of twenty-four hours lasting from midnight of one day to midnight the next day.

Notice to Proceed - written communication issued by the County to the Contractor authorizing it to proceed with the work and establishing the date of commencement and completion of the work.

Substantial Completion - the date certified by the engineer when all or a part of the work, identified in the engineer's certification, is sufficiently completed in accordance with the requirements of the contract documents so that the identified portion of the work can be utilized for the purposes for which it is intended.

Work - all of the services specified, indicated, shown or contemplated by the contract documents, and furnishing by the Contractor of all materials, equipment, labor, methods, processes, construction and manufacturing materials and equipment, tools, plans, supplies, power, water, transportation and other things necessary to complete such services in accordance with the contract documents to ensure a functional and complete facility.

GC-4 CODES

All codes, specifications, and standards referenced in the contract documents shall be the latest additions, amendments and revisions of such referenced standards in effect as of the date of the request for proposals for this contract.

GC-5 REVIEW OF CONTRACT DOCUMENTS

Before making its proposal to the County, and continuously after the execution of the agreement, the Contractor shall carefully study and compare the contract documents and shall at once report to the engineer any error, ambiguity, inconsistency or omission that may be discovered, including any requirement which may be contrary to any law, ordinance, rule, or regulation of any public authority bearing on the performance of the work. By submitting its proposal, the Contractor agrees that the

contract documents, along with any supplementary written instructions issued by or through the engineer that have become a part of the contract documents appear accurate, consistent and complete insofar as can be reasonably determined. If the Contractor has reported in writing any error, inconsistency, or omission to the County, has properly stopped the effected work until instructed to proceed, and has otherwise followed the instructions of the engineer, the Contractor shall not be liable to the County for any damage resulting from any such error, inconsistency, or omission in the contract documents. The Contractor shall not perform any portion of the work without the contract documents, approved plans, specifications, products and data, or samples for such portion of the work.

GC-6 STRICT COMPLIANCE

No observation, inspection, test or approval of the County or engineer shall relieve the Contractor from its obligation to perform the work in strict conformity with the contract documents.

GC-7 APPLICABLE LAW

All applicable State laws, County ordinances, and rules and regulations of all authorities having jurisdiction over the construction of the project shall apply to this agreement. All work performed within the right of way of the Georgia Department of Transportation shall be in accordance with DOT regulations, policies and procedures. The Contractor shall comply with all laws, ordinances, rules and regulations bearing on the conduct of the work as specified and the Contractor agrees to indemnify and hold harmless the County, its officers, agents and employees, as well as the engineer, against any claim or liability arising from or based on the violation of any law, ordinance, regulation, order or decree affecting the conduct of the work, whether occasioned by the Contractor, his agents or employees.

GC-8 PERMITS & LICENSES

All permits and licenses necessary for the work shall be secured and paid for by the Contractor. If any permit, license or certificate expires or is revoked, terminated, or suspended as a result of any action on the part of the Contractor, the Contractor shall not be entitled to additional compensation or time.

GC-9 TAXES

The Contractor shall pay all sales, retail, occupational, service, excise, old age benefit and unemployment compensation taxes, consumer, use and other similar taxes, as well as any other taxes or duties on the materials, equipment, and labor for the work provided by the Contractor which are legally enacted by any municipal, county, state or federal authority, department or agency at the time bids are received, whether or not yet effective. The Contractor shall maintain records pertaining to such taxes and levies as well as payment thereof and shall make the same available to the County at all reasonable times for inspection and copying.

GC-10 DELINQUENT CONTRACTORS

The County shall not pay any claim, debt, demand or account whatsoever to any person firm or corporation who is in arrears to the County for taxes. The County shall be entitled to a counterclaim and offset for any such debt in the amount of taxes in arrears, and no assignment or transfer of such debt after the taxes become due shall affect the right of the County to offset any taxes owed against said debt.

GC-11 LIEN WAIVERS

The Contractor shall furnish the County with evidence that all persons who have performed work or furnished materials pursuant to this agreement have been paid in full prior to submitting its demand

for final payment pursuant to this agreement. In the event that such evidence is not furnished, the County may retain sufficient sums necessary to meet all lawful claims of such laborers and materialmen. The County assumes no obligation nor in any way undertakes to pay such lawful claims from any funds due or that may become due to the Contractor.

GC-12 MEASUREMENT

All items of work to be paid for per unit of measurement shall be measured and certified by the Engineer.

GC-13 ASSIGNMENT

The Contractor shall not assign any portion of this agreement or moneys due therefrom without the prior written consent of the County. The Contractor shall retain personal control and shall provide personal attention to the fulfillment of its obligations pursuant to this agreement.

GC-14 FOREIGN CONTRACTORS

In the event that the Contractor is a foreign corporation, partnership, or sole proprietorship, the Contractor hereby irrevocably appoints the Secretary of State of Georgia as its agent for service of all legal process for the purpose of this contract only.

GC-15 INDEMNIFICATION

To the fullest extent permitted by law, the Contractor shall, at his sole cost and expense, indemnify, defend, satisfy all judgments, and hold harmless the County, the engineer, and their agents and employees from and against all claims, damages, actions, judgments, costs, penalties, liabilities, losses and expenses, including, but not limited to, attorney's fees arising out of or resulting from the performance of the work, provided that any such claim, damage, action, judgment, cost, penalty, liability, loss or expense (1) is attributable to bodily injury, sickness, disease, or death, or to injury to or destruction of tangible property (other than the work itself) including the loss of use resulting therefrom, and (2) is caused in whole or in part by any act or omission of the Contractor, any subcontractor, anyone directly or indirectly employed by any of them or anyone for whose acts any of them may be liable, regardless whether such claim is caused in part by a party indemnified hereunder. Such obligation shall not be construed to negate, abridge or otherwise reduce any of the rights or obligations of indemnity which would otherwise exist as to any party or person described in this agreement. In any and all claims against the County, the engineer, or any of their agents or employees by any employee of the Contractor, any subcontractor, anyone directly or indirectly employed by any of them, or anyone for whose acts any of them may be liable, the indemnification obligation contained herein shall not be limited in any way by any limitation on the amount or type of damages, compensation, or benefits payable by or for the Contractor or any subcontractor under Worker's Compensation Acts, disability benefit acts, or other employee benefit acts.

GC-16 SUPERVISION OF WORK

The Contractor shall supervise and direct the work using the Contractor's best skill and attention. The Contractor shall be solely responsible for all construction methods and procedures and shall coordinate all portions of the work pursuant to the contract subject to the overall coordination of the engineer. All work pursuant to this agreement shall be performed in a skillful and workmanlike manner.

GC-17 RESPONSIBILITY FOR WORK

The Contractor shall not be relieved from the Contractor's obligations to perform the work in accordance with the contract documents by the activities or duties of the engineer, including inspections, tests or approvals required or performed pursuant to this agreement.

GC-18 RESPONSIBILITY FOR ACTS OF EMPLOYEES

The Contractor shall be responsible to the County for the acts and omissions of its employees, subcontractors, and agents as well as any other persons performing work pursuant to this agreement. All areas within the limits of the Project which are determined by the Engineer to be unnecessarily damaged, due either directly or indirectly to the process of construction, shall be responsibility of the Contractor to correct and repair. This is not a payment item and shall be done without additional compensation.

GC-19 PAYMENT FOR LABOR AND MATERIALS

Unless otherwise provided in this agreement, the Contractor shall provide and pay for all labor, materials, equipment, tools, construction equipment and machinery, water, heat, utilities, transportation, and other facilities and services necessary for the execution and completion of the work.

GC-20 DISCIPLINE ON WORK SITE

The Contractor shall enforce strict discipline and good order among its employees and subcontractors at all times during the performance of the work. The Contractor shall not employ any subcontractor who is not skilled in the task assigned to it. The engineer may, by written notice, require the Contractor to remove from the work any subcontractor or employee deemed by the engineer to be incompetent.

GC-21 HOURS OF OPERATION

All work at the construction site shall be performed during regular business hours, except upon the engineer's prior written consent to other work hours.

GC-22 FAMILIARITY WITH WORK CONDITIONS

The Contractor shall take all steps necessary to ascertain the nature and location of the work and the general and local conditions, which may affect the work or the cost thereof. The Contractor's failure to fully acquaint itself with the conditions which may affect the work, including, but not limited to conditions relating to transportation, handling, storage of materials, availability of labor, water, roads, weather, topographic and subsurface conditions, other separate contracts to be entered into by the County relating to the project which may affect the work of the Contractor, applicable provisions of law, and the character and availability of equipment and facilities necessary prior to and during the performance of the work shall not relieve the Contractor of its responsibilities pursuant to this agreement and shall not constitute a basis for an equitable adjustment of the contract terms. The County assumes no responsibility for any understandings or representations concerning conditions of the work made by any of its officers, agents, or employees prior to the execution of this agreement.

GC-23 RIGHT OF ENTRY

The County reserves the right to enter the site of the work by such agent as it may elect for the purpose of inspecting the work or installing such collateral work as the County may desire.

GC-24 NOTICES

Any notice, order, instruction, claim or other written communication required pursuant to this agreement shall be deemed to have been delivered or received as follows:

- (1) Upon personal delivery to the Contractor, it's authorized representative, or the engineer on behalf of the County. Personal delivery may be accomplished by in-person hand delivery or bona fide overnight express service.

(2) Three days after depositing in the United States mail a certified letter addressed to the Contractor, the County, or the engineer. For purposes of mailed notices, the County's mailing address shall be 75 Langley Drive, Lawrenceville, Georgia 30046. The Contractor's mailing address shall be the address stated in its proposal, and the engineer's mailing address shall be its address listed in the Notice to Begin Work.

GC-25 SAFETY

The Contractor shall take all reasonable precautions for the safety of all persons and property associated with the work, and the Contractor shall erect and maintain, as required by existing conditions and the progress of the work, all reasonable safeguards for the safety and protection of persons in the vicinity of the project.

GC-26 BLASTING AND EXCAVATION

The Contractor acknowledges that it is fully aware of the contents and requirements of O.C.G.A. § 25-9-1 through 25-9-12 concerning blasting and excavation near underground gas pipes and facilities and shall fully comply therewith.

GC-27 HIGH VOLTAGE LINES

The Contractor acknowledges that it is fully aware of the contents and requirements O.C.G.A. § 46-3-30 through 46-3-39 concerning safeguards against contact with high voltage lines, and the Contractor shall fully comply with said provisions.

GC-28 SCAFFOLDING AND STAGING

The Contractor acknowledges that it is the person responsible for employing and directing others to perform labor within the meaning of O.C.G.A. § 34-1-1 and agrees to comply with said provisions.

GC-29 CLEAN-UP

The Contractor shall clean up all refuse, rubbish, scrap materials, and debris caused by its operations to the end that the site of the work shall present a neat, orderly and workmanlike appearance at all times.

GC-30 PROTECTION OF WORK

The Contractor shall be responsible for maintenance and protection of the work until final completion of this agreement and acceptance of the work as defined herein. Any portion of the work suffering injury, damage or loss shall be considered defective and shall be corrected or replaced by the Contractor without additional cost to the County.

GC-31 REJECTED WORK

The Contractor shall promptly remove from the project all work rejected by the engineer for failure to comply with the contract documents and the Contractor shall promptly replace and re-execute the work in accordance with the contract documents and without expense to the County. The Contractor shall also bear the expense of making good all work of other Contractors destroyed or damaged by such removal or replacement.

GC-32 DEFECTIVE WORK

If the Contractor defaults or neglects to carry out any portion of the work in accordance with the contract documents, and fails within three days after receipt of written notice from the County or the engineer to commence and continue correction of such default or neglect with diligence and promptness, the County or the engineer may, after three days following receipt by the Contractor of an additional written notice and without prejudice to any other remedy the County may have, make good such deficiencies and complete all or any portion of any work through such means as the

County may select, including the use of a new Contractor. In such case, an appropriate change order shall be issued deducting from the payments then or thereafter due the Contractor the cost of correcting such deficiencies. In the event the payments then or thereafter due the Contractor are not sufficient to cover such amount, the Contractor shall pay the difference to the County on demand.

GC-33 NEW MATERIALS

The Contractor warrants to the County that all materials and equipment furnished under this contract will be new unless otherwise specified, and the Contractor further warrants that all work will be of good quality, free from faults and defects, and in conformance with the contract documents. The warranty set forth in this paragraph shall survive final acceptance of the work.

GC-34 CONTRACTOR'S WARRANTY

If within one year after the date of substantial completion and final acceptance of the work by the County, or within such longer period of time as may be prescribed by law or by the term of any applicable special warranty required by the contract documents, any of the work is found to be defective or not in accordance with the contract documents, the Contractor shall correct such work promptly after receipt of written notice from the County to do so. This obligation shall survive both final payment for the work and termination of the contract.

GC-35 ASSIGNMENT OF MANUFACTURERS' WARRANTIES

Without limiting the responsibility or liability of the Contractor pursuant to this agreement, all warranties given by manufacturers on materials or equipment incorporated in the work are hereby assigned by the Contractor to the County. If requested, the Contractor shall execute formal assignments of said manufacturer's warranties to the County. All such warranties shall be directly enforceable by the County.

GC-36 WARRANTIES IMPLIED BY LAW

The warranties contained in this agreement, as well as those warranties implied by law, shall be deemed cumulative and shall not be deemed alternative or exclusive. No one or more of the warranties contained herein shall be deemed to alter or limit any other.

GC-37 STOP WORK ORDERS

In the event that the Contractor fails to correct defective work as required by the contract documents or fails to carry out the work in accordance with contract documents, the County, or the engineer, in writing, may order the Contractor to stop work until the cause for such order has been eliminated. This right of the County or engineer to stop work shall not give rise to any duty on the part of the County or the engineer to execute this right for the benefit of the Contractor or for any other person or entity.

GC-38 TERMINATION FOR CAUSE

If the Contractor is adjudged bankrupt, makes a general assignment for the benefit of creditors, suffers the appointment of a receiver on account of its insolvency, or fails to supply sufficient properly skilled workers, materials, fails to make prompt payment to subcontractors or materialmen, disregards laws, ordinances, rules, regulations, or orders of any public authority having jurisdiction, or is otherwise guilty of a material violation of this agreement and fails within seven days after receipt of written notice to commence and continue correction of such default, neglect, or violation with diligence and promptness, the County may, after ten days following receipt by the Contractor of an additional written notice and without prejudice to any other remedy the County may have, terminate the employment of the Contractor and take possession of the site as well as all materials, equipment, tools, construction equipment and machinery thereon. The County may finish the work

by whatever methods the County deems expedient. In such case, the Contractor shall not be entitled to receive any further payment until the work is completed. If the unpaid balance of the contract price exceeds the cost of completing the work, such excess shall be paid to the Contractor. If such costs exceed the unpaid balance, the Contractor shall pay the difference to the County on demand. This obligation for payment shall survive the termination of the contract. Termination of this agreement pursuant to this paragraph may result in disqualification of the Contractor from bidding on future County contracts.

GC-39 TERMINATION FOR CONVENIENCE

The County may, at any time upon 30 days written notice to the Contractor, terminate the whole or any portion of the work for the convenience of the County. Said termination shall be without prejudice to any right or remedy of the County provided herein. In addition, in the event this agreement has been terminated due to the default of the Contractor, and if it is later determined that the Contractor was not in default pursuant to the provisions of this agreement at the time of termination, then such termination shall be considered a termination for convenience pursuant to this paragraph.

GC-40 TERMINATION FOR CONVENIENCE - PAYMENT

In the event that the County terminates this agreement for the convenience of the County, the County shall only be liable to the Contractor for those costs reimbursable to the Contractor plus a mark-up of ten percent on the actual fully accounted cost recovered pursuant to this paragraph. In the event that it appears that the Contractor would have sustained a loss on the entire contract had it been completed, no profit shall be included or allowed hereunder and an appropriate adjustment shall be made reducing the amount of settlement to reflect the indicated rate of loss. In the event of termination for the convenience of the County, the County shall pay the Contractor the following amounts determined by the engineer:

- A. An amount for supplies, services, or property accepted by the County for which payment has not previously been made. The price to be paid for these items shall be equivalent to the aggregate price for such supplies or services computed in accordance with the price specified in this agreement appropriately adjusted for any saving of freight or other charges; and
- B. The total of:
 - (1) The costs incurred in the performance of the work terminated, including initial costs and preparatory expenses allocable thereto, but exclusive of any costs attributable to supplies or services previously paid;
 - (2) The costs of settling and paying claims arising pursuant to the termination of the work under said contracts or orders which are properly chargeable to the terminated portion of the contract (exclusive of the amounts paid or payable on account of completed items or equipment delivered or services furnished by a subcontractor or vendor prior to the effective date of the notice of termination, which amounts shall be included in the costs payable pursuant to (A)); and
 - (3) The reasonable costs of settlement, including accounting, legal, clerical, and other expenses reasonable and necessary for the preparation of settlement claims and supporting data with respect to the terminated portion of the contract and for the termination and settlement of subcontracts thereunder, together with reasonable

storage, transportation, and other costs incurred in connection with the protection or disposition of property allocable to this agreement.

GC-41 TERMINATION FOR CONVENIENCE - PAYMENT LIMITATIONS

In the event of termination for the convenience of the County, the total sum to be paid to the Contractor shall not exceed the contract price as reduced by the amount of payments otherwise made, by the contract price for work not terminated, and as otherwise permitted by the contract. Except for normal spoilage, and except to the extent that the County shall have otherwise expressly assumed the risk of loss, there shall be excluded from the amounts payable to the Contractor the fair value, as determined by the engineer, of property which is destroyed, lost, stolen or damaged so as to become undeliverable to the County or to another buyer.

GC-42 COST TO CURE

If the County terminates the whole or any part of the work pursuant to this agreement, then the County may procure upon such terms and in such manner as the engineer may deem appropriate, supplies or services similar to those so terminated, and the Contractor shall be liable to the County for any excess costs for such similar supplies or services. The Contractor shall continue the performance of this agreement to the extent not terminated hereunder.

GC-43 ATTORNEY'S FEES

Should the Contractor default pursuant to any of the provisions of this agreement, the Contractor and its surety shall pay to the County such reasonable attorney's fees as the County may expend as a result thereof and all costs, expenses, and filing fees incidental thereto.

GC-44 CONTRACTOR'S RESPONSIBILITIES UPON TERMINATION

After receipt of a notice of termination from the County, and except as otherwise directed by the engineer, the Contractor shall:

1. Stop work under the contract on the date and to the extent specified in the notice of termination;
2. Place no further orders or subcontracts for materials, services or facilities, except as may be necessary for completion of such portion of the work under the agreement as is not terminated;
3. Terminate all orders and subcontracts to the extent that they relate to the performance of work terminated by the notice of termination;
4. Assign to the County in the manner, at the times, and to the extent directed by the engineer, all of the rights, title and interest of the Contractor under the orders and subcontracts so terminated, in which case the County shall have the right, at its discretion, to settle or pay any and all claims arising out of the termination of such orders or subcontracts;
5. Settle all outstanding liabilities and all claims arising out of such termination of orders and subcontracts, with the approval or ratification of the engineer, to the extent the engineer may require, which approval or ratification shall be final for all purposes;
6. Transfer title and deliver to the entity or entities designated by the County, in the manner, at the times, and to the extent, if any, directed by the engineer, and to the

extent specifically produced or specifically acquired by the Contractor for the performance of such portion of the work as has been terminated:

- (a) The fabricated or unfabricated parts, work, and progress, partially completed supplies, and equipment, materials, parts, tools, dyes, jigs, and other fixtures, completed work, supplies, and other material produced as a part of or acquired in connection with the performance of the work terminated by the notice of termination; and
 - (b) The completed or partially completed plans, drawings, information, and other property to the work.
7. Use its best efforts to sell in the manner, at the times, to the extent, and at the prices directed or authorized by the engineer, any property described in Section 6 of this paragraph, provided, however, that the Contractor shall not be required to extend credit to any buyer and further provided that the proceeds of any such transfer or disposition shall be applied in reduction of any payments to be made by the County to the Contractor pursuant to this agreement.
 8. Complete performance of such part of the work as shall not have been terminated by the notice of termination; and
 9. Take such action as may be necessary, or as the engineer may direct, for the protection and preservation of the property related to the agreement which is in the possession of the Contractor and in which the County has or may acquire an interest.

GC-45 RECORDS

The Contractor shall preserve and make available to the County all of its records, books, documents and other evidence bearing on the costs and expenses of the Contractor and any subcontractor pursuant to this agreement upon three days advance notice to the Contractor.

GC-46 DEDUCTIONS

In arriving at any amount due the Contractor pursuant to the terms of this agreement, there shall be deducted all liquidated damages, advance payments made to the Contractor applicable to the termination portion of the contract, the amount of any claim which the County may have against the Contractor, the amount determined by the engineer to be necessary to protect the County against loss due to outstanding potential liens or claims, and the agreed price of any materials acquired or sold by the Contractor and not otherwise recovered by or credited to the County.

GC-47 REIMBURSEMENT OF THE COUNTY

In the event of termination, the Contractor shall refund to the County any amount paid by the County to the Contractor in excess of the costs reimbursable to the Contractor.

GC-48 TERMINATION FOR CONVENIENCE - DELAY

The Contractor shall be entitled to only those damages and that relief from termination by the County as specifically set forth in this agreement. The County or the engineer may issue a written order requiring the Contractor to suspend, delay or interrupt all or any part of the work for such period of time as the County may determine to be appropriate for the convenience of the County. If the performance of the work is interrupted for an unreasonable period of time by an act of the County or engineer in the administration of this agreement, an equitable adjustment shall be made for any increase in the Contractor's costs of performance and any increase in the time required for

performance of the work necessarily caused by the unreasonable suspension, delay, or interruption. Any equitable adjustment shall be reduced to writing and shall constitute a modification to this agreement. In no event, however, shall an equitable adjustment be made to the extent that performance of this agreement would have been suspended, delayed or interrupted by any other cause, including the fault or negligence of the Contractor. No claim for an equitable adjustment pursuant to this paragraph shall be permitted before the Contractor shall have notified the engineer in writing of the act or failure to act involved, and no claim shall be allowed unless asserted in writing to the engineer within ten days after the termination of such suspension, delay or interruption.

GC-49 COMMENCEMENT AND DURATION OF WORK

The Contractor shall commence work pursuant to this agreement within ten days of mailing or delivery of written notice to proceed by the County. The Contractor shall diligently prosecute the work to completion within the time specified therefore. The capacity of the Contractor's construction and manufacturing equipment and plan, sequence and method of operation and forces employed, including management and supervisory personnel, shall be such as to ensure completion of the work within the specified time. The Contractor and County hereby agree that the contract time for completion of the work is reasonable taking into consideration the average climatic conditions prevailing in the locality of the work.

GC-50 TIME OF THE ESSENCE

All time limits stated in this agreement are of the essence of this contract.

GC-51 IMPACT DAMAGES

Except as specifically provided pursuant to a stop work order or change order, the Contractor shall not be entitled to payment or compensation of any kind from the County for direct or indirect or impact damages including, but not limited to, costs of acceleration arising because of delay, disruption, interference or hindrance from any cause whatsoever whether such delay, disruption, interference or hindrance is reasonable or unreasonable, foreseeable or unforeseeable, or avoidable, provided, however, that this provision shall not preclude the recovery of damages by the Contractor for hindrances or delays due solely to fraud or bad faith on the part of the County its agents or employees. The Contractor shall be entitled only to extensions in the time required for performance of the work as specifically provided in the contract.

GC-52 DELAY

The Contractor may be entitled to an extension of the contract time, but not an increase in the contract price, for delays arising from unforeseeable causes beyond the control and without the fault or negligence of the Contractor or its subcontractors for labor strikes, acts of God, acts of the public enemy, acts of the state, federal or local government in its sovereign capacity, by acts of another separate contractor, or by an act of neglect of the County with the engineer.

GC-53 INCLEMENT WEATHER

The Contractor shall not be entitled to an extension of the contract time due to normal inclement weather. Unless the Contractor can substantiate to the satisfaction of the engineer that there was greater than normal inclement weather considering the full term of the contract using a ten year average of accumulated mean values for climatological data compiled by the U.S. Department of Commerce for Atlanta, Georgia and that such greater than normal inclement weather actually delayed the work, the Contractor shall not be entitled to an extension of time therefor.

GC-54 NOTICE OF DELAY

The Contractor shall not receive an extension of time unless a notice of a claim is filed with the County and the engineer within ten days of the first instance of such delay, disruption, interference or

hindrance and a written statement of the claim is filed with the engineer and the County within 20 days of the first such instance. In the event that the Contractor fails to comply with this provision, it waives any claim, which it may have for an extension of time pursuant to this agreement.

GC-55 NOTICE OF DELAY - CONTENTS

The notice of delay referenced in the preceding paragraph shall include specific information concerning the nature of the delay, the date of commencement of the delay, the construction activities affected by the delay, the person or organization responsible for the delay, the anticipated extent of the delay, and any recommended action to avoid or minimize the delay.

GC-56 PROGRESS OF WORK

To the extent that the Contractor is entitled to additional compensation for delay, an absolute condition precedent to such entitlement shall be strict compliance with all requirements and procedures for entitlement to an extension of time herein. If the work actually in place falls behind the currently updated and approved project network schedule, and it becomes apparent from the current schedule that work will not be completed within the contract time, the Contractor agrees that it will, as necessary, or as directed by the engineer, take action at no additional cost to the County to improve the progress of the work, including increasing manpower, increasing the number of working hours per shift or shifts per working day, increasing the amount of equipment at the site, and any other measure reasonably required to complete the work in a timely fashion.

GC-57 DILIGENCE

The Contractor's failure to substantially comply with the requirements of the preceding paragraph may be grounds for determination by the County or engineer that the Contractor is failing to prosecute the work with such diligence as will ensure its completion within the time specified. In such event, the County shall have the right to furnish such additional labor and materials as may be required to comply with the schedule after 48 hours written notice to the Contractor, and the Contractor shall be liable for such costs incurred by the County.

GC-58 SET-OFFS

Any monies due to the County pursuant to the acceleration provisions of this agreement may be deducted by the County against monies due from the County to the Contractor.

GC-59 ACCELERATION - REMEDIES

The remedies of the County concerning acceleration are in addition to and without prejudice to all of the rights and remedies of the County at law, in equity, or contained in this agreement.

GC-60 TITLE TO MATERIALS

No materials or supplies shall be purchased by the Contractor or by any Subcontractor subject to any chattel mortgage or under a conditional sales contract or other agreement by which any interest is retained by the seller. The Contractor hereby warrants that it has good and marketable title to all materials and supplies used by it in the work, and the Contractor further warrants that all materials and supplies shall be free from all liens, claims, or encumbrances at the time of incorporation in the work.

GC-61 INSPECTION OF MATERIALS

All materials and equipment used in the construction of the project shall be subject to adequate inspection and testing in accordance with accepted standards and in accordance with the requirements of the contract documents. Additional tests performed after the rejection of materials

or equipment shall be at the Contractor's expense.

GC-62 ENGINEER'S PRESENCE DURING TESTING

All tests performed by the Contractor shall be witnessed by the engineer unless the requirement therefor is waived in writing. The engineer may perform additional tests on materials previously tested by the Contractor, and the Contractor shall furnish samples for this purpose as requested.

GC-63 MATERIALS INCORPORATED IN WORK

The Contractor shall furnish all materials and equipment to be incorporated in the work. All such materials or equipment shall be new and of the highest quality available. Manufactured materials and equipment shall be obtained from sources, which are currently manufacturing such materials, except as otherwise specifically approved by the engineer.

GC-64 STORAGE OF MATERIALS

Materials and equipment to be incorporated in the work shall be stored in such a manner as to preserve their quality and fitness for the work and to facilitate inspection.

GC-65 PAYROLL REPORTS

The Contractor shall be required to furnish weekly payroll reports to the engineer certifying conformance with the wage rates listed in the specifications.

GC-66 CONTRACTORS' REPRESENTATIVE

Before beginning work, the Contractor shall notify the engineer in writing of one person within its organization who shall have complete authority to supervise the work, receive orders from the engineer, and represent the Contractor in all matters arising pursuant to this agreement. The Contractor shall not remove its representative without first designating in writing a new representative. The Contractor's representative shall normally be present at or about the site of work while the work is in progress. When neither the Contractor nor its representative is present at the work site, the superintendent, foreman, or other employee in charge of the work shall be an authorized representative of the Contractor.

GC-67 SPECIALTY SUB-CONTRACTORS

The Contractor may utilize the services of specialty subcontractors on those parts of the project which, under normal contracting practices, are performed by specialty subcontractors. Neither the Contractor nor any subcontractor shall award work to any subcontractor without the prior written consent of the County. The Contractor shall not award more than seventy-five percent of the work to subcontractors.

GC-68 INSPECTION BY ENGINEERS

All work pursuant to this agreement shall be subject to inspection by the engineer for conformity with contract drawings and specifications. The Contractor shall give the engineer reasonable advance notice of operations requiring special inspection of a portion of the work.

GC-69 WORK COVERED PRIOR TO ENGINEER'S INSPECTION

In the event that work is covered or completed without the approval of the engineer, and such approval is required by the specifications or required in advance by the engineer, the Contractor shall bear all costs involved in inspection notwithstanding conformance of such portion of the work to the contract drawings and specifications.

GC-70 ENGINEER'S AUTHORITY

The engineer shall have the authority to decide all questions concerning interpretation and fulfillment of contract requirements, including, without limitation, all questions concerning the prosecution, progress, quality and acceptability of the work. Any oral decision or instruction of the engineer shall be confirmed in writing. All communications between the County and the Contractor shall be made through the engineer. The Contractor shall submit to the engineer a complete schedule of values of various portions of the work, including quantities and unit prices, aggregating the contract price. The schedule shall subdivide the work into component parts in sufficient detail to serve as the basis for progress payments during construction. Each item in the schedule of values shall include its proper share of overhead and profit. The schedule of values, when approved by the engineer, shall be used only as a basis for the Contractor's monthly request for payment and shall not be used for additions to or deductions from the contract amount.

GC-71 PROGRESS ESTIMATES

The Contractor shall also prepare a written report for the engineer's approval, on County forms, of the total amount of value of work performed to the date of submission. No progress estimate or payment shall be considered an approval or acceptance of any work performed, and all estimates and payments shall be subject to correction in subsequent estimates. Progress payments shall be made for all completed activities and for suitably stored materials.

GC-72 PROGRESS PAYMENTS

Upon completion of each monthly estimate of work performed and materials furnished, the engineer shall recommend payment to the Contractor for the estimated value of such work, materials, and equipment, less the amount of all prior payments and all liquidated damages. The Contractor will be paid 100 percent, less retainage, of the cost of materials received and properly stored but not incorporated into the work. Payments for materials or equipment stored on the site shall be conditioned upon submission by the Contractor of bills of sale to establish the County's title to such materials or equipment. No progress estimate or payment need be made when, in the engineer's judgment, the increment in the estimated value of work performed and materials furnished since the preceding estimate is less than \$10,000.

GC-73 TIME OF PAYMENT

When the contractor has performed in accordance with the provisions of this Agreement, Gwinnett County shall pay to the contractor, within 30 days of receipt by the County of any payment request based upon work completed or service provided pursuant to the contract, the sum so requested, less the retainage stated in this Agreement, if any. In the event that Gwinnett County fails to pay the contractor within 60 days of the County's receipt of a pay request based upon work completed or service provided pursuant to the contract, the County shall pay the contractor interest at the rate of 1/2 percent per month or pro rata fraction thereof beginning the 61st day following the County's receipt of the pay request. The contractor's acceptance of progress payments or final payment shall release all claims for interest on said payments. The provisions of this agreement are intended to supersede all provisions of the Georgia Prompt Pay Act as provided by law.

GC-74 RETAINAGE

Until the payment for Substantial Completion, the County shall withhold retainage in the amount of five percent (5%) from each progress payment. When Substantial Completion is achieved, retainage shall be paid to Contractor with the final payment in accordance with the terms of Section GC-82.

GC-75 PAYMENT OF SUBCONTRACTORS

GC-75.1 GENERAL

The Contractor shall promptly pay each subcontractor upon the receipt of payment from the County. Such payment shall be made from the amount paid to the Contractor pursuant to the subcontractor's work. The Contractor shall also maintain the records of the percentage retained from payments to

the Contractor pursuant to such subcontractor's work. The Contractor shall procure agreements from each subcontractor requiring each subcontractor to pay their subcontractors, agents and employees in a similar manner.

GC-75.2 SUBCONTRACTOR RETAINAGE RELEASE

Upon request by Contractor, the County may, in its sole discretion, permit an amount equal to the retainage associated with a subcontractor's work to be released from the retainage held by the County upon completion of the subcontractor's work. To request subcontractor retainage release, Contractor shall submit a written request to the County that (a) certifies the subcontractor's work is complete and specifies the amount of retainage withheld by Contractor, (b) contains a release of all claims by the subcontractor, and (c) is executed by the Contractor, subcontractor, and, if required by the County, the engineer.

GC-76 COUNTY'S RESPONSIBILITIES TO SUBCONTRACTORS

Neither the County nor the engineer shall have any obligation to pay any subcontractor except as otherwise required by law.

GC-77 PROGRESS PAYMENTS - ACCEPTANCE OF WORK

Certification of progress payments, as well as the actual payment thereof, shall not constitute the County's acceptance of work performed pursuant to this agreement.

GC-78 PAYMENTS IN TRUST

All sums paid to the Contractor pursuant to this agreement are hereby declared to constitute trust funds in the hands of the contractor to be applied first to the payment of claims of subcontractors, laborers, and suppliers arising out of the work, to claims for utilities furnished and taxes imposed, and to the payment of premiums on surety and other bonds and on insurance for any other application.

GC-79 JOINT PAYMENTS

The County reserves the right to issue any progress payment or final payment by check jointly to the Contractor and any subcontractor or supplier.

GC-80 RIGHT TO WITHHOLD PAYMENT

The engineer may decline to approve payment and may withhold payment in whole or in part to the extent reasonable and necessary to protect the County against loss due to defective work, probable or actual third party claims, the Contractor's failure to pay subcontractors or materialmen, reasonable evidence that the work will not be completed within the contract time or contract price or damage to the County or any other contractor on the project.

GC-81 CERTIFICATE OF SUBSTANTIAL COMPLETION

Upon the Contractor's submission of a request for a certificate of substantial completion, the engineer shall inspect the work and determine whether the work is substantially complete. If the work is substantially complete, the engineer shall issue a certificate of substantial completion of the work which shall establish the date of substantial completion, shall state the responsibilities of the County and the Contractor for security, maintenance, heat, utilities, damage to the work and insurance, and shall fix the time within which the Contractor shall complete the items submitted by the Contractor as requiring correction or further work. The certificate of substantial completion of the work shall be submitted to the County and the Contractor for their written acceptance of the responsibilities assigned to them pursuant to such certificate.

GC-82 FINAL PAYMENT

GC-82.1 GENERAL

Upon Substantial Completion of the work and upon application by the Contractor and approval by the engineer, the County shall make payment reflecting adjustments and retainage for the work as provided in this agreement.

GC-82.2 AMOUNT TO BE WITHHELD

Upon receipt of an application for final payment, the engineer shall designate amounts to be withheld from the payment for incomplete work and/or defective work to be remedied. The amounts withheld shall equal 200 percent of the value of each item of incomplete work and defective work to be remedied. Such amount shall be withheld until completion and remediation of such work.

GC-83 COMMENCEMENT OF WARRANTIES

Warranties required by this agreement shall commence on the date of final completion of the project unless otherwise provided in the certificate of substantial completion.

GC-84 FINAL PAYMENT - WAIVER OF CLAIMS

The acceptance of the substantial completion payment shall constitute a waiver of all claims by the Contractor except those previously made in writing and identified by the Contractor as unsettled at the time of application for payment at substantial completion and except for the retainage sums due at final acceptance. Following the engineer's issuance of the certificate of substantial completion and the Contractor's completion of the work pursuant to this agreement, the Contractor shall forward to the engineer a written notice that the work is ready for final inspection and acceptance and shall also forward to the engineer a final application for payment. When the engineer finds the work acceptable and determines that the contract has been fully performed, the engineer shall issue a certificate for payment which shall approve final payment to the Contractor.

GC-85 DOCUMENTATION OF COMPLETION OF WORK

Neither the final payment nor the remaining retainage shall become due until the Contractor submits the following documents to the engineer:

- A. An affidavit that all payrolls, bills for materials and equipment, and other indebtedness connected with the work have been paid other otherwise satisfied;
- B. The surety's consent to final payment; and
- C. Any other data reasonably required by the County or engineer establishing payment or satisfaction of all such obligations, including releases, waivers of liens, and documents of satisfaction of debts.

In the event that a subcontractor refuses to furnish a release or waiver as required by the County or engineer, the Contractor may furnish a bond satisfactory to the County to indemnify the County against such loss. In the event that any lien or indebtedness remains unsatisfied after all payments are made, the contractor shall refund to the County all moneys that the County may become compelled to pay in discharging such lien or other indebtedness, including all costs and reasonable attorney's fees.

GC-86 GOVERNING LAW

Each and every provision of this agreement shall be construed in accordance with and governed by Georgia law. The parties acknowledge that this contract is executed in Gwinnett County, Georgia and that the contract is to be performed in Gwinnett County, Georgia. Each party hereby consents to the Gwinnett Superior Court's sole jurisdiction over any dispute which arises as a result of the execution or performance of this agreement, and each party hereby waives any and all objections to venue in the Gwinnett Superior Court.

GC-87 CHANGES AND EXTRA WORK

GC-87.1 AUTHORITY FOR CHANGES

The County may make changes in the Drawings or Specifications and in the quantities of Work to be done under the Contract

C-87.2 CHANGE ORDERS

Without invalidating the Contract, the County may at any time or from time to time, by written order, order additions, deletions, or revisions in the Work related to the original scope of the Work. Change Orders will authorize these. Upon receipt of the Change Order, Contractor shall promptly proceed with the work involved. If any price or scope of the Work or an extension or shortening of the Contract Time is involved, an equitable adjustment will be made within the Change Order. In the event the Change Order increases the contract price, the penal amount of the Payment and Performance Bonds shall be increased as provided for in Section GC-15. All changes in the Work authorized by Change Order shall be performed under the applicable Conditions of the Contract Documents.

GC-87.3 WRITTEN NOTICE

The County may, at the request of the Contractor, issue interpretations, clarifications and other instructions as to the intent of the Contract Documents, in the form of Written Notices. The County may also, at any time, make changes in the details of the Work by issuance of a Written Notice. Upon receipt of such a Written Notice containing interpretations, clarifications and other instructions, Contractor shall proceed with the Work and comply with the Written Notice unless Contractor believes that such Written Notice entitles him to a Change in Contract Price or Time or both.

Should Contractor believe that such Written Notice entitles him to change in Contract Price or Time, or both, he shall give the County notice in writing thereof within seven (7) days after receipt of the Written Notice. Thereafter within thirty (30) days, Contractor shall document the basis for the change in Contract Price or Time. The County shall render a timely, written decision on the Contractor's request for a change in Contract Price or Time. Should the County determine that the Contractor is not entitled to a change in Contract Time or Price, the Contractor shall proceed as directed upon receipt of the County's decision. Failure to proceed shall constitute a breach of Contract and shall be a cause for the termination of the Contract. Request for a Change Order arising out of a Written Notice will not be considered without the attachment thereto of a copy of the referenced Written Notice. No claim by Contractor will be allowed if asserted after Final Payment under this Contract.

GC-87.4 EXTRA WORK

Extra work consists of new and unforeseen work determined by the County not to be covered by any of the various items for which there is a bid price or by combination of such items.

GC-87.5 VARIATION IN QUANTITIES

Wherever the estimated quantities of work to be done and materials to be furnished under

this Contract are shown in any of the documents including the Proposal, they are given for use in comparing bids and the right is especially reserved except as herein otherwise specifically limited, to increase or diminish them as may be deemed reasonably necessary or desirable by County to complete the Work contemplated by this Contract, and such increase or diminution shall in no way vitiate this Contract, nor shall any such increase or diminution give cause for claims or liability for damages.

GC-88 CHANGE ORDERS

GC-88.1 GENERAL

The Contract Price may only be changed by a Written Change Order. Each change will be set forth in a Change Order prepared by the County and approved by County. Change Orders will specify (a) all additional work to be done and work to be omitted, if any, in connection with the change; (b) the basis of compensation to the Contractor for additional or omitted work; and (c) any adjustment of the time of completion of the Work. If the County determines that a change requiring additional work will cause delay in completion of Work, he will grant an equitable time extension for the changed work, or a subsequent Change Order may be issued at such time as the extent of such delay can be determined.

Upon receipt of a Change Order, Contractor shall comply therewith and perform each item of work set forth therein, furnishing all labor, material, and equipment necessary therefore, in the same manner as if such work were originally included in the Contract. In the absence of a Change Order, Contractor shall not be entitled to payment or an extension of the time of completion on account of any changes made.

GC-88.2 METHODS OF PAYMENT

The value of any work covered by a Change Order or any claim for an increase or decrease in the Contract Price shall be determined by the following method which is most advantageous to County, as determined by the County:

- A. Where the work involved is covered by unit prices contained in Contract Documents, by application of unit prices to the quantities of the items involved.
- B. By mutual acceptance of a lump sum, based on a detailed breakdown of anticipated costs plus Contractor's fee for overhead, small tools, and profit.
- C. On the basis of the actual cost of the work plus a Contractor's fee for overhead, small tools and profit. This method of payment is herein referred to as force account work. Contractor's fee for force account work performed by his own forces shall be twenty percent (20%) for direct labor and payroll burdens; five percent (5%) for all purchased material; and Contractor's fee for subcontracted work shall be as defined hereinafter.

GC-88.3 LUMP SUM CHANGE ORDER WORK

Contractor shall prepare an estimate of all extra and deleted work as described by Written Notice, using established unit prices where they are stated in the Bidding Documents. Estimates for labor, bonds, insurance, materials, and equipment required shall otherwise be based on the provisions set forth hereinafter.

GC-88.4 CHANGE ORDERS LIMITED

Except as provided herein, no order, statement or conduct of the County or the Construction Program Manager shall be treated as a "Change Order" or entitle the Contractor to any adjustment hereunder of the Contract Price or Contract Time.

GC-88.5 NO WORK STOPPAGE

Nothing in this Article shall excuse the Contractor from proceeding with the Contract as changed.

GC-88.6 CONTRACT AMENDMENT

The amount payable to the Contractor under the Contract, the Contract Time, and the date required for performance of any part of the Work may be changed only by a Change Order to the Contract.

GC-89 FORCE ACCOUNT WORK

Force account work is an Owner-defined emergency, a sudden or unforeseen failure or malfunction of an existing system, which results in the Contractor being obligated to respond to the site of the emergency as Owner-directed. Contractor may perform work on a force account basis and will be paid for properly allocated charges which may include labor, bond premium, supplies and materials, equipment and subcontract billings, incurred in the performance of such force account work as more particularly described below:

- A. Labor: All labor shall be billed at the hourly rates specified in the bid. Regular rates will apply during normal business hours, defined as Monday through Friday, 7a.m.–5p.m. Overtime rates will apply during non-normal business hours. If premium rates apply, then overtime rates shall be defined as Monday through Friday, 5p.m.–8p.m. Accordingly, premium rates, if applicable, shall be defined as Monday through Saturday, 8p.m.–7a.m., all hours on Sundays and all County recognized holidays. A foreman shall not be used where there are fewer than two (2) laborers employed, except with the written consent of the County. Subsistence and travel allowance where required by collective bargaining agreements shall be included.

The charges for labor shall include all classifications through foremen when engaged in the actual and direct performance of the Work. They shall not include charges for such overhead personnel as assistant superintendents, superintendents, office personnel, timekeepers, and maintenance mechanics.

- B. Bonds and Insurance: For bonds and insurance premiums or increases thereto necessitated by the force account work, Contractor shall receive the actual cost to which no percent shall be added. Contractor shall furnish satisfactory evidence of the rate or rates paid for such bond and insurance.
- C. Materials: For materials accepted by the County and used as an integral part of the finished Work, Contractor shall receive the actual cost of such materials delivered on the Work, including transportation charges paid by him, exclusive of machinery rentals as hereinafter set forth.

If materials are procured by Contractor by a method which is not a direct purchase from and a direct billing by the actual supplier, the cost of such materials shall be deemed to be the lowest current wholesale price at which such materials are available in the quantities concerned and delivered to the site of the Work.

For other materials used in the construction which are not an integral part of the finished Work, such as, but not limited to, sheeting, false work and form lumber, Contractor shall be reimbursed in the amount agreed upon by the County before such work is begun. The salvage value of such material will be taken into consideration in determining the amount of reimbursement.

- D. Equipment: Contractor will be paid for the use of Contractor owned or rented equipment at seventy percent (70%) of the suggested monthly rental rates listed for such equipment in the

Blue Book Rental Rates for Construction Equipment (published by Equipment Guide-Book Company of Palo Alto), except as modified below, which edition shall be the latest edition in effect at the time of commencement of the force account work. Hourly rental rates shall be calculated by dividing the listed monthly rates as modified above by 176 hours. The rental rate for equipment used in excess of eight (8) hours per day, shall be at the rate of fifty percent (50%) of the hourly rates as calculated above. The rental rates for standby equipment, when authorized by the County, shall be at the rate of fifty percent (50%) of the hourly rate for equipment in use eight (8) hours per day. No payment of rentals for standby equipment will be made for more than eight (8) hours per working day and no payment will be made for weekend days or holidays. If it is deemed necessary by Contractor to use equipment not listed in the applicable edition of the Blue Book Rental Rates, Contractor shall furnish the necessary cost data and paid invoices to the County for its use in establishment of such rental rate(s). Equipment must be in good operating condition. The rental rates paid as above provided shall include the cost of fuel, oil, lubricants, supplies, small tools, necessary attachments, repairs and maintenance of all kinds, depreciation, storage and insurance. Equipment operators will be paid for as stipulated herein.

The rental time to be paid for equipment on the Work site shall be the time the equipment is required for the force account work being performed. The time shall include the time required to move the equipment to the location of the force account work and return it to the original location or to another location requiring no more time than that required to return it to its original location. Moving time will not be paid if the equipment is used at the site of the force account work on other than such force account work. Loading and transporting costs will be allowed, in lieu of moving time, when the equipment is moved by means other than its own power. No payment for loading and transporting will be made if the equipment is used at the site of the force account work on other than such force account work. Compensation will not be allowed while equipment is inoperative due to breakdown.

For the use of equipment moved in on the work and used exclusively for work paid for on a force account basis, providing the County has agreed to said move, Contractor will be paid the equipment use rates provided for in this clause, for the cost of transporting the equipment to the location of the work and its return to its original location, and for the cost of loading and unloading the equipment, all in accordance with the following provisions:

1. The cost of transporting equipment shall not exceed the applicable minimum established rates by the State of Georgia Public Service commission.
 2. The equipment use period shall begin at the time the equipment is unloaded at the site of the force account work, shall include each day that the equipment is at the site of the force account work, excluding Saturdays and Sundays and other legal holidays unless the force account work is performed on such days, and shall terminate at the end of the day on which the County instructs Contractor to discontinue the use of such equipment. The maximum time to be paid per day will not exceed eight (8) hours unless the equipment is in operation for a longer time.
- E. Subcontract Work: Where the Change Order applies to work being performed under a subcontract, reimbursement, including the fee for small tools, overhead and profit for the subcontractor's work performed on a force account basis shall be computed in precisely the same manner as if performed by Contractor as indicated herein. One additional allowance of five percent (5%) of the subcontractor's total costs will be granted to Contractor for overhead and profit regardless of the tier of the subcontractor. If the subcontractor elects to contract

out change order work to a third (or lower) level contractor or supplier of purchased equipment, he shall not be entitled to fees, overhead or profit for such third (or lower) level work or materials. The County reserves the right to direct the Contractor to contract directly with third (or lower) level subcontractors and suppliers of purchased equipment in order to avoid paying multiple fees, overhead and profit for such third (and lower level) subcontractors and suppliers of purchased equipment. If similar work is not being performed at the Work site, and if required by County, Contractor shall obtain three (3) competitive bids for the requirements of the Change Order and the Contract Documents from Subcontractors acceptable to the County. Selection of the Subcontractor shall be subject to the approval of the County.

- F. Compensation: The compensation as set forth above shall be received by Contractor as payment in full for work done on a force account basis. At the end of each day, Contractor's Representative and Inspector shall compare records of the Work performed including classification of all laborers, ordered on a force account basis.
- G. Statements: No payment will be made for work performed on a force account basis until Contractor furnishes the County itemized statements of the cost of such force account work detailed as to the following:
1. Labor - name, classification, date, daily hours, total hours, rate, and extension of each laborer and foreman.
 2. Equipment - size, type, identification number, dates, daily hours, total hours, rental rate, and extension of each unit of machinery and equipment.
 3. Materials - quantities of supplies and materials, prices, including transportation cost and extensions.
 4. Bonds and insurance premiums.
 5. Subcontract work - force account detail as above, or progress quantities and prices of unit price or lump sum subcontracts.
 6. Payments for items under paragraphs (a) to (f) inclusive shall be conditioned upon Contractor's presentation of original receipted invoices for materials used and transportation charges. If, however, the materials used in the force account work are not specially purchased for such work but are taken from Contractor's stock, then in lieu of the original invoices, the statements shall contain or be accompanied by an affidavit of Contractor which shall certify that such materials were taken from his stock, that the price and transportation of the material as claimed represent actual cost.
- H. If, in the County's opinion, Contractor or any of his subcontractors, in performing force account work, are not making efficient use of labor, material, or equipment and/or are proceeding in a manner which is expensive to the County, the County may request the Contractor to make more efficient use of labor, material and equipment. Contractor shall in good faith comply with such requests as are reasonable. If the Contractor fails to comply with such requests, the County may independently determine the reasonable cost of the work and the Contractor will be entitled only to the reasonable cost so estimated by the County.

GC-90 DISAGREEMENT WITH ORDERS FOR CHANGE

Contractor's written acceptance of a Change Order or other order for changes shall constitute his final and binding agreement to the provisions thereof and a waiver of all claims in connection therewith, whether direct or consequential in nature. Should Contractor disagree with any order for

changes, he may submit a notice of potential claim to the County, at such time as the order is set forth in the form of a Change Order. Disagreement with the provisions of an order for changes shall not relieve Contractor of his obligation under Clause GC-88, Change Orders.

GC-91 CHANGED CONDITIONS

Contractor shall notify the County in writing of the following conditions, hereinafter called "changed conditions," promptly upon their discovery and before they are disturbed:

- A. Subsurface or latent physical conditions at the site of Work differing materially from those represented in this Contract; or
- B. Unknown physical conditions at the Site of the Work of an unusual nature differing materially from those ordinarily encountered and generally recognized as inherent in work of the character provided for in this Contract.

The County will promptly investigate conditions of which it is so notified or conditions discovered by it which appear to be changed conditions, and will, as soon as practicable, issue appropriate orders or instructions. If the County determines that the conditions materially differ and that they will materially increase or decrease the costs of any portion of Work, it will issue a Change Order adjusting the compensation for such portion of Work.

INSURANCE REQUIREMENTS

1. Statutory Workers' Compensation Insurance
 - (a) Employers Liability:
 - ✓ Bodily Injury by Accident - \$100,000 each accident
 - ✓ Bodily Injury by Disease - \$500,000 policy limit
 - ✓ Bodily Injury by Disease - \$100,000 each employee

2. Commercial General Liability Insurance
 - (a) \$500,000 limit of liability per occurrence for bodily injury and property damage
 - (b) The following additional coverage must apply:
 - ✓ 1986 (or later) ISO Commercial General Liability Form
 - ✓ Dedicated Limits per Project Site or Location (CG 25 03 or CG 25 04)
 - ✓ Additional Insured Endorsement (Form B CG 20 10 with a modification for completed operations or a separate endorsement covering Completed Operations)
 - ✓ Blanket Contractual Liability
 - ✓ Broad Form Property Damage
 - ✓ Severability of Interest
 - ✓ Underground, explosion, and collapse coverage
 - ✓ Personal Injury (deleting both contractual and employee exclusions)
 - ✓ Incidental Medical Malpractice
 - ✓ Hostile Fire Pollution Wording

3. Auto Liability Insurance
 - (a) \$500,000 limit of liability per occurrence for bodily injury and property damage
 - (b) Comprehensive form covering all owned, non-owned, leased, hired, and borrowed vehicles
 - (c) Additional Insured Endorsement
 - (d) Contractual Liability

4. Umbrella Liability Insurance - \$1,000,000 limit of liability
 - (a) The following additional coverage must apply
 - ✓ Additional Insured Endorsement
 - ✓ Concurrency of Effective Dates with Primary
 - ✓ Blanket Contractual Liability
 - ✓ Drop Down Feature
 - ✓ Care, Custody, and Control - Follow Form Primary
 - ✓ Aggregates: Apply Where Applicable in Primary
 - ✓ Umbrella Policy must be as broad as the primary policy

5. Gwinnett County Board of Commissioners should be shown as an additional insured on General Liability, Auto Liability and Umbrella Liability policies.

6. The cancellation should provide 10 days notice for nonpayment and 30 days notice of cancellation.

7. Certificate Holder should read:
 - Gwinnett County Board of Commissioners
 - 75 Langley Drive
 - Lawrenceville, GA 30046-6935

8. Insurance Company, except Worker' Compensation carrier, must have an A.M. Best Rating of A-5 or higher. Certain Workers' Comp funds may be acceptable by the approval of the Insurance Unit. European markets including those based in London and domestic surplus lines markets that operate on a non-admitted basis are exempt from this requirement provided that the contractor's broker/agent can provide financial data to establish that a market is equal to or exceeds the financial strengths associated with the A.M. Best's rating of A-5 or better.

9. Insurance Company should be licensed to do business by the Georgia Department of Insurance.
10. Certificates of Insurance, and any subsequent renewals, must reference specific bid/contract by project name and project/bid number.
11. The Contractor shall agree to provide complete certified copies of current insurance policy (ies) or a certified letter from the insurance company (ies) if requested by the County to verify the compliance with these insurance requirements.
12. All insurance coverages required to be provided by the Contractor will be primary over any insurance program carried by the County.
13. Contractor shall incorporate a copy of the insurance requirements as herein provided in each and every subcontract with each and every Subcontractor in any tier, and shall require each and every Subcontractor of any tier to comply with all such requirements. Contractor agrees that if for any reason Subcontractor fails to procure and maintain insurance as required, all such required Insurance shall be procured and maintained by Contractor at Contractor's expense.
14. No Contractor or Subcontractor shall commence any work of any kind under this Contract until all insurance requirements contained in this Contract have been complied with and until evidence of such compliance satisfactory to Gwinnett County as to form and content has been filed with Gwinnett County. **The Acord Certificate of Insurance or a preapproved substitute is the required form in all cases where reference is made to a Certificate of Insurance or an approved substitute.**
15. The Contractor shall agree to waive all rights of subrogation against the County, the Board of Commissioners, its officers, officials, employees, and volunteers from losses arising from work performed by the contractor for the County.
16. Special Form Contractors' Equipment and Contents Insurance covering owned, used, and leased equipment, tools, supplies, and contents required to perform the services called for in the Contract. The coverage must be on a replacement cost basis. The County will be included as a Loss Payee in this coverage for County owned equipment, tools, supplies, and contents.
17. The Contractor shall make available to the County, through its records or records of their insurer, information regarding a specific claim related to any County project. Any loss run information available from the contractor or their insurer relating to a County project will be made available to the County upon their request.
18. Compliance by the Contractor and all subcontractors with the foregoing requirements as to carrying insurance shall not relieve the Contractor and all Subcontractors of their liability provisions of the Contract.
19. The Contractor and all Subcontractors are to comply with the Occupational Safety and Health Act of 1970, Public Law 91-956, and any other laws that may apply to this Contract.
20. The Contractor shall at a minimum apply risk management practices accepted by the contractors' industry.

BONDING AND CONTRACT REQUIREMENTS

General Bond Requirements

1. Bid Bonds - Amount of bond should be 5% of contract amount and submitted with your bid. Gwinnett County form Attached. Failure to use Gwinnett County Bid Bond Form may result in bid being deemed non-responsive and automatic rejection may occur.
2. Performance Bond - (Supplied by successful vendor) - Amount of bond should be 100% of contract amount. **(MUST USE COUNTY FORM)**
3. Payment, Labor and Materials Bonds - (Supplied by successful vendor) - Amount of bond should be 100% of contract amount. **(MUST USE COUNTY FORM)**
4. Bonding company must be authorized to do business by the Georgia Insurance Department.
5. An original/certified copy of the Bonding company's Certificate of Authority or Power of Attorney must be attached to bond. The Certificate of Authority may be obtained from the Georgia Insurance Department.
6. Bonding company must have a minimum AM Best rating of A-V or higher as stated in Insurance Requirements. **Failure to submit a bid bond with the proper rating will result in the bid being deemed non-responsive.**
7. Bonding Company must be listed in the Department of the Treasury's publication of companies holding Certificates of Authority as acceptable surety on Federal Bonds and as acceptable reinsuring companies. (Dept. Circular 570; 1992 Revision).
8. After bid opening, vendor has up to forty-eight (48) hours to notify the Gwinnett County Purchasing Office of an obvious error made in calculation of Bid. Withdrawal of Bid Bond for this reason must be done in writing within the forty-eight (48) hour period. Bid Bond may not be withdrawn otherwise.

Contract Requirements

1. Successful vendor is required to do the following within ten (10) days of notification.
 - A. Return to Purchasing Office contract documents executed by the principal of the company and attested by the secretary or assistant secretary.
 - B. Provide Insurance certificates as specified in the bid documents.
 - C. Provide bonding as required by the bid documents.
2. Failure to execute the Contract, Contract Performance Bond and Payment Bond, or furnish satisfactory proof of carriage of the insurance required within ten days after the date of Notice of Award of the Contract may be just cause for the annulment of the award and for the forfeiture of the bid guaranty to Gwinnett County, not as a penalty, but as liquidation of damages sustained. At the discretion of the County, the award may then be made to the next lowest, responsible bidder, or the work may be re-advertised or constructed by County forces.

The Contract and Contract Bonds shall be executed in duplicate.

*****Gwinnett County requires that all Contracts between parties be entered into via the following documents. If any exceptions are taken to any part of this document, each must be stated in detail and submitted as part of your proposal/bid document. If no exceptions are noted it is assumed that the party fully agrees to the contract in its entirety. Exceptions to the sample contract provided in this request for proposal will be considered in terms of responsiveness when making award.*****

**SAMPLE
CONTRACT**

This **CONTRACT** made and entered into this _____ day of _____, 20____ by and between Gwinnett County, Georgia (Party of the First Part, hereinafter called the County), and _____, (Party of the Second Part, hereinafter called the Contractor).

WITNESSETH: That the said Contractor has agreed, and by these presets does agree with the said County, for the consideration herein mentioned and under the provision of the Performance Bond and Payment Bond required by the Specifications to furnish all equipment, tools, materials, skill and labor of every description necessary to carry out and complete in a good, firm and substantial and workmanlike manner, the work specified, in strict conformity with the drawings and specifications, together with the foregoing proposal made by the Contractor, the Advertisement, the Instructions to Bidders, General Conditions, and this Contract, shall all form essential parts to this Contract. The work covered by this Contract includes all work shown on plans and specifications and listed in the conditions and specifications to wit:

BL076-24, Purchase and Start-up of Submersible Pumps

The Contractor awarded work under this contract shall commence work within ten (10) days after the issuance of the Notice to Proceed and shall fully complete all work hereunder within one hundred and fifty (150) consecutive calendar days from and after said date.

The County shall pay and the Contractor shall receive the prices stipulated in the proposal hereto attached as full compensation for everything furnished and done by the Contractor under this contract, which shall in no event exceed (\$ _____) based on the proposal which sum shall be paid in the manner and terms specified in the Contract Documents, but before issuance of certificate of payment, if the Contractor shall not have submitted evidence satisfactory to the County that all payrolls, materials bills, and other indebtedness connected with the work have been paid, the County may withhold, in addition to the retained percentages, such amount or amounts as may be necessary to pay just claims for labor and services rendered and materials in and about the work, and such amount or amounts withheld or retained may be applied by the County to the payment of such just claims.

When the Contractor has performed in accordance with the provisions of this Contract, Gwinnett County shall pay to the Contractor, within thirty (30) days of receipt of any payment request based upon work completed or service provided pursuant to the Contract, the sum so requested, less the retainage stated in this Contract, if any. In the event that Gwinnett County fails to pay the Contractor within sixty (60) days of receipt of a pay request based upon work completed or service provided pursuant to the Contract, the County shall pay the Contractor interest at the rate of 1/2% per month or pro rata fraction thereof, beginning the sixty-first (61st) day following receipt of the pay request. The Contractor's acceptance of progress payments or final payment shall release all claims for interest on said payments.

PURCHASE AND START-UP OF SUBMERSIBLE PUMPS

BL076-24

It is further mutually agreed between the Parties hereto that if, at any time after the execution of the Contract and the Performance Bond for its faithful performance and the Payment Bond, the first party shall deem the surety or sureties upon such bond to be inadequate to cover the performance of the work, the second party shall, at its expense, within five (5) days after the receipt of notice from the first party to do so, furnish an additional bond or bonds in such form and amount, and with such surety or sureties as shall be satisfactory to the first party. In such event, no further payment to the second party shall be deemed to be due under this Contract until such new or additional security for the faithful performance of the work shall be furnished in a manner and form satisfactory to the first party.

The parties agree that each of the provisions included in this Contract is separate, distinct and severable from the other and remaining provisions of this Contract, and that the invalidity of any Contract provision shall not affect the validity of any other provision or provisions of this Contract.

(Signatures Next Page)

IN WITNESS WHEREOF, the parties hereto, acting through their duly authorized agents, have caused this **CONTRACT** to be signed, sealed and delivered.

GWINNETT COUNTY, GEORGIA

By: _____
Nicole L. Hendrickson, Chairwoman
Gwinnett County Board of Commissioners

ATTEST:

Signature

Diane Kemp, County Clerk
Board of Commissioners

APPROVED AS TO FORM:

Signature
Gwinnett County Staff Attorney

CONTRACTOR: _____

BY: _____
Signature

Print Name

Title

ATTEST:

Signature

Print Name
Corporate Secretary
(Seal)



BL076-24, Purchase and Start-up of Submersible Pumps

**CONTRACTOR AFFIDAVIT AND AGREEMENT
(THIS FORM SHOULD BE FULLY COMPLETED AND RETURNED WITH YOUR SUBMITTAL)**

By executing this affidavit, the undersigned contractor verifies its compliance with The Illegal Immigration Reform Enhancements for 2013, stating affirmatively that the individual, firm, or corporation which is contracting with the Gwinnett County Board of Commissioners has registered with and is participating in a federal work authorization program* [any of the electronic verification of work authorization programs operated by the United States Department of Homeland Security or any equivalent federal work authorization program operated by the United States Department of Homeland Security to verify information of newly hired employees, pursuant to the Immigration Reform and Control Act, in accordance with the applicability provisions and deadlines established therein.

The undersigned further agrees that, should it employ or contract with any subcontractor(s) in connection with the physical performance of services or the performance of labor pursuant to this contract with the Gwinnett County Board of Commissioners, contractor will secure from such subcontractor(s) similar verification of compliance with the Illegal Immigration Reform and Enforcement Act on the Subcontractor Affidavit provided in Rule 300-10-01-.08 or a substantially similar form. Contractor further agrees to maintain records of such compliance and provide a copy of each such verification to the Gwinnett County Board of Commissioners at the time the subcontractor(s) is retained to perform such service.

E-Verify * User Identification Number

Date Registered

Legal Company Name

Street Address

City/State/Zip Code

BY: _____
Authorized Officer or Agent
(Contractor Signature)

Date

Title of Authorized Officer or Agent of Contractor

Printed Name of Authorized Officer or Agent

SUBSCRIBED AND SWORN BEFORE ME ON THIS THE
____ DAY OF _____, 201__

Notary Public
My Commission Expires:_____

For Gwinnett County Use Only:
Document ID # _____
Issue Date: _____
Initials: _____

* As of the effective date of O.C.G.A. 13-10-91, the applicable federal work authorization program is "E-Verify" operated by the U.S. Citizenship and Immigration Services Bureau of the U.S. Department of Homeland Security, in conjunction with the Social Security Administration (SSA).



BL076-24, Purchase and Start-up of Submersible Pumps

CODE OF ETHICS

**(THIS FORM SHOULD BE FULLY COMPLETED AND RETURNED WITH
YOUR SUBMITTAL AND WILL BE REQUIRED PRIOR TO EVALUATION)**

In accordance with Section 54-33 of the Gwinnett County Code of Ordinances the undersigned bidder/proposer makes the following full and complete disclosure under oath, to the best of his/her knowledge, of the name(s) of all elected officials whom it employs or who have a direct or indirect pecuniary interest in or with the bidder/proposer, its affiliates or its subcontractors:

1. _____
(Company Submitting Bid/Proposal)

2. (Please check **one** box below)

No information to disclose *(complete only section 4 below)*

Disclosed information below *(complete section 3 & section 4 below)*

3. (if additional space is required, please attach list)

_____	_____
Gwinnett County Elected Official Name	Gwinnett County Elected Official Name
_____	_____
Gwinnett County Elected Official Name	Gwinnett County Elected Official Name

4.	Sworn to and subscribed before me this
BY: _____	_____ day of _____, 20____
Authorized Officer or Agent Signature	
_____	_____
Printed Name of Authorized Officer or Agent	Notary Public

Title of Authorized Officer or Agent of Contractor	(seal)

Note: See Gwinnett County Code of Ethics Ordinance E02011, Sec. 54-33. The ordinance will be available to view in its' entirety at www.gwinnettcountry.com

BOND # _____

PAYMENT BOND

KNOW ALL MEN BY THESE PRESENTS: that

(Name of Contractor)

(Address of Contractor)

a _____
(Corporation, Partnership or Individual)

hereinafter called Principal, and

(Name of Surety)

(Address of Surety)

a Corporation of the State of _____, and a surety authorized by law to do business in the State of Georgia, hereinafter called Surety, are held and firmly bound unto

Gwinnett County Board of Commissioners
(Name of Obligee)

75 Langley Drive, Lawrenceville, Georgia 30046
(Address of Obligee)

hereinafter called Obligee,

for the use and protection of all subcontractors and all persons supplying labor, services, skill, tools, machinery, materials and/or equipment in the prosecution of the work provided for in the contract hereinafter referred to in the full and just sum of _____

_____ Dollars

(\$ _____) in lawful money of the United States, for the payment of which sum, will and truly to be made, the Principal and Surety bind themselves, their, and each of their heirs, executors, administrators, successors and assigns, jointly and severally, firmly by these presents.

The condition of this obligation is such, as whereas the Principal entered into a certain contract, hereto attached, with the Obligee.

NOW, THEREFORE THE CONDITION OF THIS OBLIGATION IS SUCH, that if the Principal shall well, truly, and faithfully perform said Contract according to its terms, covenants, and conditions, and shall promptly pay all persons furnishing labor, materials services, skill, tools, machinery and/or equipment for use in the performance of said Contract, then this obligation shall be void; otherwise it shall remain in full force and effect.

ALL persons who have furnished labor, materials, services, skill, tools, machinery and/or equipment for use in the performance of said Contract shall have a direct right of action on this Bond, provided payment has not been made in full within ninety (90) days after the last day on which labor was performed, materials, services, skill, tools, machinery, and equipment furnished or the subcontract completed.

PROVIDED FURTHER, that said Surety to this Bond, for value received, hereby stipulates and agrees that no change, extension of time, alterations, or additions to the terms of the Contract or to the Work to be performed thereunder shall in any way affect its obligation on this bond, and it does hereby waive notice of any such change, extension of time, alterations, or additions to the terms of the Contract or to the work to be performed thereunder.

PROVIDED, HOWEVER, that no suit or action shall be commenced hereunder by any person furnishing labor, materials, services, skill, tools, machinery, and/or equipment having a direct contractual relationship with a subcontractor, but no contractual relationship express or implied with the Principal:

Unless such person shall have given notice to the Principal within ninety (90) days after such person did, or performed the last of the work or labor, or furnished the last of the materials, services, skill, tools, machinery and/or equipment for which claim is made, stating with substantial accuracy the amount claimed and the name of the party to whom the materials, services, skill, tools, machinery and/or equipment were furnished, or for whom the work or labor was done or performed. Such a notice shall be served by mailing the same by registered mail, postage prepaid, in an envelope addressed to the Principal, at any place where an office is regularly maintained for the transaction of business, or served in any manner in which legal process may be served in the State in which the aforesaid project is located, save that such service need not be made by a public officer, and a copy of such notice shall be delivered to the Obligee, to the person and at the address provided for in the Contract, within five (5) days of the mailing of the notice to the Principal.

PROVIDED, FURTHER, that any suit under this bond must be instituted before the expiration of one (1) year after the acceptance of the public works covered by the Contract by the proper authorities.

PROVIDED, FURTHER, that Principal and Surety agree and represent that this bond is executed pursuant to and in accordance with the applicable provisions of the Official Code of Georgia Annotated, as Amended, including, but not limited to, O.C.G.A. § 36-91-1 et seq., and is intended to be and shall be construed as a bond in compliance with the requirements thereof.

[Signatures Next Page]

ATTEST:

(Principal Secretary)

(SEAL)

(Witness as to Principal)

(Address)

(Principal)

By:

(Address)

(Surety)

ATTEST:

Resident or Nonresident Agent

(SEAL)

(Witness as to Surety)

(Address)

By: _____
(Attorney-in-Fact)

(Address)

BONDING AGENT CONTACT INFO

Print Name _____

Company Name _____

E-Mail _____

Phone _____

NOTE: If Contractor is Partnership, all partners should execute Bond. Surety Companies executing Bonds must appear on the Treasury Department's most current list (Circular 570 as amended) and be authorized to transact business in the State where the Project is located.

Principal Secretary, Principal and Witness as to Principal signature lines must be signed by three different individuals. Additionally, Resident or Nonresident Agent, Witness as to Surety, and Attorney-in-fact must be signed by three different individuals.

BOND # _____

PERFORMANCE BOND

KNOW ALL MEN BY THESE PRESENTS: that

(Name of Contractor)

(Address of Contractor)

a _____
(Corporation, Partnership or Individual)

hereinafter called Principal, and

(Name of Surety)

(Address of Surety)

a Corporation of the State of _____, and a surety authorized by law to do business in the State of Georgia, hereinafter called Surety, are held and firmly bound unto

Gwinnett County Board of Commissioners

(Name of Obligee)

75 Langley Drive, Lawrenceville, Georgia 30046

(Address of Obligee)

hereinafter referred to as Obligee, are held and firmly bound unto said Obligee and all persons doing work or furnishing skill, tools, machinery, supplies, or material under or for the purpose of the Contract hereinafter referred to, in the penal sum of _____

Dollars (\$ _____) in

lawful money of the United States, for the payment of which sum will and truly to be made, we bind ourselves, our heirs, executors, administrators and successors, jointly and severally, firmly by these presents.

The condition of this obligation is such, as whereas the Principal entered into a certain contract, hereto attached, with the Obligee.

NOW, THEREFORE THE CONDITION OF THIS OBLIGATION IS SUCH, that if the Principal shall well, truly, fully and faithfully perform said contract according to its terms, covenants, conditions, and agreements of said contract during the original term of said contract and any extensions thereof that may be granted by the Obligee, with or without notice to the Surety, and during the life of any guaranty required under the contract, and shall also well and truly perform and fulfill all the undertakings, covenants, terms, conditions and agreement of any and all duly authorized modifications of said contract that may hereafter be made, then this obligation shall be void, otherwise to remain in full force and effect.

PROVIDED FURTHER, that said Surety to this Bond, for value received, hereby stipulates and agrees that no change, extension of time, alterations, or additions to the terms of the Contract or to the Work to be performed thereunder shall in any way affect its obligation on this bond, and it does hereby waive notice of any such change, extension of time, alterations, or additions to the terms of the Contract or to the work to be performed thereunder.

PROVIDED, FURTHER, that Principal and Surety agree and represent that this bond is executed pursuant to and in accordance with the applicable provisions of the Official Code of Georgia Annotated, as Amended, including, but not limited to, O.C.G.A. § 36-91-1 et seq., and is intended to be and shall be construed as a bond in compliance with the requirements thereof.

(Signatures Next Page)

ATTEST:

(Principal Secretary)

(SEAL)

(Witness as to Principal)

(Address)

ATTEST:

Resident or Nonresident Agent

(SEAL)

(Witness as to Surety)

(Address)

(Principal)

By: _____

(Address)

(Surety)

By: _____

(Attorney-in-Fact)

(Address)

BONDING AGENT CONTACT INFO

Print Name _____

Company Name _____

E-Mail _____

Phone _____

NOTE: If Contractor is Partnership, all partners should execute Bond. Surety Companies executing Bonds must appear on the Treasury Department's most current list (Circular 570 as amended) and be authorized to transact business in the State where the Project is located.

Principal Secretary, Principal and Witness as to Principal signature lines must be signed by three different individuals. Additionally, Resident or Nonresident Agent, Witness as to Surety, and Attorney-in-fact must be signed by three different individuals.

FAILURE TO RETURN THIS PAGE MAY RESULT IN REMOVAL OF YOUR COMPANY FROM COMMODITY LISTING.

BL076-24
Buyer Initials: BB

IF YOU DESIRE TO SUBMIT A "NO BID" IN RESPONSE TO THIS PACKAGE, PLEASE INDICATE BY CHECKING ONE OR MORE OF THE REASONS LISTED BELOW AND EXPLAIN.

- Do not offer this product or service; remove us from your bidder's list for this item only.
- Specifications too "tight"; geared toward one brand or manufacturer only.
- Specifications are unclear.
- Unable to meet specifications
- Unable to meet bond requirements
- Unable to meet insurance requirements
- Our schedule would not permit us to perform.
- Insufficient time to respond.
- Other

COMPANY NAME _____

AUTHORIZED REPRESENTATIVE _____
SIGNATURE

*****ATTENTION*****

FAILURE TO RETURN THE FOLLOWING DOCUMENTS MAY RESULT IN BID BEING DEEMED NON-RESPONSIVE AND AUTOMATIC REJECTION:

1. FAILURE TO USE COUNTY BID SCHEDULE.
2. FAILURE TO RETURN APPLICABLE COMPLIANCE SHEETS/SPECIFICATION SHEETS.
3. FAILURE TO RETURN APPLICABLE ADDENDA.
4. FAILURE TO PROVIDE INFORMATION ON ALTERNATES OR EQUIVALENTS.
5. THE COUNTY SHALL BE THE SOLE DETERMINANT OF TECHNICALITY VS. NON-RESPONSIVE BID.
6. FAILURE TO PROVIDE BID BOND, WHEN REQUIRED, WILL RESULT IN BID BEING DEEMED NON-RESPONSIVE AND AUTOMATIC REJECTION. BID BONDS ARE NOT REQUIRED ON ALL BIDS. BOND REQUIREMENTS ARE CLEARLY STATED ON THE INVITATION TO BID. IF YOU NEED CLARIFICATION, CONTACT THE PURCHASING ASSOCIATE. **IF BONDS ARE REQUIRED, FORMS WILL BE PROVIDED IN THIS BID DOCUMENT.**
7. FAILURE TO PROVIDE CONTRACTOR AFFIDAVIT AND AGREEMENT, WHEN REQUIRED, MAY RESULT IN BID BEING DEEMED NON-RESPONSIVE AND AUTOMATIC REJECTION. CONTRACTOR AFFIDAVIT AND AGREEMENT IS NOT REQUIRED ON ALL BIDS. IF YOU NEED CLARIFICATION, CONTACT THE PURCHASING ASSOCIATE.

**GWINNETT COUNTY DEPARTMENT OF FINANCIAL SERVICES – PURCHASING DIVISION
GENERAL INSTRUCTIONS FOR BIDDERS, TERMS AND CONDITIONS**

I. PREPARATION OF BIDS

- A. Each bidder shall examine the drawings, specifications, schedule and all instructions. Failure to do so will be at the bidder's risk, as the bidder will be held accountable for their bid response.
- B. Each bidder shall furnish all information required by the bid form or document. Each bidder shall sign the bid and print or type his or her name on the schedule. The person signing the bid must initial erasures or other changes. An authorized agent of the company must sign bids.
- C. With the exception of solicitations for the sale of real property, individuals, firms and businesses seeking an award of a Gwinnett County contract may not initiate or continue any verbal or written communications regarding a solicitation with any County officer, elected official, employee or other County representative other than the Purchasing Associate named in the solicitation between the date of the issuance of the solicitation and the date of the final contract award by the Board of Commissioners. The Purchasing Director will review violations. If determined that such communication has compromised the competitive process, the offer submitted by the individual, firm or business may be disqualified from consideration for award. Solicitations for the sale of real property may allow for verbal or written communications with the appropriate Gwinnett County representative.
- D. Sample contracts (if pertinent) are attached. These do NOT have to be filled out with the bid/proposal submittal, but are contained for informational purposes only. If awarded, the successful bidder(s) will be required to complete them prior to contract execution.
- E. Effective, July 1, 2013 and in accordance with the Georgia Illegal Immigration Reform Enhancements for 2013, an original signed, notarized and fully completed Contractor Affidavit and Agreement should be included with your bid/proposal submittal, if the solicitation is for the physical performance of services for all labor or service contract(s) that exceed \$2,499.99 (except for services performed by an individual who is licensed pursuant to Title 26, Title 43, or the State Bar of Georgia). Failure to provide the Contractor Affidavit and Agreement with your bid/proposal submittal may result in bid/proposal being deemed non-responsive and automatic rejection.

II. DELIVERY

- A. Each bidder should state time of proposed delivery of goods or services.
- B. Words such as "immediate," "as soon as possible," etc. shall not be used. The known earliest date or the minimum number of calendar days required after receipt of order (delivery A.R.O.) shall be stated (if calendar days are used, include Saturday, Sunday and holidays in the number).

III. EXPLANATION TO BIDDERS

Any explanation desired by a bidder regarding the meaning or interpretation of the invitation for bids, drawings, specifications, etc. must be requested by the question cutoff deadline stated in the solicitation in order for a reply to reach all bidders before the close of bid. Any information given to a prospective bidder concerning an invitation for bid will be furnished to all prospective bidders as an addendum to the invitation if such information is necessary or if the lack of such information would be prejudicial to uninformed bidders. The written bid documents supersede any verbal or written communications between parties. Receipt of addendum should be acknowledged in the bid. **It is the bidder's responsibility to ensure that they have all applicable**

addenda prior to bid submittal. This may be accomplished via contact with the assigned Procurement Agent prior to bid submittal.

IV. SUBMISSION OF BIDS

- A. Bids shall be enclosed in sealed envelopes, addressed to the Gwinnett County Purchasing Office with the name of the bidder, the date and hour of opening and the invitation to bid number on the face of the envelope. Telegraphic/faxed bids will not be considered. Any addenda should be enclosed in the sealed envelopes as well.
- B. ADD/DEDUCT: Add or deduct amounts indicated on the outside of the envelope are allowed and will be applied to the lump sum amount. Amount shall be clearly stated and should be initialed by an authorized company representative.
- C. Samples of items, when required, must be submitted within the time specified and, unless otherwise specified by the County, at no expense to the County. Unless otherwise specified, samples will be returned at the bidder's request and expense if items are not destroyed by testing.
- D. Items offered must meet required specifications and must be of a quality, which will adequately serve the use and purpose for which intended.
- E. Full identification of each item bid upon, including brand name, model, catalog number, etc. must be furnished to identify exactly what the bidder is offering. Manufacturer's literature may be furnished.
- F. The bidder must certify that items to be furnished are new and that the quality has not deteriorated so as to impair its usefulness.
- G. Unsigned bids will not be considered except in cases where bid is enclosed with other documents, which have been signed. The County will determine this.
- H. Gwinnett County is exempt from federal excise tax and Georgia sales tax with regard to goods and services purchased directly by Gwinnett County. Suppliers and contractors are responsible for federal excise tax and sales tax, including taxes for materials incorporated in county construction projects. Suppliers and contractors should contact the State of Georgia Sales Tax Division for additional information.
- I. Information submitted by a bidder in the bidding process shall be subject to disclosure after the public opening in accordance with the Georgia Open Records Act.

V. WITHDRAWAL OF BID DUE TO ERRORS

The bidder shall give notice in writing of his claim of right to withdraw his bid without penalty due to an error within two (2) business days after the conclusion of the bid opening procedure. Bids may be withdrawn from consideration if the price was substantially lower than the other bids due solely to a mistake therein, provided the bid was submitted in good faith, and the mistake was a clerical mistake as opposed to a judgment mistake, and was actually due to an unintentional arithmetic error or an unintentional omission of a quantity of work, labor or material made directly in the compilation of the bid, which unintentional arithmetic error or unintentional omission can be clearly shown by objective evidence drawn from inspection of original work papers, documents and material used in the preparation of the bid sought to be withdrawn. The bidder's original work papers shall be the sole acceptable evidence of error and mistake if he elects to withdraw his bid. If a bid is withdrawn under the authority of this provision, the lowest remaining responsive bid shall be deemed to be low bid.

No bidder who is permitted to withdraw a bid shall, for compensation, supply any material or labor or perform any subcontract or other work agreement for the person or firm to whom the contract is awarded or otherwise benefit, directly or indirectly, from the performance of the project for which the withdrawn bid was submitted.

Supplier has up to forty-eight (48) hours to notify the Gwinnett County Purchasing Office of an obvious clerical error made in calculation of bid in order to withdraw a bid after bid opening. Withdrawal of bid for this reason must be done in writing within the forty-eight (48) hour period. Suppliers who fail to request withdrawal of bid by the required forty-eight (48) hours shall automatically forfeit bid bond. Bid may not be withdrawn otherwise.

Bid withdrawal is not automatically granted and will be allowed solely at Gwinnett County's discretion.

VI. TESTING AND INSPECTION

Since tests may require several days for completion, the County reserves the right to use a portion of any supplies before the results of the tests are determined. Cost of inspections and tests of any item, which fails to meet the specifications, shall be borne by the bidder.

VII. F.O.B. POINT

Unless otherwise stated in the invitation to bid and any resulting contract, or unless qualified by the bidder, items shall be shipped F.O.B. Destination. The seller shall retain title for the risk of transportation, including the filing for loss or damages. The invoice covering the items is not payable until items are delivered and the contract of carriage has been completed. Unless the F.O.B. clause states otherwise, the seller assumes transportation and related charges either by payment or allowance.

VIII. PATENT INDEMNITY

The contractor guarantees to hold the County, its agents, officers or employees harmless from liability of any nature or kind for use of any copyrighted or uncopyrighted composition, secret process, patented or unpatented invention, articles or appliances furnished or used in the performance of the contract, for which the contractor is not the patentee, assignee or licensee.

**IX. BID BONDS AND PAYMENT AND PERFORMANCE BONDS
(IF REQUIRED, FORMS WILL BE PROVIDED IN THIS DOCUMENT)**

A five percent (5%) bid bond, a one hundred percent (100%) performance bond, and a one hundred percent (100%) payment bond must be furnished to Gwinnett County for any bid as required in bid package or document. **Failure to submit a bid bond with the proper rating will result in the bid being deemed non-responsive.** Bonding company must be authorized to do business in Georgia by the Georgia Insurance Commission, listed in the Department of the Treasury's publication of companies holding certificates of authority as acceptable surety on Federal bonds and as acceptable reinsuring companies, and have an A.M. Best rating as stated in the insurance requirement of the solicitation. **The bid bond, payment bond, and performance bond must have the proper an A.M. Best rating as stated in the bid when required in the bid package or document.**

X. DISCOUNTS

- A. Time payment discounts will be considered in arriving at net prices and in award of bids. Offers of discounts for payment within ten (10) days following the end of the month are preferred.
- B. In connection with any discount offered, time will be computed from the date of delivery and acceptance at destination, or from the date correct invoice or voucher is received, whichever is the later date. Payment is deemed to be made for the purpose of earning the discount, on the date of the County check.

XI. AWARD

- A. Award will be made to the lowest responsive and responsible bidder. The quality of the articles to be supplied, their conformity with the specifications, their suitability to the requirements of the County, and the delivery terms will be taken into consideration in making the award. The County may make such investigations as it deems necessary to determine the ability of the bidder to perform, and the bidder shall furnish to the County all such information and data for this purpose as the County may request. The County reserves the right to reject any bid if the evidence submitted by, or investigation of such bidder fails to satisfy the County that such bidder is properly qualified to carry out the obligations of the contract.
- B. The County reserves the right to reject or accept any or all bids and to waive technicalities, informalities and minor irregularities in bids received.
- C. The County reserves the right to make an award as deemed in its best interest, which may include awarding a bid to a single bidder or multiple bidders; or to award the whole bid, only part of the bid, or none of the bid to single or multiple bidders, based on its sole discretion of its best interest.

XII. DELIVERY FAILURES

Failure of a contractor to deliver within the time specified or within reasonable time as interpreted by the Purchasing Director, or failure to make replacement of rejected articles/services when so requested, immediately or as directed by the Purchasing Director, shall constitute authority for the Purchasing Director to purchase in the open market articles/services of comparable grade to replace the articles/services rejected or not delivered. On all such purchases, the contractor shall reimburse the County within a reasonable time specified by the Purchasing Director for any expense incurred in excess of contract prices, or the County shall have the right to deduct such amount from monies owed the defaulting contractor. Alternatively, the County may penalize the contractor one percent (1%) per day for a period of up to ten (10) days for each day that delivery or replacement is late. Should public necessity demand it, the County reserves the right to use or consume articles delivered which are substandard in quality, subject to an adjustment in price to be determined by the Purchasing Director.

XIII. COUNTY FURNISHED PROPERTY

No material, labor or facilities will be furnished by the County unless so provided in the invitation to bid.

XIV. REJECTION AND WITHDRAWAL OF BIDS

Failure to observe any of the instructions or conditions in this invitation to bid may constitute grounds for rejection of bid.

XV. CONTRACT

Each bid is received with the understanding that the acceptance in writing by the County of the offer to furnish any or all of the commodities or services described therein shall constitute a contract between the bidder and the County which shall bind the bidder on his part to furnish and deliver the articles quoted at the prices stated in accordance with the conditions of said accepted bid. The County, on its part, may order from such contractor, except for cause beyond reasonable control, and to pay for, at the agreed prices, all articles specified and delivered.

Upon receipt of a bid package containing a Gwinnett County "Sample Contract" as part of the requirements, it is understood that the bidder has reviewed the documents with the understanding that Gwinnett County requires that all agreements between the parties must be

entered into via this document. If any exceptions are taken to any part, each must be stated in detail and submitted as part of the bid. If no exceptions are stated, it is assumed that the bidder fully agrees to the provisions contained in the "Sample Contract" in its entirety.

Any Consultant as defined in O.C.G.A. §36-80-28 that is engaged to develop or draft specifications/requirements or serve in a consultative role during the procurement process for any County procurement method, , by entering into such an arrangement or executing a contract that the consultant agrees to: (1) Avoid any appearance of impropriety and shall follow all policies and procedures of the County (2) disclose to the County, any material transaction or relationship pursuant to §36-80-28, considered a conflict of interest, any involvement in litigation or other dispute, relationship or financial interest not disclosed in the ethics affidavit, when ethics affidavit is required or such that may be discovered during the pending contract or arrangement; and (3) Acknowledge that any violation or threatened violation of the agreement may cause irreparable injury to the County, entitling the County, to seek injunctive relief in addition to all other legal remedies. This requirement does not apply to confidential economic development activities pursuant to §50-18-72 or to any development authority for the purpose of promoting the development of trade, commerce, industry, and employment opportunities or for other purposes and, without limiting the generality of the foregoing, shall specifically include all authorities created pursuant to Title 36 Chapter 62; However, per provisions of subparagraph (e)(1)(B) of Code Section 36-62-5 reporting of potential conflicts of interest by development authority board members is required.

When the contractor has performed in accordance with the provisions of this agreement, Gwinnett County shall pay to the contractor, within thirty (30) days of receipt of any department approved payment request and based upon work completed or service provided pursuant to the contract, the sum so requested, less the retainage stated in this agreement, if any. In the event that Gwinnett County fails to pay the contractor within sixty (60) days of receipt of a pay requested based upon work completed or service provided pursuant to the contract, the County shall pay the contractor interest at the rate of ½% per month or pro rata fraction thereof, beginning the sixty-first (61st) day following receipt of pay requests. The contractor's acceptance of progress payments or final payment shall release all claims for interest on said payment.

XVI. NON-COLLUSION

Bidder declares that the bid is not made in connection with any other bidder submitting a bid for the same commodity or commodities, and that the bid is bona fide and is in all respects fair and without collusion or fraud. An affidavit of non-collusion shall be executed by each bidder. Collusion and fraud in bid preparation shall be reported to the State of Georgia Attorney General and the United States Justice Department.

XVII. DEFAULT

The contract may be canceled or annulled by the Purchasing Director in whole or in part by written notice of default to the contractor upon non-performance or violation of contract terms. An award may be made to the next low responsive and responsible bidder, or articles specified may be purchased on the open market similar to those so terminated. In either event, the defaulting contractor (or his surety) shall be liable to the County for costs to the County in excess of the defaulted contract prices; provided, however, that the contractor shall continue the performance of this contract to the extent not terminated under the provisions of this clause. Failure of the contractor to deliver materials or services within the time stipulated on his bid, unless extended in writing by the Purchasing Director, shall constitute contract default.

XVIII. TERMINATION FOR CAUSE

The County may terminate this agreement for cause upon ten days prior written notice to the contractor of the contractor's default in the performance of any term of this agreement. Such termination shall be without prejudice to any of the County's rights or remedies by law.

XIX. TERMINATION FOR CONVENIENCE

The County may terminate this agreement for its convenience at any time upon 30 days written notice to the contractor. In the event of the County's termination of this agreement for convenience, the contractor will be paid for those services actually performed. Partially completed performance of the agreement will be compensated based upon a signed statement of completion to be submitted by the contractor, which shall itemize each element of performance.

XX. DISPUTES

Except as otherwise provided in the contract documents, any dispute concerning a question of fact arising under the contract which is not disposed of shall be decided after a hearing by the Purchasing Director, who shall reduce his/her decision to writing and mail or otherwise furnish a copy thereof to the contractor. The decision of the procurement agent shall be final and binding; however, the contractor shall have the right to appeal said decision to a court of competent jurisdiction.

XXI. SUBSTITUTIONS

Bidders offering and quoting on substitutions or who are deviating from the attached specifications shall list such deviations on a separate sheet to be submitted with their bid. The absence of such a substitution list shall indicate that the bidder has taken no exception to the specifications contained herein.

XXII. INELIGIBLE BIDDERS

The County may choose not to accept the bid of a bidder who is in default on the payment of taxes, licenses or other monies due to the County. Failure to respond to three (3) consecutive times for any given commodity/service may result in removal from the supplier list under that commodity/service.

XXIII. OCCUPATION TAX CERTIFICATE

Each successful bidder shall provide evidence of a valid Gwinnett County occupation tax certificate if the bidder maintains an office within the unincorporated area of Gwinnett County. Incorporated, out of County, and out of State bidders are required to provide evidence of a certificate to do business in any town, County or municipality in the State of Georgia, or as otherwise required by County ordinance or resolution.

XXIV. PURCHASING POLICY AND REVIEW COMMITTEE

The Purchasing Policy and Review Committee has been established to review purchasing procedures and make recommendations for changes; resolve problems regarding the purchasing process; make recommendations for standardization of commodities, schedule buying, qualified products list, annual contracts, supplier performance (Ineligible Source List), and other problems or requirements related to Purchasing. The Purchasing Policy & Review Committee has authority to place suppliers and contractors on the Ineligible Source List for reasons listed in Part 6, Section II of the Gwinnett County Purchasing Ordinance.

XXV. AMERICANS WITH DISABILITIES ACT

All contractors for Gwinnett County are required to comply with all applicable sections of the Americans with Disabilities Act (ADA) as an equal opportunity employer. In compliance with the Americans with Disabilities Act (ADA), Gwinnett County provides reasonable accommodations to permit a qualified applicant with a disability to enjoy the privileges of employment equal to those employees with disabilities. Disabled individuals must satisfy job requirements for education background, employment experience, and must be able to perform those tasks that are essential to the job with or without reasonable accommodations. Any requests for the reasonable accommodations required by individuals to fully participate in any open meeting, program or activity of Gwinnett County should be directed to Susan Canon, ADA Coordinator, 75 Langley Drive, Lawrenceville, Georgia 30046, 770-822-8165.

XXVI. ALTERATIONS OF SOLICITATION AND ASSOCIATED DOCUMENTS

Alterations of County documents are strictly prohibited and will result in automatic disqualification of the firm's solicitation response. If there are "exceptions" or comments to any of the solicitation requirements or other language, then the firm may make notes to those areas, but may not materially alter any document language.

XXVII. TAX LIABILITY

Local and state governmental entities must notify contractors of their use tax liability on public works projects. Under Georgia law, private contractors are responsible for paying a use tax equal to the sales tax rate on material and equipment purchased under a governmental exemption that is incorporated into a government construction project: excluding material and equipment provided for the installation, repair, or expansion of a public water, gas or sewer system when the property is installed for general distribution purposes. To the extent the tangible personal property maintains its character (for example the installation of a kitchen stove), it remains tax-exempt. However, if the installation incorporates the tangible personal property into realty, e.g., the installation of sheetrock, it becomes taxable to the private contractor. See O.C.G.A. 48-8-3(2) and O.C.G.A. 48-8-63

XXVIII. STATE LAW REGARDING WORKER VERIFICATION

Effective July 1, 2013 State Law requires that all who enter into a contract for the physical performance of services for all labor or service contract(s) that exceed \$2,499.99 (except for services performed by an individual who is licensed pursuant to Title 26, Title 43, or the State Bar of Georgia) for the County, must satisfy the Illegal Immigration Reform Enhancements for 2013, in all manner, and such are conditions of the contract.

The Purchasing Division Director with the assistance of the Performance Analysis Division shall be authorized to conduct random audits of a contractor's or subcontractors' compliance with the Illegal Immigration Reform Enhancements for 2013 and the rules and regulations of the Georgia Department of Labor. The contractor and subcontractors shall retain all documents and records of its compliance for a period of five (5) years following completion of the contract. This requirement shall apply to all contracts for all labor or service contracts that exceed \$2,499.99 except for services performed by an individual who is licensed pursuant to Title 26, Title 43, or the State Bar of Georgia.

Whenever it appears that a contractor's or subcontractor's records are not sufficient to verify the work eligibility of any individual in the employ of such contractor or subcontractor, the Purchasing Director shall report same to the Department of Homeland Security and may result in termination of the contract if it is determined at any time during the work that the contractor/or subcontractor is no longer in compliance with the Illegal Immigration Reform

Enhancements for 2013.

State Law requires that all who enter into a contract for public works as defined by O.C.G.A. 36-91-2(10) for the County must satisfy the Illegal Immigration Reform Enhancements for 2013, in all manner, and such are conditions of the contract.

By submitting a bid to the County, contractor agrees that, in the event the contractor employs or contracts with any subcontractor(s) in connection with the covered contract, the contractor will secure from the subcontractor(s) such subcontractor(s)' indication of the employee-number category applicable to the subcontractor, as well as attestation(s) from such subcontractor(s) that they are in compliance with the Illegal Immigration Reform Enhancements for 2013. Original signed, notarized Subcontractor Affidavits and Agreements must be submitted to the County.

The Purchasing Division Director with the assistance of the Performance Analysis Division shall be authorized to conduct random audits of a contractor's or subcontractors' compliance with the Illegal Immigration Reform Enhancements for 2013 and the rules and regulations of the Georgia Department of Labor. The contractor and subcontractors shall retain all documents and records of its compliance for a period of three (3) years following completion of the contract. This requirement shall apply to all contracts for the public works as defined by O.C.G.A. 36-91-2(10) where any persons are employed on the County contract.

Whenever it appears that a contractor's or subcontractor's records are not sufficient to verify the work eligibility of any individual in the employ of such contractor or subcontractor, the Purchasing Director shall report same to the Department of Homeland Security.

A contractor's failure to participate in the federal work authorization program as defined by the Illegal Immigration Reform Enhancements for 2013 shall be sanctioned by termination of the contract. If it is determined that a subcontractor is not participating in the federal work authorization program as defined by the Illegal Immigration Reform Enhancements for 2013, Gwinnett County may direct the contractor to terminate that subcontractor. A contractor's failure to follow Gwinnett County's instruction to terminate a subcontractor that is not participating in the federal work authorization program as defined by the Illegal Immigration Reform Enhancements for 2013 may be sanctioned by termination of the contract.

XXIX. SOLID WASTE ORDINANCE

No individual, partnership, corporation or other entity shall engage in solid waste handling except in such a manner as to conform to and comply with the current Gwinnett County Solid Waste Ordinance and all other applicable local, state and federal legislation, rules, regulation and orders.

XXX. GENERAL CONTRACTORS LICENSE

Effective July 1, 2008: All General Contractors must have a current valid license from the State Licensing Board for Residential and General Contractors, unless specifically exempted from holding such license pursuant to Georgia law (O.C.G.A. Section 43-41-17).

XXIX. PRODUCTS MANUFACTURED IN GEORGIA

Gwinnett County, when contracting for or purchasing supplies, materials, equipment, or agricultural products that exceeds \$100,000.00, excluding beverages for immediate consumption, shall give preference as far as may be reasonable and practicable to such supplies, materials, equipment, and agricultural products as may be manufactured or produced

in this state. Such preference shall not sacrifice quality. Gwinnett County Board of Commissioners shall consider, among other factors, information submitted by the bidder which may include the bidder's estimate of the multiplier effect on gross state domestic product and the effect on public revenues of the state and the effect on public revenues of political subdivisions resulting from acceptance of a bid or offer to sell Georgia manufactured or produced goods as opposed to out-of-state manufactured or produced goods. Any such estimates shall be in writing. **(O.C.G.A. Section 36-84-1).**

XXXI. INDEMNIFICATION

To the fullest extent permitted by law, the Contractor shall, at his sole cost and expense, indemnify, defend, satisfy all judgments, and hold harmless the County, the engineer, and their agents and employees from and against all claims, damages, actions, judgments, costs, penalties, liabilities, losses and expenses, including, but not limited to, attorney's fees arising out of or resulting from the performance of the work, provided that any such claim, damage, action, judgment, cost, penalty, liability, loss or expense (1) is attributable to bodily injury, sickness, disease, or death, or to injury to or destruction of tangible property (other than the work itself) including the loss of use resulting therefrom, and (2) is caused in whole or in part by the negligent acts, errors by any act or omission of the Contractor, any subcontractor, anyone directly or indirectly employed by any of them or anyone for whose acts any of them may be liable, regardless whether such claim is caused in part by a party indemnified hereunder. Such obligation shall not be construed to negate, abridge or otherwise reduce any of the rights or obligations of indemnity which would otherwise exist as to any party or person described in this agreement. In any and all claims against the County, the engineer, or any of their agents or employees by any employee of the Contractor, any subcontractor, anyone directly or indirectly employed by any of them, or anyone for whose acts any of them may be liable, the indemnification obligation contained herein shall not be limited in any way by any limitation on the amount or type of damages, compensation, or benefits payable by or for the Contractor or any subcontractor under Worker's Compensation Acts, disability benefit acts, or other employee benefit acts.

XXXII. CODE OF ETHICS:

"Proposer/Bidder" shall disclose under oath the name of all elected officials whom it employs or who have a direct or indirect pecuniary interest in the business entity, its affiliates, or its subcontractors. The "Proposer/Bidder" shall execute a Code of Ethics affidavit. Failure to submit the affidavit during the bid or proposal process shall render the bid or proposal non-responsive.

The act of submitting false information or omitting material information shall be referred to the Purchasing Policy & Review Committee for action pursuant to the Purchasing Ordinance or to the District Attorney for possible criminal prosecution.

Any business entity holding a contract with Gwinnett County that subsequent to execution of the contract or issuance of the purchase order employs, subcontracts with, or transfers a direct or indirect pecuniary interest in the business entity to an elected official shall within five (5) days disclose such fact in writing under oath to the Clerk of the Board of Commissioners. Failure to comply shall be referred to the Purchasing Policy & Review Committee for action pursuant to the Purchasing Ordinance or to the District Attorney for possible criminal prosecution.

Note: See Gwinnett County Code of Ethics Ordinance E02011, Sec. 54-33. The ordinance will be available to view in its entirety at www.gwinnettcountry.com.

XXXIII. PENDING LITIGATION:

A bid submitted by an individual, firm or business who has litigation pending against the County, or anyone representing a firm or business in litigation against the County, not arising out of the procurement process, will be disqualified.

XXXIV. ELECTRONIC PAYMENT

Vendors accepting procurements should select one of Gwinnett County's electronic payment options.

- A. A vendor may select ePayables payment process which allows acceptance of Gwinnett County's virtual credit card as payment for outstanding invoices. The authorized vendor representative must send an email to: vendorelectronicpayment@gwinnettcounty.com and indicate the desire to enroll in Gwinnett County's virtual credit card payment process.
- B. A vendor may select Direct Deposit payment process and the payment will be deposited directly into an account at their designated financial institution. To securely enroll in Direct Deposit, either access your online [Vendor Login and Registration](#) on the County's web site and update the requested information on the Direct Deposit tab or mail a Direct Deposit Authorization Agreement form.

The County will send a Payment Advice notification via email for both payment types.

For more information about Electronic Payments, please go to the Treasury Division page on the County's Web Site or click here -> [Gwinnett County Electronic Payments](#).

DIRECTIONS TO GJAC BUILDING FROM I-85

Take I-85 to Georgia Highway 316 (Lawrenceville/Athens exit). Exit Highway 120 (Lawrenceville/Duluth exit) and turn right. At seventh traffic light, turn right onto Langley Drive. Cross Highway 29 through the traffic light and cross at the 4-way stop sign. The main public parking lot is on the left or behind the building, Click [Here](#), for additional information about parking. The Purchasing Division is located in the Administrative Wing.

CONTRACT DOCUMENTS
FOR
**Gwinnett County Department of
Water Resources**

**Pump Station Pump
Procurement**

GCDWR Project #M-0748
Bid No. BL076-24

**Front End Documents
Volume 1 of 2
April 2024**

Prepared by:

Engineering **S**trategies, **I**nc.
3855 Shallowford Road, Suite 525
Marietta, Georgia 30062 (770)
429-0001

CONTRACT DOCUMENTS
FOR
**Gwinnett County Department of
Water Resources**
**Pump Station Pump
Procurement**

GCDWR Project #M-0748
Bid No. BL076-24

Technical Specifications
Volume 2 of 2
April 2024
Prepared by:

Engineering **S**trategies, **I**nc.
3855 Shallowford Road, Suite 525
Marietta, Georgia 30062 (770)
429-0001

Table of Contents

Division 01 – General Requirements

01 00 00	General Requirements
01 11 00	Summary of Work
01 14 00	Unique Requirements
01 22 15	Measurement and Payment
01 25 00	Substitutions and Product Options
01 33 23	Shop Drawings, Product Data, and Samples
01 42 19	Codes and Standards
01 43 33	Manufacturer Services
01 60 00	General Equipment Stipulations
01 65 00	Transportation and Handling
01 78 23	Operating and Maintenance Data
01 78 33	Warranties and Bonds
01 78 39	Record Documents
01 78 43	Spare Parts
01 91 13	Equipment Testing and Facility Startup

Division 09 – Finishes

09 91 00	Painting
----------	----------

Division 26 – Electrical

26 00 01	General Electrical Provisions
26 00 02	Basic Materials and Methods
26 05 19	Wire and Cable
26 05 26	Grounding
26 05 33.13	Conduit

Division 40 – Process Integration

40 90 01	General Requirements for Instrumentation and Control
40 94 43	Programmable Logic Controller
40 95 16	Instrument and Control Panels

Division 43 – Process Gas and Liquid Handling, Purification, and Storage Equipment

43 21 39	Submersible Pumps
----------	-------------------

Appendices

Appendix A	Sample Pump Station Control Panel Drawings
------------	--

SECTION 01 00 00

GENERAL REQUIREMENTS

PART 1 GENERAL

1.1 SUMMARY

A. Section Includes:

<u>Paragraph</u>	<u>Title</u>
1.2	References
1.3	System Description
1.5	Submittals
3.1	Measures and Weights
3.2	Mill and Shop Tests and Inspections
3.3	Painting and Coatings
3.4	Record Drawings
3.5	Safety
3.6	Sales Tax

1.2 REFERENCES

- A. Unless otherwise specified, references to documents shall mean the documents in effect at the time of Advertisement for Bids or Invitation to Bid (or on the effective date of the Agreement if there were no bids). If referenced documents have been discontinued by the issuing organization, references to those documents shall mean the replacement documents issued or otherwise identified by that organization or, if there are no replacement documents, the last version of the documents before it was discontinued shall apply.
- B. These Specifications contain references to the entities identified in Section 01 42 19 – Codes and Standards. They are a part of these Specifications as specified and modified. Where a referenced document contains references to other standards, those documents are included as references under this section as if referenced directly. In the event of conflict between the requirements of this section and those of the listed documents, the requirements of this section shall prevail.

1.3 SYSTEM DESCRIPTION

A. Performance Requirements

1. The Work shall be comprised of and for the construction of the Owner's infrastructure as identified in the Bid Schedule, including but not limited to, safety, testing, and fabrication with any and all appurtenances in accordance with the Contract Documents, complete and fully operational in compliance with federal, state, county, and local codes and regulations, standards, and specifications as applicable at the time of bid unless otherwise directed in writing by the Owner.

1.4 SUBMITTALS

- A. Submittals specified for submission shall be by the Supplier only to Owner or its Engineer as specified.

- B. Each submittal, with variations from the requirements of the Contract Documents, shall make specific mention of such variations. Those declared variations found acceptable by Engineer and Owner shall require the Contractor to take suitable action for the proper installation in accordance with the Contract Documents. Variation not declared or suitable action not taken by the Contractor shall not relieve him/her of the responsibility for executing the Work or error and cost for remedial actions deemed necessary by the Owner.

PART 2 PRODUCTS – (NOT USED)

PART 3 EXECUTION

3.1 MEASURES AND WEIGHTS

- A. Whenever so requested as deemed necessary by the Owner, provide accurate scales, adequate equipment, and the necessary assistance for weighing and/or measuring materials for the installed Work as specified.
- B. It is understood and agreed that a “ton” shall mean the short ton of two thousand (2,000) pounds.

3.2 MILL AND SHOP TESTS AND INSPECTIONS

- A. Where the specifications call for mill or shop tests, furnish triplicate copies of attested certificates signed by a duly authorized representative of the manufacturer, showing details of quality or performance sufficient to demonstrate compliance with the Contract Documents.
- B. Make inspection of materials as required by these Specifications.

3.3 PAINTING AND COATINGS

- A. It is the intention of these Specifications that metal permanently installed in the Work shall be protected by a durable coating of paint, or other approved material as specified in Division 9 of these Specifications.
- B. It is the intention of these Specifications that concrete or metal surface in corrosive environments shall be protected by a durable coating as specified in Division 9 of these Specifications.

3.4 RECORD DRAWINGS

- A. Prepare, maintain, and furnish accurate as-built drawings for the purpose of providing record drawings of the control panel in accordance with Section 01 78 39 – Record Documents.

3.5 SAFETY

- A. Unless otherwise specified comply with and maintain all federal, state, county, and local regulations during the course of the Work.

3.6 SALES TAX

- A. Furnish the Owner with certified copies of paid invoices or their equivalent proof covering sales tax paid on items which the Owner is eligible for tax refund; none of which shall be refunded or credited to the Contractor.

END OF SECTION

SECTION 01 11 00

SUMMARY OF WORK

PART 1 GENERAL

1.1 SUMMARY

A. Section Includes:

<u>Paragraph</u>	<u>Title</u>
1.2	Work Covered by Contract Documents
1.3	Project Location
1.4	Quantities
1.5	Communications

1.2 WORK COVERED BY CONTRACT DOCUMENTS

A. The Work to be performed under this Contract shall consist of furnishing submersible pumps and control panels, and providing start-up services after installation at multiple wastewater pump stations as identified below.

B. The Work can generally be described as consisting of:

1. Provide shop drawings and submittals for new pumps and control panel.
2. Furnish new pumps and accessories in accordance with these specifications
3. Furnish new control panel in accordance with these specifications and the example panel drawings.
4. Provide start-up and training services following installation of the pumps. Pumps will be installed by Owner or their Contractor, who will coordinate with the pump manufacturer for the start-up services.
5. Address warranty issues related to the pumps and control panel

C. Related Requirements

1. Prepare and submit all required shop drawings of equipment and structural items to be furnished.
2. Label all electrical and control wiring on both ends
3. Perform all warranty work.

D. Perform all work as shown on the Drawings and as specified.

1.3 PROJECT LOCATION

A. The equipment and materials to be furnished will be installed at the locations indicated. The project sites are located in Gwinnett County, Georgia at the following locations.

1. 2000 West Place PS – 4791 Score Court, Snellville, GA 30039
2. Centerville Road PS – 3495 Hwy. 124, Snellville, GA 30039
3. Millerbrook PS – 310 Lee Miller Court, Suwanee, GA 30024
4. Mink Livsey PS – 4753 Bryant Drive, Snellville, GA 30039
5. Northbrook #2 (North) PS – 941 Northbrook Pkwy, Lawrenceville, GA 30043
6. Roselake PS – 3453 Kenilworth Court, Snellville, GA 30039

7. Southfork PS – 3592 Prairie Drive, Snellville, GA 30039

1.4 QUANTITIES

- A. The Owner reserves the right to alter the quantities of work to be performed or to extend or shorten the improvements at any time when and as found necessary, and the supplier shall furnish the work as altered, increased or decreased. Payment for such increased or decreased quantity will be made in accordance with the Instructions to Bidders. No allowance will be made for any change in anticipated profits nor shall such changes be considered as waiving or invalidating any conditions or provisions of the Contract and Bond.

1.5 COMMUNICATIONS

- A. Submit all communications in writing. Use prescribed forms as required by the Owner.
- B. Designate in writing the individuals who will be the Contractor's authorized representatives.

END OF SECTION

SECTION 01 14 00

UNIQUE REQUIREMENTS

PART 1 GENERAL

1.1 SUMMARY

A. Section Includes

<u>Paragraph</u>	<u>Title</u>
1.2	Milestone Dates
1.3	Submittals

B. Scope

1. The scope of this Section is to convey to the Supplier unique and unusual stipulations and requirements which have been established for this Project. Requirements are based on technical and scheduling aspects of the Project. The provisions of this Section shall supersede the provisions of the Division 01 through 44 Specifications but shall not supersede the Bidding Requirements, Contract Forms or Conditions of the Contract.

1.2 MILESTONE DATES

A. Complete the following activities by the indicated date or days after the Notice to Proceed:

Consecutive Calendar Days	Milestone	Liquidated Damages Per Calendar Day
28 days after Issuance of Purchase Order	Submittal of Shop Drawings	\$500.00
150 days after return of approved submittals	Delivery of pumps, accessories, and control panel	\$500.00

- B. For the purposes of assessing liquidated damages, Submittal of Shop Drawings shall be defined as the time at which the Engineer has received all required submittals for the pumps, accessories, and control panels for each pump station awarded to the supplier
- C. Delivery of pumps, accessories, and control panel shall be defined as the time when all equipment and materials have been delivered by the supplier to the Owner's Central Facility at 684 Winder Hwy., Lawrenceville, GA 30045, or other designated location.

1.3 SUBMITTALS

A. Sequence Submittal

1. Submit a proposed sequence in accordance with Section 01 32 16 with appropriate times of starting and completion of tasks to Engineer for review.
2. The Contractor may propose alternatives to the sequencing constraints to that shown in this Section in an attempt to reduce the disruption of the operation of the existing facility or streamline the tasks of this Contract. The Owner and Engineer are not obligated to accept any of these alternatives.

END OF SECTION

SECTION 01 22 15

MEASUREMENT AND PAYMENT

PART 1 GENERAL

1.1 SUMMARY

A. Section Includes

<u>Paragraph</u>	<u>Title</u>
1.2	Descriptions
1.3	Nonpayment for Rejected or Unused Products
1.4	Partial Payment for Stored Materials and Equipment
1.5	Bid Items

B. Scope

1. The Bid lists each item of the Project for which payment will be made. No payment will be made for any items other than those listed in the Bid.
2. Required items of work and incidentals necessary for the satisfactory completion of the work which are not specifically listed in the Bid, and which are not specified in this Section to be measured or to be included in one of the items listed in the Bid, shall be considered as incidental to the work. All costs thereof, including Contractor's overhead costs and profit, shall be considered as included in the lump sum or unit prices bid for the various Bid items. The Contractor shall prepare the Bid accordingly.
3. Work includes furnishing all plant, labor, equipment, tools and materials, which are not furnished by the Owner and performing all operations required to complete the Work satisfactorily, in place, as specified and as indicated on the Drawings.

1.2 DESCRIPTIONS

- A. Measurement of an item of work will be by the unit indicated in the Bid.
- B. Payment will include all necessary and incidental related work not specified to be included in any other item of work listed in the Bid.
- C. Unless otherwise stated in individual sections of the Specifications or in the Bid, no separate payment will be made for any item of work, materials, parts, equipment, supplies or related items required to perform and complete the work. The costs for all such items required shall be included in the price bid for item of which it is a part.
- D. Payment will be made by extending unit prices multiplied by quantities provided and then summing the extended prices to reflect actual work. Such price and payment shall constitute full compensation to the Contractor for furnishing all plant, labor, equipment, tools and materials not furnished by the Owner and for performing all operations required to provide to the Owner the entire Project, complete in place, as specified and as indicated on the Drawings.

1.3 NONPAYMENT FOR REJECTED OR UNUSED PRODUCTS

- A. Payment will not be made for the following:
 1. Loading, hauling, and disposing of rejected material.
 2. Rejected loads of material.

3. Material not unloaded from transporting vehicle.

1.4 PARTIAL PAYMENT OF STORED MATERIALS AND EQUIPMENT

- A. Partial Payment: No partial payments will be made for materials and equipment delivered or stored unless Shop Drawings and operation and maintenance manuals are acceptable to Engineer.
- B. Final Payment: Will be made upon successful start-up of the pumps and control panel for the respective pump station.

1.5 BID ITEMS

- A. Bid Prices included on the Bid Form shall be full compensation for all materials, labor, equipment, tools, construction equipment and machinery, heat, utilities, transportation, taxes, overhead, markup, incidentals and services necessary for the execution and completion of the Work in the Contract Documents to be performed under this Contract. For the Work described, the allowance and unit price, actual used and installed quantities of each bid item shall be measured in the field and certified by the Engineer and/or Owner upon completion of construction in the manner set forth for each item in this and other sections of the Specifications. Payment for all items listed on the Bid Form will constitute full compensation for all Work shown and specified to be performed.

- B. The following items 1 through 7 comprise the Base Bid Total as listed on the Bid Form.

1. **2000 WEST PLACE PS:**

- a. MEASUREMENT: Measurement shall be based on the successful furnishing and starting up the pumps and control panel for the 2000 West Place PS.
- b. PAYMENT: Supplier shall furnish, check-out and provide start-up services for the new submersible pumps and control panel for the pump station. Payment will be made for the items as identified in the Bid Schedule, as follows:
 - 1) Submittals: Supplier shall furnish submittals for all required items including the pumps, control panel, and required accessories. Payment will not be approved for submittals until submittals for all items are approved.
 - 2) Pumps and Control Panel: Supplier shall furnish factory test curves for approval and deliver the new pumps and control panel to the location designated by GCDWR following approval of the test curves. Payment will not be made until the pumps and control panel have been delivered and accepted by GCDWR.
 - 3) Pump Accessories: Supplier shall furnish the required pump accessories, spare parts, and Operation and Maintenance Manuals as identified in the specifications. Payment will not be made until all required accessories, spare parts, and Operation and Maintenance Manuals have been delivered and accepted by GCDWR.
 - 4) Start-up, Testing, and Training Services: Following installation of the pumps and control panel by others, Supplier shall inspect and certify proper installation, perform start-up of the pumps and control panel, test the equipment for proper operation and that it is meeting the required duty point, and provide training services to GCDWR personnel. Payment will not be made until the pumps and control panel are operating as required, as determined by the Engineer, all start-up documentation and certifications are submitted, and training is complete.

2. **CENTERVILLE ROAD PS PUMPS AND CONTROL PANEL:**

- a. MEASUREMENT: Measurement shall be based on the successful furnishing and starting up the pumps and control panel for the Centerville Road PS.
- b. PAYMENT: Supplier shall furnish, check-out and provide start-up services for the new submersible pumps and control panel for the pump station. Payment will be made for the items as identified in the Bid Schedule, as follows:
 - 1) Submittals: Supplier shall furnish submittals for all required items including the pumps, control panel, and required accessories. Payment will not be approved for submittals until submittals for all items are approved.
 - 2) Pumps and Control Panel: Supplier shall furnish factory test curves for approval and deliver the new pumps and control panel to the location designated by GCDWR following approval of the test curves. Payment will not be made until the pumps and control panel have been delivered and accepted by GCDWR.
 - 3) Pump Accessories: Supplier shall furnish the required pump accessories, spare parts, and Operation and Maintenance Manuals as identified in the specifications. Payment will not be made until all required accessories, spare parts, and Operation and Maintenance Manuals have been delivered and accepted by GCDWR.
 - 4) Start-up, Testing, and Training Services: Following installation of the pumps and control panel by others, Supplier shall inspect and certify proper installation, perform start-up of the pumps and control panel, test the equipment for proper operation and that it is meeting the required duty point, and provide training services to GCDWR personnel. Payment will not be made until the pumps and control panel are operating as required, as determined by the Engineer, all start-up documentation and certifications are submitted, and training is complete.

3. MILLERBROOK PS PUMPS AND CONTROL PANEL:

- a. MEASUREMENT: Measurement shall be based on the successful furnishing and starting up the pumps and control panel for the Millerbrook PS.
- b. PAYMENT: Supplier shall furnish, check-out and provide start-up services for the new submersible pumps and control panel for the pump station. Payment will be made for the items as identified in the Bid Schedule, as follows:
 - 1) Submittals: Supplier shall furnish submittals for all required items including the pumps, control panel, and required accessories. Payment will not be approved for submittals until submittals for all items are approved.
 - 2) Pumps and Control Panel: Supplier shall furnish factory test curves for approval and deliver the new pumps and control panel to the location designated by GCDWR following approval of the test curves. Payment will not be made until the pumps and control panel have been delivered and accepted by GCDWR.
 - 3) Pump Accessories: Supplier shall furnish the required pump accessories, spare parts, and Operation and Maintenance Manuals as identified in the specifications. Payment will not be made until all required accessories, spare parts, and Operation and Maintenance Manuals have been delivered and accepted by GCDWR.
 - 4) Start-up, Testing, and Training Services: Following installation of the pumps and control panel by others, Supplier shall inspect and certify proper installation, perform start-up of the pumps and control panel, test the equipment for proper operation and that it is meeting the required duty point,

and provide training services to GCDWR personnel. Payment will not be made until the pumps and control panel are operating as required, as determined by the Engineer, all start-up documentation and certifications are submitted, and training is complete.

4. MINK LIVSEY PS PUMPS AND CONTROL PANEL:

- a. MEASUREMENT: Measurement shall be based on the successful furnishing and starting up the pumps and control panel for the Mink Livsey PS.
- b. PAYMENT: Supplier shall furnish, check-out and provide start-up services for the new submersible pumps and control panel for the pump station. Payment will be made for the items as identified in the Bid Schedule, as follows:
 - 1) Submittals: Supplier shall furnish submittals for all required items including the pumps, control panel, and required accessories. Payment will not be approved for submittals until submittals for all items are approved.
 - 2) Pumps and Control Panel: Supplier shall furnish factory test curves for approval and deliver the new pumps and control panel to the location designated by GCDWR following approval of the test curves. Payment will not be made until the pumps and control panel have been delivered and accepted by GCDWR.
 - 3) Pump Accessories: Supplier shall furnish the required pump accessories, spare parts, and Operation and Maintenance Manuals as identified in the specifications. Payment will not be made until all required accessories, spare parts, and Operation and Maintenance Manuals have been delivered and accepted by GCDWR.
 - 4) Start-up, Testing, and Training Services: Following installation of the pumps and control panel by others, Supplier shall inspect and certify proper installation, perform start-up of the pumps and control panel, test the equipment for proper operation and that it is meeting the required duty point, and provide training services to GCDWR personnel. Payment will not be made until the pumps and control panel are operating as required, as determined by the Engineer, all start-up documentation and certifications are submitted, and training is complete.

5. NORTHBROOK #2 PS PUMPS AND CONTROL PANEL:

- a. MEASUREMENT: Measurement shall be based on the successful furnishing and starting up the pumps and control panel for the Northbrook #2 PS.
- b. PAYMENT: Supplier shall furnish, check-out and provide start-up services for the new submersible pumps and control panel for the pump station. Payment will be made for the items as identified in the Bid Schedule, as follows:
 - 1) Submittals: Supplier shall furnish submittals for all required items including the pumps, control panel, and required accessories. Payment will not be approved for submittals until submittals for all items are approved.
 - 2) Pumps and Control Panel: Supplier shall furnish factory test curves for approval and deliver the new pumps and control panel to the location designated by GCDWR following approval of the test curves. Payment will not be made until the pumps and control panel have been delivered and accepted by GCDWR.
 - 3) Pump Accessories: Supplier shall furnish the required pump accessories, spare parts, and Operation and Maintenance Manuals as identified in the specifications. Payment will not be made until all required accessories, spare

parts, and Operation and Maintenance Manuals have been delivered and accepted by GCDWR.

- 4) Start-up, Testing, and Training Services: Following installation of the pumps and control panel by others, Supplier shall inspect and certify proper installation, perform start-up of the pumps and control panel, test the equipment for proper operation and that it is meeting the required duty point, and provide training services to GCDWR personnel. Payment will not be made until the pumps and control panel are operating as required, as determined by the Engineer, all start-up documentation and certifications are submitted, and training is complete.

6. ROSELAKE PS PUMPS AND CONTROL PANEL:

- a. MEASUREMENT: Measurement shall be based on the successful furnishing and starting up the pumps and control panel for the Roselake PS.
- b. PAYMENT: Supplier shall furnish, check-out and provide start-up services for the new submersible pumps and control panel for the pump station. Payment will be made for the items as identified in the Bid Schedule, as follows:
 - 1) Submittals: Supplier shall furnish submittals for all required items including the pumps, control panel, and required accessories. Payment will not be approved for submittals until submittals for all items are approved.
 - 2) Pumps and Control Panel: Supplier shall furnish factory test curves for approval and deliver the new pumps and control panel to the location designated by GCDWR following approval of the test curves. Payment will not be made until the pumps and control panel have been delivered and accepted by GCDWR.
 - 3) Pump Accessories: Supplier shall furnish the required pump accessories, spare parts, and Operation and Maintenance Manuals as identified in the specifications. Payment will not be made until all required accessories, spare parts, and Operation and Maintenance Manuals have been delivered and accepted by GCDWR.
 - 4) Start-up, Testing, and Training Services: Following installation of the pumps and control panel by others, Supplier shall inspect and certify proper installation, perform start-up of the pumps and control panel, test the equipment for proper operation and that it is meeting the required duty point, and provide training services to GCDWR personnel. Payment will not be made until the pumps and control panel are operating as required, as determined by the Engineer, all start-up documentation and certifications are submitted, and training is complete.

7. SOUTHFORK PS PUMPS AND CONTROL PANEL:

- a. MEASUREMENT: Measurement shall be based on the successful furnishing and starting up the pumps and control panel for the Southfork PS.
- b. PAYMENT: Supplier shall furnish, check-out and provide start-up services for the new submersible pumps and control panel for the pump station. Payment will be made for the items as identified in the Bid Schedule, as follows:
 - 1) Submittals: Supplier shall furnish submittals for all required items including the pumps, control panel, and required accessories. Payment will not be approved for submittals until submittals for all items are approved.
 - 2) Pumps and Control Panel: Supplier shall furnish factory test curves for approval and deliver the new pumps and control panel to the location

designated by GCDWR following approval of the test curves. Payment will not be made until the pumps and control panel have been delivered and accepted by GCDWR.

- 3) Pump Accessories: Supplier shall furnish the required pump accessories, spare parts, and Operation and Maintenance Manuals as identified in the specifications. Payment will not be made until all required accessories, spare parts, and Operation and Maintenance Manuals have been delivered and accepted by GCDWR.
- 4) Start-up, Testing, and Training Services: Following installation of the pumps and control panel by others, Supplier shall inspect and certify proper installation, perform start-up of the pumps and control panel, test the equipment for proper operation and that it is meeting the required duty point, and provide training services to GCDWR personnel. Payment will not be made until the pumps and control panel are operating as required, as determined by the Engineer, all start-up documentation and certifications are submitted, and training is complete.

PART 2 PRODUCTS (NOT USED)

PART 3 EXECUTION (NOT USED)

END OF SECTION

SUBSTITUTIONS AND PRODUCT OPTIONS

PART 1 GENERAL

1.1 SUMMARY

A. Section Includes

<u>Paragraph</u>	<u>Title</u>
1.2	Definitions
1.3	General
1.4	Approvals
1.5	Substitution and Product Options

B. Scope

1. This Section outlines the restrictions and requirements for substitutions, product and manufacturer options, and fabrication method options.

1.2 DEFINITIONS

A. For the purposes of these Contract Documents, a “substitute item” shall include “or-equal items” and shall be defined as one of the following:

1. A product or manufacturer offered as a replacement to a specified product or manufacturer.
2. A product or manufacturer offered in addition to a specified product or manufacturer.

1.3 GENERAL

- A. An item or fabrication method, which is offered where no specific product, manufacturer, mean, method, technique, sequence or procedure of construction is specified or shown on the Drawings, shall not be considered a substitute and shall be at the option of the Supplier, subject to the provisions in the Contract Documents for that item or fabrication method.
- B. For products specified only by a referenced standard, the Supplier may select any product by any manufacturer, which meets the requirements of the Specifications, unless indicated otherwise in the Contract Documents.
- C. If the manufacturer is named in the Specifications as an acceptable manufacturer, products of that manufacturer meeting all requirements of the Specifications and Drawings are acceptable.
- D. Whenever the design is based on a specific product of a particular manufacturer, that manufacturer will be listed first in the list of approved manufacturers in the Specifications. Any Bidder intending to furnish products from other than the first listed manufacturer, or furnish substitute items, shall:
 1. Verify that the item being furnished will fit in the space allowed, perform the same functions and have the same capabilities as the item specified,
 2. Include in its Bid the cost of all accessory items which may be required by the other listed substitute product,
- E. Whenever a product specification includes minimum experience requirements which the manufacturer selected by the Supplier cannot meet, the manufacturer shall furnish the

Owner with a cash deposit, or bond acceptable to the Owner in an amount equal to the cost of the product, which shall remain in effect until the experience requirement has been met.

1.4 APPROVALS

- A. Approval, of a substitution as an acceptable manufacturer, of the Engineer is dependent on determination that the product offered:
 - 1. is essentially equal in function, performance, quality of manufacture, ease of maintenance, reliability, service life and other criteria to that on which the design is based, and
 - 2. will require no major modifications to structures, electrical systems, control systems, or piping systems.

1.5 SUBSTITUTION AND PRODUCT OPTIONS

- A. No changes will be considered for the major products or systems selected in the Bid.
- B. Substitute items will be considered only if the term “equal to” precedes the names of acceptable manufacturers in the Specification.
- C. After Notice to Proceed:
 - 1. Where items are specified by referenced standard or specified as indicated above in Article 1.3, Paragraph A, such items shall be submitted to the Engineer for review.
 - 2. The Contractor shall submit shop drawings on the substitute item for the Engineer's review in accordance with the Section 01 33 23.
- D. Prior to Opening of Bids
 - 1. No consideration or approvals will be made for products specified by a referenced standard, or specified as indicated in Article 1.3, Paragraph A above. Such consideration may occur only after the Notice to Proceed.
 - 2. No consideration or approvals will be made for products being offered where the term “equal to” precedes the name of an approved product. Such substitution consideration may occur only after the Notice to Proceed.

PART 2 PRODUCTS (NOT USED)

PART 3 EXECUTION (NOT USED)

END OF SECTION

SECTION 01 33 23

SHOP DRAWINGS, PRODUCT DATA, AND SAMPLES

PART 1 GENERAL

1.1 SUMMARY

A. Section Includes

<u>Paragraph</u>	<u>Title</u>
1.2	Specific Category Requirements
1.3	Routing of Submittals
1.4	Submittal Log
2.1	Shop Drawings
2.2	Manufacturer's Literature
2.4	Administrative Submittals
2.5	Quality Control Submittals
2.6	Contract Closeout Submittals
3.1	Supplier's Coordination of Submittals
3.2	Timing of Submittals
3.3	Reviewed Submittals
3.4	Resubmission Requirements

B. Scope

1. The work under this Section includes submittal to the Engineer of shop drawings, product data and samples required by the various Sections of these Specifications.
2. Submittal Contents: The submittal contents required are specified in each Section.
3. Definitions: Submittals are categorized as follows:
 - a. Shop Drawings:
 - 1) Shop drawings shall include technical data, drawings, diagrams, procedures and methodology, performance curves, schedules, templates, patterns, test reports, calculations, instructions, measurements and similar information as applicable to the specific item for which the shop drawing is prepared.
 - 2) Provide newly-prepared information, in searchable PDF format with graphic information at accurate scale (except as otherwise indicated), with name of preparer (firm name) indicated. Show dimensions and note dimensions that are based on field measurement. Identify materials and products in the work shown. Indicate compliance with standards and special coordination requirements. Do not allow shop drawings to be used in connection with the Work without appropriate final "Action" markings by the Engineer.
 - 3) Present drawings in a clear and thorough manner. Identify details by reference to sheet and detail, Specification Section, schedule or room numbers shown on the Contract Drawings.
 - 4) Minimum assembly drawings sheet size: 11-inches by 17-inches.
 - 5) Minimum detail sheet size: 8-1/2-inches by 11-inches.

- 6) Minimum Scale: $\frac{1}{4}$ -inch = 1 foot.
 - b. Product Data:
 - 1) Product data includes standard printed information on materials, products and systems, not specially prepared for this Project, other than the designation of selections from among available choices printed therein.
 - 2) Collect required data into one submittal for each unit of work or system, and mark each copy to show which choices and options are applicable to the Project. Include manufacturer's standard printed recommendations for application and use, compliance with standards, application of labels and seals, notation of field measurements that have been checked and special coordination requirements.
 - c. Miscellaneous submittals related directly to the Work (non-administrative) include warranties, maintenance agreements, workmanship bonds, statements of applicability, quality testing and certifying reports, copies of industry standards, operating and maintenance materials, devices and materials applicable to the Work but not processed as shop drawings, product data or samples.
4. Resubmissions: Clearly identify each correction or change made. The resubmission shall be accompanied by a letter listing all comments made by the Engineer and the actions or response by the manufacturer or vendor to each comment. Where the Engineer's comment applies to multiple areas of the initial submittal the response shall address all areas. The response letter shall also address where supplemental information has been provided and where it is located within the resubmission.
 5. Incomplete Submittal Submissions:
 - a. Engineer will return entire Submittal for Supplier's revision/correction and resubmission.
 6. Non-specified Submissions: Submissions not required under these Contract Documents and not shown on submittal logs generated by the Engineer will not be reviewed, but will be logged for information only, and will be returned to Supplier.
 7. Engineer's Review: Engineer will act upon Supplier's Submittal and transmit response to Supplier not later than 14 calendar days after receipt, unless otherwise specified. Resubmittals will be subject to same review time.
 8. Schedule Delays:
 - a. No adjustment of Contract Times or Price will be allowed due to Engineer's review of Submittals, unless all of the following criteria are met:
 - 1) Supplier has notified Engineer in writing that timely review of Submittal in question is critical to progress of Work, and has received Engineer's written acceptance to reflect such on current accepted submissions and progress schedule. Written agreement by Engineer to reduce Submittal review time will be made only for unusual and Supplier-justified reasons. Acceptance of a progress schedule containing Submittal review times less than specified or less than agreed to in writing by Engineer will not constitute Engineer's acceptance of review times.
 - 2) Engineer has failed to review and return first submission of a Submittal within agreed time indicated on current accepted schedule of submissions or, if no time is indicated thereon, within 14 calendar days after receipt.

- 3) Supplier demonstrates that delay in progress of Work is directly attributable to Engineer's failure to return Submittal within time indicated and accepted by Engineer.
- b. No adjustment of Contract Times or Price will be allowed due to delays in progress of Work caused by rejection and subsequent resubmission of Submittals, including multiple resubmissions.

1.2 SPECIFIC CATEGORY REQUIREMENTS

- A. General: Except as otherwise indicated in the individual work sections, comply with the general requirements specified herein for each indicated category of submittal. Include in submittals:
 1. The date of submittal and the dates of any previous submittals.
 2. The Project title.
 3. The submittal number.
 4. The Names of:
 - a. Supplier.
 - b. Manufacturer.
 5. Identification of the product, with the specification section number.
 6. Field dimensions, clearly identified as such.
 7. Relation to adjacent or critical features of the Work or materials.
 8. Applicable standards, such as ASTM or Federal Specification numbers.
 9. Notification to the Engineer in writing of any deviations to the requirements of the Contract Documents. The notification of deviation shall be clearly marked by the Supplier in the body of the submittal and stated in text in the Supplier's remarks on the transmittal document of the submittal. Indicate the reasons for the deviations and the benefits to the Project.
 10. Identification of revisions on resubmittals.
 11. An 8-inch by 4-inch blank space for Supplier's and Engineer's stamps.
 12. Cross out all non-pertinent information on submittal sheets or drawings showing more than one particular item under consideration.

1.3 ROUTING OF SUBMITTALS

- A. Route submittals and routine correspondence as follows:
 1. Supplier to Engineer.
 2. Engineer to Supplier and Owner.
- B. Additionally, if a submittal is for products, equipment or systems which interface with the Process Instrumentation and Control Systems Supplier (PICSS) or Instrumentation and Control System Integrator, such submittal shall be reviewed by the PICSS.

1.4 SUBMITTAL LOG

- A. Submittal Identification and Packaging: Incorporate submittals into packages, with submittal numbering as follows: XX XX XX.XX.YY, where 'X' denotes the applicable specification section and 'Y' denotes the individual submittal number for that particular specification section, beginning with 01. The initial submittal shall be identified as "Revision" 000. Subsequent resubmittals shall be identified 001, 002, etc. Packages shall

be identified as follows: XX XX XX.XXAA; where 'X' denotes the applicable specification section and 'A' indicates which submittals must be submitted together in a single package.

- B. Guarantees/Warranties: Provide a list of all required Guarantee/Warranty submittals. Identify these submittals as individual submittals within the submittal packages with numbering as specified above.
- C. Operation & Maintenance Manuals: Provide a list of all required Operation & Maintenance Manual (O&M) submittals. Identify these submittals as individual submittals within Section 01 78 23, rather than the corresponding equipment section.
- D. Test Reports: List these submittals as individual submittals within the submittal packages identified with numbering as specified above.
- E. Submittal Procedures: Prepare all submittal packages utilizing the submittal numbering system, description and packaging conventions described above. Submittals prepared by the Supplier, which fail to follow the conventions described above, will be returned "un-reviewed".
- F. Submittal Transmissions: To the maximum extent possible, transmit submittals to the Engineer electronically. Exceptions are shop drawings larger than 11-inches by 17-inches, samples and color charts which shall be transmitted electronically and in hard copy format. Other exceptions to the electronic format requirement must be approved by the Engineer. Electronic and hard copies of the O&M manuals shall be provided in accordance with Section 01 78 23.

PART 2 PRODUCTS

2.1 SHOP DRAWINGS

- A. Unless otherwise specifically directed by the Engineer, make all shop drawings accurately to scale and large enough and in sufficient detail to show all pertinent features of the submitted item and its method of connection to the Work.
- B. Submit all shop drawings electronically to the fullest extent possible. Supplier shall advise when shop drawings cannot be scanned and submitted electronically. In the limited cases where electronic submissions cannot be made, 6 copies of the submittal shall be provided. All electronically submitted shop drawings shall be in a searchable single file Adobe Acrobat Portable Document Format (PDF). The PDF file shall be fully indexed using the Table of Contents, searchable with thumbnails generated. Electronic files shall be scanned in no greater than 300 dpi utilizing optical character recognition (OCR) software. One signed electronic copy of the reviewed submittal shall be returned to the Supplier. Supplier will be responsible for additional markups required for additional distribution to suppliers and subcontractors.

2.2 MANUFACTURER'S LITERATURE

- A. Where the content of submitted literature from manufacturers includes data not pertinent to this submittal, clearly indicate which portion of the contents is being submitted for the Engineer's review.
- B. Submit manufacturer's literature electronically. The literature shall be reviewed and comments, if any, returned to the Supplier with the status of the submittal indicated. One electronic copy shall be returned to the Supplier.

2.3 ADMINISTRATIVE SUBMITTALS

- A. Copies: Submit electronically unless otherwise directed by the Engineer. When hard copies are to be submitted, provide a minimum of 6 copies.
- B. Description: Submittals that are not Shop Drawings or Samples, or that do not reflect quality of product or method of construction. May include, but not limited to those Submittals identified below.
- C. Applications for Payment (and Cash Allowance Data and Values): Meet requirements of Section 01 29 73.
- D. Training Materials: Meet the requirements of Section 01 43 33.
- E. Submittals Required by Laws, Regulations, and Governing Agencies:
 - 1. Submit promptly notifications, reports, certifications, payrolls, and otherwise as may be required, directly to the applicable federal, state, or local governing agency or their representative.
 - 2. Transmit to Engineer for Owner's records one copy of correspondence and transmittals (to include enclosures and attachments) between Supplier and governing agency.

2.4 QUALITY CONTROL SUBMITTALS

- A. Certificates:
 - 1. Manufacturer's Certificate of Compliance: As specified in Section 01 91 13.
 - 2. Certificates of Successful Testing or Inspection: Submit when testing or inspection is required by Laws and Regulations or governing agency or specified in the individual Specification sections.
 - 3. Manufacturer's Certificate of Proper Installation: As specified in Section 01 91 13.
- B. Operation and Maintenance Manual: As required in Section 01 78 23.
- C. Statements of Qualification: Evidence of qualification, certification, or registration. As required in these Contract Documents to verify qualifications of professional land surveyors, Engineers, materials testing laboratories, specialty subcontractors, trades, specialists, consultants, installers, and other professionals.
- D. Written Test Reports of Each Test and Inspection: As a minimum, include the following:
 - 1. Date of test and date issued, Project title and number, testing laboratory name, address, and telephone number, and name and signature of laboratory inspector.
 - 2. Date and time of sampling or inspection and record of temperature and weather conditions.
 - 3. Identification of product and Specification section, location of Sample, test or inspection in the Project, type of inspection or test with referenced standard or code, certified results of test.
 - 4. Compliance with Contract Documents, and identifying corrective action necessary to bring materials and equipment into compliance.
 - 5. Provide an interpretation of test results, when requested by Engineer.
- E. Disposition: Engineer will review, stamp, and indicate requirements for resubmission or acceptance on Submittal as follows:
 - 1. No Exceptions Noted (NEN)/ Furnish as Corrected (FAC):
 - a. An NEN or FAC status will indicate that Submittal conforms to intent of Contract Documents as to form and substance.
 - b. Supplier may proceed to perform Submittal related Work.

- c. For electronic submittals, one copy of electronic file will be provided to the Owner and Supplier.
- d. Distribution as follows for hard copy submittals:
 - 1) One copy furnished Owner.
 - 2) One copy retained in Engineer's file.
 - 3) Remaining copies returned to Supplier appropriately annotated.
- 2. Submit Specific Item (SSI), Revise & Resubmit (R&R) or Rejected (REJ):
 - a. One copy retained in Engineer's file.
 - b. One copy returned to Supplier appropriately annotated.
 - c. Supplier shall revise/correct or develop replacement and resubmit.

2.5 CONTRACT CLOSEOUT SUBMITTALS

- A. General: In accordance with Section 01 77 00.
- B. Disposition: Engineer will review, stamp, and indicate requirements for resubmission or acceptance on Submittal as follows:
 - 1. No Exceptions Noted (NEN)/ Furnish as Corrected (FAC):
 - a. An NEN or FAC status will indicate that Submittal conforms to intent of Contract Documents as to form and substance.
 - b. Contractor may proceed to perform Submittal related Work.
 - c. For electronic submittals, one copy of electronic file will be provided to the Owner and Supplier.
 - d. Distribution as follows for hard copy submittals:
 - 1) One copy furnished Owner.
 - 2) One copy retained in Engineer's file.
 - 3) One copy returned to Supplier appropriately annotated.
 - 2. Submit Specific Item (SSI), Revise & Resubmit (R&R) or Rejected (REJ):
 - a. One copy retained in Engineer's file.
 - b. One copy returned to Supplier appropriately annotated.
 - c. Supplier shall revise/correct or develop replacement and resubmit.

PART 3 EXECUTION

3.1 SUPPLIER'S COORDINATION OF SUBMITTALS

- A. Clearly indicate in a letter or memorandum on the manufacturer's or fabricator's letterhead, all deviations from the Contract Documents. Clearly mark the deviation in the body of the submittal and state the deviation on the transmittal form of the submittal. Describe the benefits and reasons for the deviation.
- B. Packaging of Submittals:
 - 1. Submittals shall be packaged. Submittals in packages shall be submitted simultaneously. Unless otherwise specifically permitted by the Engineer, make all submittals in packages containing all submittals indicated by the submittal log to be packaged together.

2. No review will be given to partial submittals or incomplete packages of submittals. It is the Supplier's responsibility to assemble the shop drawings for interconnecting and interdependent items, check them and then make one submittal to the Engineer along with Supplier's comments as to compliance, non-compliance or features requiring special attention.
- C. Design Data: When specified, provide Project-specific information as required and as necessary to clearly show calculations, dimensions, logic and assumptions, and referenced standards and codes upon which design is based.
- D. Foreign Manufacturers: When proposed, include following additional information:
1. Names and addresses of at least two companies closest to Project that maintain technical service representatives.
 2. Complete inventory of spare parts and accessories for each piece of equipment.
- E. Preparation:
1. Format: Whenever possible, schedule for and combine Shop Drawings and Samples required for submission in each Specification section or division into a single Submittal package. Also combine product data for like items into a single Submittal package.
 2. Present in a clear and thorough manner and of sufficient detail to show kind, size, arrangement, and function of components, materials, and devices and compliance with Contract Documents. Identify details by reference to sheet and detail, and schedule or room numbers shown on Drawings.
 3. Product Data: Clearly mark each copy to identify pertinent products or models and show performance characteristics and capacities, dimensions and clearances required, wiring or piping diagrams and controls, and external connections, anchorage, and supports required.
 4. Equipment and Component Titles: Identical to title shown in Specifications.
 5. Manufacturer's standard schematic drawings, diagrams, and product data as follows:
 - a. Modify to delete information that is not applicable to Work.
 - b. Supplement standard information to provide information specifically applicable to Work.

3.2 TIMING OF SUBMITTALS

- A. Make all submittals in accordance with the requirements of these Specifications. Time lost due to unacceptable submittals shall be the Supplier's responsibility.
- B. In scheduling, allow sufficient time for the Engineer's review following the receipt of the submittal.

3.3 REVIEWED SUBMITTALS

- A. Engineer Review:
1. Allow a minimum of 14 days for the Engineer's initial processing of each submittal requiring review and response, except allow longer periods for submittals needing coordination with subsequent submittals. The Engineer shall inform the Supplier promptly when it is determined that a submittal being processed must be held for coordination.
 2. Acceptable submittals with no review comment shall be marked "No Exceptions Noted". A submittal with an "NEN" status shall not be resubmitted.

3. Acceptable submittals with a minor comment or comments offered merely to alert the Supplier to some issue or provide information will be marked “Furnish as Corrected”. A submittal with an “FAC” status shall not be resubmitted.
 4. Submittals requiring minor corrections will be marked “Submit Specific Items”. A submittal with an “SSI” status must be completely resubmitted for review and marked “NEN” or “FAC” prior to installation or use of the submitted product. The resubmission shall be accompanied by a letter as referenced in Article 1.1.B.4. above. No payment will be made for materials stored onsite or incorporated into the work until the resubmittal obtains an “NEN” or “FAC” status.
 5. Submittals marked “Revise and Resubmit” must be resubmitted with revisions reflecting the Engineer’s comments. The resubmission shall be accompanied by a letter as referenced in Article 1.1.B.4. above. The Supplier shall not order, fabricate or ship items that correspond to an “R&R” submittal.
 6. Submittals marked “Rejected” are not acceptable. Upon return of a submittal so marked, the Supplier shall repeat the initial review procedure utilizing acceptable products.
- B. No product shall be installed that does not have a corresponding submittal bearing a status of “No Exceptions Noted” or “Furnish as Corrected”. Maintain at the job site a complete set of current submittals indicating the review status established by the Engineer.
- C. Substitutions: In the event the Supplier obtains the Engineer's approval for the use of products other than those which are listed first in the Contract Documents, the Supplier shall, at the Supplier's own expense and using methods approved by the Engineer, make any changes to structures, piping and electrical work that may be necessary to accommodate these products.
- D. Use of the “No Exceptions Noted” or “Furnish as Corrected” notation on shop drawings or other submittals is general and shall not relieve the Supplier of the responsibility of furnishing products of the proper dimension, size, quality, quantity, materials and all performance characteristics, to efficiently perform the requirements and intent of the Contract Documents. The Engineer's review shall not relieve the Supplier of responsibility for errors of any kind on the submittals. The Engineer’s review shall not relieve the Supplier of responsibility for errors therein and shall not be regarded as an assumption of risks or liability by the Engineer, Designer or the Owner, or by any officer or employee thereof, and the Supplier shall have no claim under the Contract on account of the failure, or partial failure, of the method of work, material or equipment so reviewed. Review is intended only to assure conformance with the design concept of the Project and compliance with the information given in the Contract Documents. The Supplier is responsible for dimensions to be confirmed and correlated at the job site. The Supplier is also responsible for information that pertains solely to the fabrication processes or to the technique of construction and for the coordination of the work of all trades.

3.4 RESUBMISSION REQUIREMENTS

- A. Accept full responsibility for the completeness of each resubmittal. Verify that all corrected data and additional information previously requested by the Engineer are provided on the resubmittal. Accompany the resubmission with a letter as referenced in Article 1.1.B.4. above. Clearly mark and alert the Engineer to the presence of changes within the resubmittal that are other than those required by the Engineer’s comments on the previous submittal. Requirements specified in initial submittals shall also apply to resubmittals.

END OF SECTION

SECTION 01 42 19

CODES AND STANDARDS

PART 1 GENERAL

1.1 SUMMARY

A. Section Includes

<u>Paragraph</u>	<u>Title</u>
1.2	Standard Organizations
1.3	Symbols

B. Description

1. Whenever reference is made to conform to the standards of any technical society, organization, body, code or standard, it shall be construed to mean the latest standard, code, specification or tentative specification adopted and published at the time of advertisement for Bids. This shall include the furnishing of materials, testing of materials, fabrication and installation practices. In those cases where the Contractor's quality standards establish more stringent quality requirements, the more stringent requirement shall prevail. Such standards are made a part hereof to the extent which is indicated or intended.
2. The inclusion of an organization under one category does not preclude that organization's standards from applying to another category.
3. In addition, all work shall comply with the applicable requirements of local codes, utilities and other authorities having jurisdiction.
4. All material and equipment, for which an Underwriter's Laboratories (UL) Standard, an American Gas Association (AGA) or National Sanitation Foundation (NSF) approval or an American Society of Mechanical Engineers (ASME) requirement is established, shall be so approved and labeled or stamped. The label or stamp shall be conspicuous and not covered, painted, or otherwise obscured from visual inspection.
5. The standards which apply to this Project are not necessarily restricted to those organizations which are listed in Paragraph 1.2.

1.2 STANDARD ORGANIZATIONS

A. Materials:

1. ANSI American National Standards Institute
2. ASTM American Society for Testing and Materials

B. Painting and Surface Preparation:

1. NACE National Association of Corrosion Engineers
2. SSPC The Society for Protective Coatings

C. Electrical and Instrumentation:

1. AEIC Association of Edison Illuminating Companies
2. AIEE American Institute of Electrical Engineers
3. EIA Electronic Industries Association
4. ICEA Insulated Cable Engineers Association

5. IEC International Electrotechnical Commission
 6. IEEE Institute of Electrical and Electronic Engineers
 7. IES Illuminating Engineering Society
 8. IPC Institute of Printed Circuits
 9. IPCEA Insulated Power Cable Engineers Association
 10. ISA The Instrumentation, Systems, and Automation Society
 11. NEC National Electric Code
 12. NEMA National Electrical Manufacturers Association
 13. NFPA National Fire Protection Association
 14. REA Rural Electrification Administration
 15. TIA Telecommunications Industries Association
 16. UL Underwriter's Laboratories
 17. VRCI Variable Resistive Components Institute
- D. Aluminum:
1. AA Aluminum Association
 2. AAMA American Architectural Manufacturers Association
- E. Welding:
1. ASME American Society of Mechanical Engineers
 2. AWS American Welding Society
- F. Government and Technical Organizations:
1. ASCE American Society of Civil Engineers
 2. ASQC American Society of Quality Control
 3. ASSE American Society of Sanitary Engineers
 4. CFR Code of Federal Regulations
 5. CSI Construction Specifications Institute
 6. EPA Environmental Protection Agency
 7. ISO International Organization for Standardization
 8. NFPA National Fluid Power Association
 9. NBS National Bureau of Standards
 10. OSHA Occupational Safety and Health Administration
 11. WEF Water Environment Federation
- G. Refrigeration, Heating, and Air Conditioning:
1. AMCA Air Movement and Control Association
 2. ARI American Refrigeration Institute
 3. ASHRAE American Society of Heating, Refrigeration, and Air Conditioning Engineers
 4. ASME American Society of Mechanical Engineers

H. Equipment:

1. AFBMA Anti-Friction Bearing Manufacturers Association, Inc.
2. AGMA American Gear Manufacturers Association

1.3 SYMBOLS

- A. Symbols and material legends shall be as scheduled on the Drawings.

PART 2 PRODUCTS (NOT USED)

PART 3 EXECUTION (NOT USED)

END OF SECTION

MANUFACTURER SERVICES

PART 1 GENERAL

1.1 SUMMARY

A. Section Includes

<u>Paragraph</u>	<u>Title</u>
1.2	Qualification
1.3	Submittals
1.4	Coordination
1.5	Installation, Start-up, and Testing Services
1.6	Operator Training Services
1.7	Documentation

B. Scope

1. The work under this Section defines the minimum scope of services to be provided by the Supplier during installation, testing, start-up, and operator training using factory representatives of the manufacturers of the installed equipment.
2. Furnish all labor, materials, tools, equipment, and services for the cleaning up or preparation of all equipment which is required in conjunction with the instruction work to be performed for the Owner's personnel.
3. Although such work may not be explicitly specifically indicated elsewhere, furnish and install all supplementary or miscellaneous items, appurtenances and devices incidental to or necessary for a sound, secure and complete installation, and to provide instructions upon the functions of that installation.
4. Provide instruction for all equipment and systems for which operating and maintenance data is required.
5. Instruction sessions may be combined to some extent between several pieces of similar equipment within the same training session, but only if that combination is defined in the Supplier's instruction program submittal and approved by the Engineer.
6. A minimum of one instruction session or two 1/2-day sessions for each major type of equipment will be required. Anticipate that up to ten of the Owner's employees will participate in any particular instruction session, and be prepared to provide the required number of handouts, manuals, and tools for each session.
7. Perform additional instruction of the Owner's personnel for any and all items of work that are incomplete at the time initial instruction sessions are scheduled.

1.2 QUALIFICATIONS

- A. Qualification of the manufacturer's representatives for installation, start-up, and operator training purposes shall be appropriate for the equipment being installed. Manufacturer's representatives shall be subject to the approval of the Engineer. Where equipment has significant process complexity, furnish the services of engineering personnel knowledgeable in the process involved and the function of the equipment.

- B. References in various equipment sections of the terms “factory representative” or “field representative” shall mean an employee of the equipment manufacturer who is completely knowledgeable of the manufacturing, installation, operation and maintenance of the equipment. A sales representative does not qualify. Any field or factory representative not an active employee of the manufacturer must provide documentation from the manufacturer stating that the individual, by name, has been formally trained in the installation, operation and maintenance of the equipment and is authorized to make the required certification to perform the required services.

1.3 SUBMITTALS

- A. Submit a list of proposed instruction sessions for the entire Project no later than ninety days prior to scheduled Substantial Completion of the Work. Organize the list by Specification Section and its contents will be subject to the approval of the Engineer and Owner.
- B. After approval of the list of the proposed instruction sessions and no later than sixty days prior to the scheduled Substantial Completion of the Work, submit course outlines for each of the approved instruction sessions. Outlines shall be organized by Specification Section, and their contents will be subject to the approval of the Engineer. Include both classroom and hands-on training in the outlines.
- C. After approval of the program content, submit a proposed schedule for each of the approved instruction sessions which are to be organized by Specification Section, and the scheduled dates will be subject to the approval of the Engineer.
- D. Submit a separate instruction request/report for each system or type of equipment, subject to the Owner’s approval of availability of personnel.
 - 1. Submit request/report with preliminary information indicated, to the Engineer at least two weeks prior to first instruction period.
 - 2. After each instruction session, submit three copies of the completed report to the Engineer.

1.4 COORDINATION

- A. Do not begin instructions until component assembly or system has been tested as specified in Section 01 91 13 and is in satisfactory operating condition.
- B. Prior to instruction sessions, assemble instructional aids, tools, test equipment, and “Final” copies of Operations and Maintenance Manuals.
- C. All instruction sessions shall be planned and scheduled such that the Owner’s participants will utilize “Final” copies of the Project Operations and Maintenance Manuals which will have been previously provided. These copies are in addition to the quantities which have to be provided to the Owner under Section 01 78 23. The use of preliminary or draft copies of these manuals will not be acceptable.
- D. Schedule and coordinate the visits of factory representatives during installation, start-up and operator training in accordance with the requirements of Section 01 91 13 of these Specifications.
- E. Notify the Engineer 72 hours prior to any impending visit by factory representatives so that the Engineer can be present.

1.5 INSTALLATION, START-UP, AND TESTING SERVICES

- A. Furnish the services of a factory representative to provide the pre-start-up maintenance, installation, inspection, functional testing, and operational testing in accordance with Section 01 91 13 and the equipment sections of these Specifications.

- B. Perform installation, start-up, and testing services in advance of operator training. Operator training services are to be provided on a separate day from start-up and testing services, unless approved otherwise by the Owner.

1.6 OPERATOR TRAINING SERVICES

- A. Provide all instruction as required to ensure understanding of all operating and maintenance procedures by the Owner designated personnel.
- B. Instruct Owner's personnel in operation and maintenance of equipment and systems. Provide all necessary instruction to satisfaction of the Owner.
- C. Schedule training sessions at the convenience of the Owner. Training sessions may have to be scheduled outside of the Supplier's normal working hours.
- D. Explain use of Operating and Maintenance Manuals.
- E. Tour building areas involved and identify:
 - 1. Maintenance and access points.
 - 2. Control locations and control equipment.
- F. Explain operating sequences:
 - 1. Identify location and show operation of switches, valves, etc., used to start, stop, and adjust systems.
 - 2. Explain use of flow diagrams, operating sequences, diagrams, etc.
 - 3. Demonstrate operation through complete cycle(s) and full range of operation in all modes, including testing and adjusting relevant to operation.
- G. Explain use of control equipment, including temperature settings, switch modes, available adjustments, reading of gauges, and functions that must be serviced only by authorized factory representative.
- H. Explain troubleshooting procedures:
 - 1. Demonstrate commonly occurring problems.
 - 2. Note procedures which must be performed by factory personnel.
- I. Explain maintenance procedures and requirements:
 - 1. Point out items requiring periodic maintenance.
 - 2. Demonstrate typical preventive maintenance procedures and recommend typical maintenance intervals.
 - 3. Demonstrate other commonly occurring maintenance procedures not part of preventive maintenance program.
 - 4. Identify maintenance materials to be used.
- J. Furnish all tools and/or test equipment required for proper instruction of the Owner's personnel. Distribute tools and/or test equipment in "sets" with each two participants having a "set" to work with and retain upon completion of the instruction. Each participant shall sign for their tools at the start of the instruction session, and copies of the assignment documents shall be provided to the Engineer by the Supplier.
- K. Thirty-day operating period after start-up: The manufacturers' representative for each piece of equipment shall return to the project site 30 days after successful completion of the operating test to review the equipment performance, correct any equipment problems, and conduct follow-up operation and maintenance classes as required by the Owner. This follow-up trip is required in addition to the specified services of manufacturer's

representative prior to and during equipment start-up. At this time, if there are no equipment problems, each manufacturer shall certify to the Owner in writing that his equipment is fully operational and capable of meeting operating requirements. If the certification is accepted by the Engineer and Owner, the warranty period for that piece of equipment shall be considered to have begun as of the start-up date. If the equipment is operating incorrectly, the factory representative will make no certification to the Owner until the problems are corrected and the equipment demonstrates a successful 30 days operating period. At the conclusion of that period, the warranty start date will be decided upon by the Owner.

- L. Six month operating period after start-up: The manufacturer's representative for each piece of equipment shall return to the project site six months after the successful completion of the operating test to review the equipment performance, correct any equipment problems, and conduct follow-up operation and maintenance classes as required by the Owner. This follow-up trip is required in addition to the specified services of manufacturer's representative prior to and during equipment start-up. At the time of this trip, if there are no equipment problems, each manufacturer shall certify to the Owner in writing that his equipment is fully operational and capable of meeting operating requirements. If the equipment is operating incorrectly, the service representative will make no certification to the Owner until the problems are corrected and the equipment demonstrates a successful 30-day operating period after problems are corrected.

1.7 DOCUMENTATION

- A. Obtain from all manufacturers an electronic file of all operation and training information and training presentation materials in searchable Adobe Acrobat Portable Document Format (PDF). Fully index the PDF file using the Table of Contents, searchable with thumbnails generated. File(s) shall be identified by specification section. Scan all documents at 300dpi or greater utilizing optical character recognition (OCR) software. All text in the document must be text selectable with the exception of pages which are in their entirety drawings or diagrams. Word searches of the PDF document must function successfully. PDF files that fail to comply with the indexing and searchable features described above will not be acceptable.
- B. At the completion of each training session, the training session will be certified by representatives from the Manufacturer, Supplier, Owner, and Engineer. Deliver a training attendance roster for each session identifying all participants to the Engineer.

PART 2 PRODUCTS (NOT USED)

PART 3 EXECUTION (NOT USED)

END OF SECTION

SECTION 01 60 00

GENERAL EQUIPMENT STIPULATIONS

PART 1 GENERAL

1.1 SUMMARY

A. Section Includes

<u>Paragraph</u>	<u>Title</u>
1.2	Unit Responsibility
1.3	Patent Royalties
1.4	Equipment Warranty
1.5	Workmanship and Materials
1.6	Equipment Specifications
1.7	Electrical Requirements
1.8	Operating Fluids and Gases
1.9	Lubrication and Lubrication Fittings
1.10	Control and Instrumentation Components
1.11	Special Tools and Accessories
1.12	Shop Testing
1.13	Shop Priming and Painting
1.14	Vibration Testing
1.15	Noise Criteria
1.16	Failure of Equipment to Perform

B. Scope

1. These general equipment stipulations apply, in general, to all equipment and piping. They supplement the detailed equipment Specifications, but in case of conflict, the detailed equipment Specifications shall govern.
2. Furnish, install, test, and place in acceptable operation all mechanical equipment and all necessary accessories as specified herein, as shown on the Drawings, and as required for a complete and operable system.
3. Provide mechanical equipment complete with all accessories, special tools, spare parts, mountings, and other appurtenances as specified, and as may be required for a complete and operating installation.
4. It is the intent of these Specifications that the Supplier provide the Owner complete and operational equipment/systems. To this end, it is the responsibility of the Contractor to coordinate all interfaces with related mechanical, structural, electrical, instrumentation and control work and to provide necessary ancillary items such as controls, wiring, etc., to make each piece of equipment operational as intended by the Specifications.
5. The completed installation shall be free from excessive vibration, cavitation, noise, and oil or water leaks.

1.2 UNIT RESPONSIBILITY

- A. Equipment manufacturers assigned unit responsibility for systems comprised of several components shall be responsible for furnishing a complete system in accordance with the requirements of these Specifications. The manufacturer shall be responsible for all coordination between component manufacturers and shall provide all submittals, installation and start-up services and certifications on the system as a unit.

1.3 PATENT ROYALTIES

- A. Include the cost of all royalties and fees for patents covering materials, articles, apparatus, devices or equipment in prices bid.

1.4 EQUIPMENT WARRANTIES

- A. Warrant all equipment against faulty or inadequate design, improper assembly or erection, defective materials, breakage or other failure. The warranty period shall be defined in Section 01 78 33 of these Specifications.

1.5 WORKMANSHIP AND MATERIALS

- A. Design, fabricate, and assemble all equipment in accordance with the most modern engineering and shop practice. Individual parts shall be manufactured to standard sizes and gauges so that repair parts, furnished at any time, can be installed in the field. Like parts of duplicate units shall be interchangeable. Equipment shall be new and shall not have been in service at any time prior to delivery, except as required by tests.
- B. Provide materials suitable for service conditions. Iron castings shall be tough, close grained, gray iron free from blowholes, flaws or excessive shrinkage and shall conform to ASTM A48, Class 30 minimum. Plugging of defective castings shall not be permitted. Castings shall be annealed to remove internal stresses prior to machining and shall have the mark number and heat number cast on them.
- C. Except where otherwise specified, structural and miscellaneous fabricated steel used in items of equipment shall conform to the Standards of the American Institute of Steel Construction. All structural members shall be considered as subject to shock or vibratory loads.
- D. Make all replaceable or expendable elements such as filters, screens, drive belts, fuses and lamps easily accessible and replaceable without need of dismantling equipment or piping. Provide standard type of all such items that are readily available from multiple suppliers.
- E. Provide stainless steel plugs for threaded openings for drains or vents in pump volutes, compressor or fan scrolls, air receivers, and heat exchangers which are plugged during normal operation.
- F. Include detailed installation instructions and a parts list for all equipment delivered to the Project site.
- G. Isolate all dissimilar metals to the satisfaction of the Engineer.

1.6 EQUIPMENT SPECIFICATIONS

- A. The use of singular or plural terminology in the Specifications is not intended to define the number of units required to fulfill Contract requirements. Bidders must consult the Drawings and Specifications to determine how many units of a particular piece of equipment are required. This does not relieve the Supplier of the responsibility to provide all equipment specified when multiple units are specifically required in the Specifications.

1.7 ELECTRICAL REQUIREMENTS

- A. All electrical equipment and appurtenances, including but not limited to motors, panels, conduit and wiring, etc., specified in the equipment specifications shall comply with the applicable requirements of the latest National Electric Code.
- B. In the individual equipment specifications, specified motor horsepower is intended to be the minimum size motor to be provided. If a larger motor is required to meet the specified operating conditions and performance requirements, furnish the larger sized motor at no additional cost to the Owner.
- C. Furnish and install motor starters and controls under Division 26 and Division 40 unless otherwise specified in the individual pump specifications.

1.8 OPERATING FLUIDS AND GASES

- A. Provide in sufficient quantity of all operating fluids and gases recommended by the manufacturer and required for operation of the equipment to fill all equipment and to replace all fluids and gases consumed during testing and start-up.

1.9 LUBRICATION AND LUBRICATION FITTINGS

- A. Equipment shall be adequately lubricated by systems which require attention no more frequently than weekly during continuous operation. Lubrication systems shall not require attention during start-up or shutdown and shall not waste lubricants.
- B. Provide in sufficient quantities lubricants of the type recommended by the equipment manufacturer to fill all lubricant reservoirs and to replace all lubricants consumed during testing, start-up and initial operation. Provide sufficient quantities of lubricants to lubricate all equipment for one year of normal service before final acceptance of the equipment will be made by the Owner.
- C. When special run-in oil or storage lubricants are used, flush out and replace with the required service lubricant.
- D. Tag each piece of equipment with a cloth tag showing proper type lubricant, period between lubrications, date of lubrication and worker's initials. Have space for 10 lubrication notations.
- E. Except for rotating shaft couplings, bring all lubrication fittings to the outside of all equipment so that they are readily accessible from the outside without the necessity of removing covers, plates, housings or guards. Make fittings accessible from safe, permanent platforms or walk areas. Provide bull-neck, check type fittings for use with a portable high pressure grease gun. Provide minimum 3/16-inch stainless steel tubing, securely mounted parallel to equipment lines and protected where exposed to damage for connection from a remote fitting to the point of use.

1.10 CONTROL AND INSTRUMENTATION COMPONENTS

- A. Control and instrumentation equipment furnished by the mechanical equipment manufacturer shall conform to the applicable requirements of Divisions 26 and 40.

1.11 SPECIAL TOOLS AND ACCESSORIES

- A. Equipment requiring periodic repair and adjustment shall be furnished complete with all special tools, instruments and accessories required for proper maintenance. Special tools and accessories shall include those tools and accessories not normally available in an industrial hardware or mill supply house. Equipment requiring special devices for lifting or handling shall be furnished complete with those devices.

1.12 SHOP TESTING

- A. Test all equipment in the shop of the manufacturer in a manner which conclusively proves that its characteristics comply fully with the requirements of the Contract Documents and that it will operate in the manner specified or implied.
- B. Do not ship any equipment to the project until the Engineer has been furnished a certified copy of test results and has notified the Supplier, in writing, that the results of such tests are acceptable.
- C. Forward seven (7) certified copies of the manufacturer's actual test data and interpreted results thereof to the Engineer for review.
- D. If required by the individual equipment Specifications, make arrangements for the Owner/Engineer to witness performance tests in the manufacturer's shop. Notify the Engineer ten (10) working days before shop testing commences. Expenses are to be paid by Supplier.
- E. Shop test electric motors in accordance with applicable requirements of Section 26 00 01, General Electrical Provisions.

1.13 SHOP PRIMING AND PAINTING

- A. Comply with the requirements of Section 09 91 00 of these Specifications for all equipment shop priming and painting, including surface preparation, workmanship and materials.

1.14 VIBRATION TESTING

- A. Test in the field for acceptable vibration levels, each pump or blower having a rated power of 50 HP, or greater, unless specified otherwise in the Specifications. Vibration testing shall be performed by an experienced, factory-trained and authorized vibration analysis expert (not a sales representative) retained by the Supplier for this work. Test each unit separately without duplicate equipment running. Perform all field testing in the presence of the Engineer. Furnish to the Engineer four certified copies of vibration test data for each test performed.
- B. Where specified in the Specifications, equipment which is assembled and tested on the manufacturer's floor shall also be checked triaxially for vibration by the manufacturer. Submit the results of these tests, along with location of vibration check points, to the Engineer. Make all readings on an X-Y recorder with appropriate scales indicated and an explanation thereon of any recordings exceeding specified limits. The field tests shall include substantiation of the manufacturer's test data.
- C. For systems with variable speed drives, conduct tests at various speeds between maximum and minimum. For systems with two-speed drives, conduct tests at both speeds. For systems with constant-speed drives, conduct tests under various loading conditions as determined by the Engineer.
- D. Test rotating equipment for vibration in the field after installation by the following method. Equipment, complete with drive systems, in place at the job site, shall not vibrate more than the values allowed herein, unless otherwise specified in the detailed equipment specifications. All field tests shall be running tests with the equipment operating on the product for which it is intended or a substitute acceptable to the Engineer. The term displacement, as used herein, shall mean total peak-to-peak movement of vibrating equipment, in mils; velocity shall mean the peak velocity or speed of the vibrating equipment, in inches per second; acceleration shall mean the maximum acceleration which occurs during the vibration cycle, measured in Gs. Displacement and velocity shall be measured by a meter equal to IRD Mechanalysis Vibration Meter Model 306, or Bently-Nevada Model TK-8. Acceleration shall be measured by suitable equipment equal to IRD Mechanalysis or Bently-Nevada, subject to approval of the Engineer. Frequency of vibration, in cycles per minute (cpm), shall be determined when vibration exceeds specified

levels or as otherwise necessary. Vibration shall be measured on the bearing housing, unless other locations are deemed necessary by the vibration analysis expert and Engineer.

- E. For all equipment tested, check vibration in the radial and axial directions. For pumps, vibration shall not exceed that permitted by the Hydraulic Institute.
- F. Critical speeds of all rotating equipment shall meet the following:
 - 1. For stiff shaft designs, the first critical speed of the rotating equipment shall be at least 25 percent above the maximum design operating speed.
 - 2. For flexible shaft designs, critical speeds shall be at least 2 percent above or below normal design operating speeds.
- G. The Supplier shall be responsible for vibration testing unit and system assembly and results, which shall be within the specified limits. Copies of test results shall be submitted to the Engineer for review. Should the vibration field test results exceed shop test results or the limits specified herein, the Supplier shall correct the deficiencies within 30 days. After corrections have been completed, the vibration testing shall be rerun and the results resubmitted to the Engineer for review.

1.15 NOISE CRITERIA

- A. Unless otherwise specified, noise levels for all operating equipment shall not exceed 90 dB at 5 feet from the equipment when measured on the A scale of a calibrated sound level meter at slow response.
- B. Meet noise criteria without the use of special external barriers or enclosures.

1.16 FAILURE OF EQUIPMENT TO PERFORM

- A. Promptly correct any defects in the equipment or failure to meet the guarantees or performance requirements of the Specifications by replacements or otherwise.
- B. If the Supplier fails to make these corrections, or if the improved equipment fails again to meet the guarantees or specified requirements, the Owner, notwithstanding his having made partial payment for work and materials which have entered into the manufacture of said equipment, may reject said equipment and order the Supplier to remove it from the premises at the Supplier's expense.
- C. Upon receipt of said sums of money, the Owner will execute and deliver to the Supplier a bill of sale of all his rights, title, and interest in and to said rejected equipment; provided, however, that said equipment shall not be removed from the premises until the Owner obtains from other sources other equipment to take the place of that rejected.
- D. Said bill of sale shall not abrogate Owner's right to recover damages for delays, losses, or other conditions arising out of the basic contract.

PART 2 PRODUCTS (NOT USED)

PART 3 EXECUTION (NOT USED)

END OF SECTION

SECTION 01 65 00

TRANSPORTATION AND HANDLING

PART 1 GENERAL

1.1 SUMMARY

A. Section Includes

<u>Paragraph</u>	<u>Title</u>
1.2	Preparation for Shipment
1.3	Transportation
1.4	Handling

B. Scope

1. Provide transportation of all equipment, materials and products furnished under these Contract Documents to the Work site. In addition, provide preparation for shipment, loading, unloading, handling and preparation for installation and all other work and incidental items necessary or convenient to the Supplier for the satisfactory prosecution and completion of the Work.
2. Repair or replace all equipment, materials and products damaged during transportation or handling at no additional cost to the Owner prior to being incorporated into the Work.

1.2 PREPARATION FOR SHIPMENT

- A. When practical, factory assemble products. Matchmark or tag separate parts and assemblies to facilitate field assembly. Cover machined and unpainted parts that may be damaged by the elements with a strippable protective coating.
- B. Package products to facilitate handling and protect from damage during shipping, handling, and storage. Mark or tag outside of each package or crate to indicate its purchase order number, bill of lading number, contents by name, name of Project (Pump Station), Equipment number, and approximate weight. Include complete packing lists and bills of materials with each shipment.
- C. Spare Parts, Special Tools, Test Equipment, Expendables, and Maintenance Materials:
 1. Furnish as required by the Specifications at time of delivery of equipment.
 2. Properly package to avoid damage, in original cartons insofar as possible. Replace parts damaged or otherwise inoperable.
 3. Firmly fix to, and prominently display on, each package.
 - a. Minimum 3-inch by 6-inch manila shipping tag with the following information:
 - 1) Manufacturer's part description and number.
 - 2) Applicable equipment description.
 - 3) Quantity of parts in package.
 - 4) Equipment manufacturer.
 - 5) Applicable Specification section.
 - 6) Name of Pump Station.
 4. Deliver materials to Owner's designated facility.

- D. Protect equipment from exposure to the elements and keep thoroughly dry and dust-free at all times. Protect painted surfaces against impact, abrasion, discoloration, or other damage. Grease or oil all bearings and similar items.
- E. For major equipment items, request a minimum 7-day advance notice of shipment from manufacturers. Upon receipt of manufacturer's advance notice of shipment, promptly notify Engineer of anticipated date of equipment arrival.
- F. Factory Test Results: Reviewed and accepted by Engineer before product shipment as required in individual Specification sections.

1.3 TRANSPORTATION

- A. Suitably box, crate or otherwise protect all equipment during transportation.
- B. Where equipment will be installed using existing cranes or hoisting equipment, ensure that the weights of the assembled sections do not exceed the capacity of the cranes or hoisting equipment.
- C. Remove small items and appurtenances such as gauges, valves, switches, instruments and probes which could be damaged during shipment from the equipment prior to shipment. Package and ship these items separately. Plug or seal all openings to prevent the entrance of water or dirt.

1.4 HANDLING

- A. Handle products in accordance with the manufacturer's written instructions, and in a manner to prevent damage. Store products, upon delivery, in accordance with manufacturer's instructions, with labels intact and legible, in approved storage yards or sheds. Provide manufacturer's recommended maintenance during storage, installation, and until products are accepted for use by Owner.
- B. Strictly follow lifting and handling drawings and instructions furnished by the manufacturer or supplier. Use eyebolts or lifting lugs furnished on the equipment in handling the equipment. Do not use shafts and operating mechanisms as lifting points. Use spreader bars or lifting beams when the distance between lifting points exceeds that permitted by standard industry practice.
- C. Under no circumstances shall equipment or products be thrown or rolled off of trucks onto the ground.
- D. Use padded slings and chains, as required, to prevent damage to protective coatings and finishes.

PART 2 PRODUCTS (NOT USED)

PART 3 EXECUTION (NOT USED)

END OF SECTION

OPERATING AND MAINTENANCE DATA

PART 1 GENERAL

1.1 SUMMARY

A. Section Includes

<u>Paragraph</u>	<u>Title</u>
1.2	Submittal Schedule
1.3	Submittal Format
1.4	Contents of Operating and Maintenance Manual

B. Scope

1. Provide four (4) copies of a complete and comprehensive reference manual (Operating and Maintenance Manual) containing operating and maintenance data to enable operators and plant engineers to correctly operate, service and maintain all equipment and accessories covered by the Specifications and Drawings. The data contained in the manual shall explain and illustrate clearly and simply all principles and theory of operation, operating instructions, maintenance procedures, calibration procedures and safety precautions and procedures for the equipment involved.
2. Include the cost of the Operating and Maintenance Manual in the Contract Price. No separate payment will be made for the Operating and Maintenance Manual.
3. Start-up will not be permitted until Operation and Maintenance manuals have been submitted to and approved by the Engineer.

1.2 SUBMITTAL SCHEDULE

- A. Submit, for the Engineer's approval, a PDF of preliminary drafts of proposed formats and outlines of contents of manuals within 30 calendar days after the Notice to Proceed. The Engineer will notify the Supplier, in writing, of any deficiencies in the manual and will return one copy of the manual for completion and/or correction.
- B. Submit a PDF of preliminary manuals before the work covered by the Contract Documents before shipment of the equipment. The Engineer will notify the Contractor, in writing, of any deficiencies in the manual and will return one copy of the manual for completion and/or correction.
- C. Resubmissions: Clearly identify each correction or change made. Provide a letter listing all comments made by the Engineer and the actions or response by the manufacturer or vendor to each comment with the resubmission. Where the Engineers comment applies to multiple areas of the initial submittal address all areas in the response. Identify where supplemental information has been provided and where it is located within the resubmission in the response letter.
- D. Submit three final copies of the revised and completed manual, complete in detail as specified below when the equipment is shipped. Also submit three copies of the manual in digital format as specified below.
- E. Digital Copies of Manuals: Provide Operations and Maintenance Manuals in digital format concurrently with both the preliminary and final hard copy submissions. Materials available in digital format shall be furnished in accordance with the following:

1. Provide all textual data as an electronic file in searchable Adobe Acrobat Portable Document Format (PDF). The PDF file(s) shall be fully indexed using the Table of Contents, searchable with thumbnails generated. File(s) shall be identified by utilization of a “six dot two dot two” convention (XXXXXX.XX.YY.pdf) where X is the eight digit number corresponding to the specification section, and YY is an identification number. All documents shall be scanned at 300dpi or greater utilizing optical character recognition (OCR) software. All text in the document must be text selectable with the exception of pages which are in their entirety drawings or diagrams. Word searches of the PDF document must function successfully. PDF files that fail to comply with the indexing and searchable features described above will not be acceptable. All drawing data shall be provided in DWG version 2010 format or higher.
2. Materials not available in original digital format (available only in paper format) shall be scanned as noted above into a PDF format and cleaned to remove smudges, fingerprints, artifacts, and other extraneous marks. Include the following features, as applicable:
 - a. Preserve all notes, version stamps, etc.
 - b. Color maps: scanned in not less than the number of colors of the document or 16 colors, whichever is greater.
 - c. Color photographs: saved in not less than 256 colors.
 - d. Black and white or monochrome scans (non-text): minimum 16 gray scale levels.
 - e. File Type: save color maps, color photographs, and black and white and gray scale photograph files as GIF or JPG files, compatible with Adobe Photoshop Version 4.0.
 - f. Scan documents in the existing color format of the document, i.e. color documents shall be scanned in color, and black and white or monochrome in gray scale.
3. After the documents are in correct digital format, furnish them to the Engineer on flash drives. Provide a label including the required information or the O&M Manual cover sheet identified in Article 1.3, paragraph C of this Section. Provide a detailed paper printout of the files on the media with all media transmittals. This printout is to include a file name, file size, date of creation, submittal number, and a brief but accurate description of the file. Provide two (2) copies of the flash drive for each Operation and Maintenance Manual to the Engineer.

1.3 SUBMITTAL FORMAT

- A. Assemble each hard copy of the manual in one or more loose leaf binders, each with title page, typed table of contents, typed list of tables, typed list of figures, and heavy section dividers with reinforced holes and numbered plastic index tabs. Provide uniform 3-ring, hardback type, with transparent vinyl pocket front cover suitable for inserting identifying cover and with a transparent vinyl pocket on the spine for label binders for all manuals. All data shall be punched for binding. Arrange composition and printing so that punching does not obliterate any data. Include the project title, specification section number and title, and manual title on the cover and binding edge of each manual, all as approved by the Engineer.
- B. Reduce all copies of shop drawings, figures and diagrams to either 8-1/2 x 11-inches or to 11-inches in the vertical dimension and as near as practical to 17-inches in the horizontal dimensions. Fold such sheets to 8-1/2 x 11-inches. Print the manual and other data on first quality paper, 8-1/2 x 11-inch size with standard 3-hole punching. Label Vol. 1 of “X”, Vol. 2 of “X”, etc., where “X” is the total number of volumes in the set where more than one is required. Include the table of contents for the entire set, identified by volume

number in each binder. Text, figures and drawings shall be clearly legible and suitable for dry process reproductions.

- C. Provide a cover sheet that includes the following information with each submittal:
 - 1. The date of submittal and the dates of any previous submittals.
 - 2. The Project title.
 - 3. Submittal numbering in accordance with Section 01 33 23 of these Specifications.
 - 4. The names of:
 - a. Supplier
 - b. Manufacturer
 - 5. Identification of the product, with the Specification section number, permanent equipment tag numbers and applicable Drawing No.
- D. The Engineer will not recommend final acceptance of the Work until the Operating and Maintenance Manual is complete and satisfactory to Engineer.

1.4 CONTENTS OF OPERATING AND MAINTENANCE MANUAL

- A. Include a title page which includes all information specified in Article 1.3, paragraph C. of this Section in each manual. In addition, include manufacturer's address, phone number, facsimile number, and contact; manufacturer's equipment name and model number; supplier's address, phone number, facsimile number, and contact on the title page.
- B. Include a table of contents identifying the location of each item listed below, for each component supplied in each manual. For items not applicable to a component, the table of contents shall list N/A for the page number.
- C. For all equipment, furnish a complete, detailed listing of all equipment, components and accessories showing component name, manufacturer, model number and quantity information as outlined below:
 - 1. Provide a summary page for each piece of equipment detailing the following information:
 - a. Equipment Number
 - b. Equipment Description
 - c. Serial Number
 - d. Model Number
 - e. Manufacturer
 - 1) Address
 - 2) Phone
 - 3) Representative
 - f. Supplier
 - 1) Address
 - 2) Phone
 - 3) Representative
 - g. Local Service Provider
 - 1) Address
 - 2) Phone

- 3) Representative
 - h. Location of Equipment
 - i. Equipment Design Criteria
 - 1) HP
 - 2) Flow Rate, etc.
 - j. Performance Data
 - k. Normal Operating Characteristics
 - l. Limiting Conditions
- 2. Detailed disassembly, overhaul and reassembly, installation, alignment, adjustment and checking instructions.
- 3. Detailed operating instructions for start-up, calibration, routine and normal operation, regulation and control, safety, shutdown and emergency conditions. Detailed list of settings for relays, pressure switches, temperature switches, level switches, thermostats, alarms, relief valves, rupture discs, etc.
- 4. Detailed preventative maintenance procedures and schedules, including detailed lubrication instructions and schedules, identification of required lubricants and operating fluids (description, specification and trade name of at least two manufacturers), and diagrams illustrating lubrication points.
- 5. Detailed guide to equipment and/or process “troubleshooting”.
- 6. Detailed parts lists identified by title, materials of construction, manufacturer's part number, list of recommended spare parts identified as specified above, current cost list for recommended spare parts, predicted life of parts subject to wear, and an exploded or concise cut-away view of each equipment assembly. The manufacturer’s part numbers must match those used for the spare parts, documentation, identification, and turn-over. Should no spare parts be required, state in the Table of Contents that “No spare parts are required”.
- 7. Electrical and instrumentation schematics, including motor control centers, control panels, wiring diagrams, instrument panels and analyzer panels. All panels must have as-built schematics inside them at contract close-out.
- 8. List of all special tools supplied and description of their use. Special tools include any tool not normally available in an industrial hardware or mill supply house. Should no special tools be required, state in the Table of Contents that “No special tools are required”.
- 9. List of names and addresses of nearest service centers for parts, overhaul and service.
- 10. Procedures for storing, handling and disposing of any chemicals or products used with the equipment or system.
- 11. For equipment and systems, also provide the following:
 - a. Control and wiring diagrams provided by the controls manufacturer.
 - b. Sequence of operations by the controls manufacturer.
 - c. Charts of valve tag numbers, with location and function of each valve, keyed to flow and control diagrams.
- 12. The supplier's operation and maintenance information will address the particular equipment furnished, with specific details on operation and maintenance practices. General data is not acceptable. Information contained in the manual which is not appropriate to the Project shall be marked out and noted as “N/A”.

PART 2 PRODUCTS (NOT USED)

PART 3 EXECUTION (NOT USED)

END OF SECTION

WARRANTIES AND BONDS

PART 1 GENERAL

1.1 PROJECT MAINTENANCE AND WARRANTY

- A. Maintain and keep in good repair the Work covered by these Drawings and Specifications until acceptance by the Owner.

NTS: Select length of warranty period

- B. Warrant for a period of 2-years from the date of Start-up of the pumping equipment and/or Owner's written final acceptance of the Project, as defined in the Contract Documents, that the completed Work is free from all defects due to faulty products or workmanship. Promptly make such corrections as may be necessary by reason of such defects. The Owner will give notice of observed defects with reasonable promptness. In the event that the Supplier should fail to make such repairs, adjustments or other work that may be made necessary by such defects, the Owner may do so and charge the Supplier the cost thereby incurred. The Performance Bond shall remain in full force and effect throughout the warranty period.
- C. The Supplier shall not be obligated to make replacements which become necessary because of ordinary wear and tear, or as a result of improper operation or maintenance, or as a result of improper work or damage by another Supplier or the Owner, or to perform any work which is normally performed by a maintenance crew during operation.
- D. In the event of multiple failures of major consequences prior to the expiration of the warranty period described above, disassemble, inspect and modify or replace, as necessary, the affected unit to prevent further occurrences. Replace all related components which may have been damaged or rendered non-serviceable as a consequence of the failure. Provide a new warranty period against defective or deficient design, workmanship, and materials equal to the original warranty period commencing on the day that the item is reassembled and placed back into operation. As used herein, multiple failure shall be interpreted to mean two or more successive failures of the same kind in the same item or failures of the same kind in two or more items. Major failures may include, but are not limited to, cracked or broken housings, piping, or vessels, excessive deflections, bent or broken shafts, broken or chipped gear teeth, premature bearing failure, excessive wear or excessive leakage around seals. Failures which are directly and clearly traceable to operator abuse, such as operations in conflict with published operating procedures or improper maintenance, such as substitution of unauthorized replacement parts, use of incorrect lubricants or chemicals, flagrant over-or under-lubrication and using maintenance procedures not conforming with published maintenance instructions, shall be exempted from the scope of the warranty period. Should multiple failures occur in a given item, disassemble, inspect, modify or replace, as necessary, and re-warrant for the original full warranty period all products of the same size and type.
- E. In the event the Supplier fails to proceed to remedy the defects upon notification within 10 days of the date of such notice, the Owner reserves the right to cause the required materials to be procured and the work to be done, as described in the Specifications, and to hold the Supplier liable for the cost and expense thereof.
- F. Notice to Supplier for repairs will be made in the form of a registered letter addressed to the Supplier at Supplier's home office.

G. Neither the foregoing paragraphs nor any provision in the Contract Documents, nor any special guarantee time limit implies any limitation of the Supplier's liability within the law of the place of construction.

PART 2 PRODUCTS (NOT USED)

PART 3 EXECUTION (NOT USED)

END OF SECTION

RECORD DOCUMENTS

PART 1 GENERAL

1.1 SUMMARY

A. Section Includes

<u>Paragraph</u>	<u>Title</u>
1.2	Quality Assurance
1.3	Recording
1.4	Record Drawings
1.5	Specifications
1.6	Submittal

B. Scope

1. The work under this Section includes, but is not necessarily limited to, the compiling, maintaining, recording and submitting of project Record Documents for the new control panels.
2. Record Documents include, but are not limited to:
 - a. Drawings;
 - b. Specifications;
 - c. Change orders and other modifications to the Contract;
 - d. Engineer field orders or written instructions, including Requests for Information (RFI) and Clarification Memorandums;
 - e. Reviewed shop drawings, product data and samples;
 - f. Test records.
3. Provide final as-built drawings of the provided control panel for each pump station. Drawings shall be specific for the respective pump station and not general or typical drawings.

1.2 QUALITY ASSURANCE

- A. Furnish qualified and experienced person, whose duty and responsibility is to maintain Record Documents.
- B. Accuracy of Records:
 1. Drawings shall reflect the actual layout, orientation, and fabrication of the control panels and components.
 2. Drawings shall be updated upon installation of the Owner installed RTU backpanel in the pump control panel. Owner will provide marked up information to use for updating the as-built panel drawings.
- C. Make entries within 24 hours after receipt of information that a change in Work has occurred.
- D. The preliminary Record Drawings shall be provided at the time of pump and panel delivery to the Owner. The final Record Drawings (updated after RTU backpanel installation) shall

be provided within 21 days following receipt of Owner mark-ups for field installation of the backpanel.

1.3 RECORDING

- A. Label each document "Project Record" in neat, large printed letters.

1.4 RECORD DRAWINGS

- A. Provide a title block on the Record Drawings indicating that the drawings are Record Drawings, the name of the company preparing the Record Drawings, and the date the Record Drawings were prepared.
- B. Legibly mark drawings to record actual fabrication, including:
 - 1. All Fabrication:
 - a. Changes of dimension and detail.
 - b. Changes made by Requests for Information (RFI), field order, work change directives, clarification memorandums or by change order.
 - c. Details not on original Drawings.
 - 2. Making Entries on Drawings:
 - a. Using an erasable colored pencil (not ink or indelible pencil, clearly describe change by graphic line and note as required.
 - 1) Color Coding:
 - a) Green when showing information deleted from Drawings.
 - b) Red when showing information added to Drawings.
 - c) Blue and circled in blue to show notes.
 - b. Date entries.
 - c. Call attention to entry by "cloud" drawn around area or areas affected.

1.5 SPECIFICATIONS

- A. Legibly mark each section to record:
 - 1. Manufacturer, trade name, catalog number, and supplier of each product and item of equipment actually installed.
 - 2. Changes made by Requests for Information (RFI), field order, clarification memorandums, or by change order.

1.6 SUBMITTAL

- A. At contract closeout, deliver Record Documents to the Engineer for the Owner.
- B. Accompany submittal with transmittal letter, in duplicate, containing:
 - 1. Date
 - 2. Project title and number
 - 3. Contractor's name and address
 - 4. Title and number of each record document
 - 5. Signature of Contractor or Contractor's authorized representative

PART 2 PRODUCTS (NOT USED)

PART 3 EXECUTION (NOT USED)

END OF SECTION

SECTION 01 78 43

SPARE PARTS

PART 1 GENERAL

1.1 SUMMARY

A. Section Includes

<u>Paragraph</u>	<u>Title</u>
1.2	Submittals
1.3	Source of Supply
1.4	Delivery, Storage, and Handling
3.1	General

B. Scope

1. The Work covered by this section includes furnishing all spare parts as identified in the individual equipment specifications.

1.2 SUBMITTALS

- A. Provide a list of all spare parts to be provided as part of the Work, including manufacturer/supplier name and contact information.

1.3 SOURCE OF SUPPLY

- A. Provide spare parts manufactured by the original equipment manufacturer.
- B. Provide maintenance materials identical to those installed.

1.4 DELIVERY, STORAGE AND HANDLING

- A. Deliver required items to the locations designated by Owner.
- B. Deliver and store items in original factory packaging or other securely packaged form.
- C. Identify, on carton or package, manufacturer's name, name of item, and part number, as applicable. Identify equipment, system, area, room no., etc. for which each item is intended.

PART 2 PRODUCTS (NOT USED)

PART 3 EXECUTION

3.1 GENERAL

- A. Furnish parts and materials in manufacturer's unopened cartons, boxes, crates, or other protective covering suitable for preventing corrosion or deterioration for the maximum length of storage which may be normally anticipated. Clearly mark and identify packaging as to their contents and storage instructions.
- B. Deliver parts and materials to the Owner at time of delivery of required equipment.
- C. Provide a letter of transmittal including the following:
 1. Date of letter and transfer of parts and materials.
 2. Contract title and sewer number.

3. Supplier's name and address.
 4. A complete inventory of the parts and material listing the applicable specification section for each.
 5. A place for the Owner to sign and signify receipt of the parts and materials.
- D. Maintain responsibility for loss or damage to parts and materials until they are received and accepted by the Owner.

END OF SECTION

SECTION 01 91 13

EQUIPMENT TESTING AND FACILITY STARTUP

PART 1 GENERAL

1.1 SUMMARY

A. Section Includes

<u>Paragraph</u>	<u>Title</u>
1.2	Definitions
1.3	Unit Responsibility
1.4	Submittals
1.5	Service
1.6	Concurrent Service
1.7	Physical Checkout
1.8	Functional Test
1.9	Test Certification
1.10	Vibration and Noise Testing
2.1	General
2.2	Documentation
2.3	System and Equipment Performance Tests
2.4	Operational Tests
3.1	Supplier's Testing and Start-up Representative(s)
3.2	Equipment Testing
3.3	Supplement

B. Scope

1. The work under this Section defines the minimum scope of services to be provided by the Supplier during equipment start-up and testing.
2. Furnish all labor, materials, tools, equipment, and services for completion, as determined by the Owner and or the Engineer, of all equipment start-up and testing to determine if the equipment is installed in accordance with the manufacturers recommendations, is capable of meeting the design intent, and product will be warranted as required.
3. Although such work may not be explicitly specifically indicated elsewhere, furnish all labor, materials, tools, equipment, and services necessary for the installation of all supplementary or miscellaneous items, appurtenances, piping, valves, electrical, instrumentation, and devices, etc. incidental to or necessary for completion of all equipment start-up and testing.
4. All equipment testing and operation may be witnessed by the Engineer and shall be performed as required to confirm that the Work has been installed properly and will operate satisfactorily under the specified conditions of service. No power is to be turned on to any piece of equipment and no equipment is to be started or tested outside the presence of the manufacturer's technical representative.

5. Verify the integrity of the Work and make any adjustments, calibrations and/or remedial measures required to prepare the Work for acceptance and performance testing.

1.2 DEFINITIONS

- A. Facility: Entire Project, or an agreed-upon acceptable portion, including its entire unit processes.
- B. Field Quality Control: Term, as used in individual specification sections, which refers to specified on-site functional and performance testing of equipment.
- C. Functional Test: Test or tests in presence of Engineer to demonstrate that installed equipment meets manufacturer's installation, calibration, and adjustment requirements and other requirements as specified.
- D. Performance Test: A test performed in presence of Engineer and Owner and after any required functional test, to demonstrate and confirm that individual equipment meets the performance requirements specified in individual specification sections.
- E. Source Quality Control: Term, as used in individual specification sections, which refers to specified testing performed on specified equipment at manufacturer's facility prior to shipment.
- F. Unit Process: As used in this section, a unit process is a portion of the facility that performs a specific process function, such as filtration, pumping, and chemical storage/feed.

1.3 UNIT RESPONSIBILITY

- A. A single manufacturer shall assume unit responsibility for all items so specified in each section. Unit responsibility shall require that all items be products of, or guaranteed by, the manufacturer. The manufacturer shall be responsible for all coordination between components and provide all submittals, installation and start-up assistance and certifications on the equipment as a unit.

1.4 SUBMITTALS

- A. Quality Control Submittals:
 1. Completed Manufacturer's Certificate of Proper Installation as required by individual specification sections. Submit prior to beginning Facility Startup procedures.
 2. Test Reports: Functional and performance testing, in format acceptable to Engineer.
 3. Written documentation, signed by Engineer, of functional and performance test for each piece of equipment tested.
 4. Certification of calibration for testing equipment, when so specified.

1.5 SERVICE

- A. Furnish the services of a competent factory representative of the equipment to be installed, for the purpose of supervising and/or inspecting the installation, placing the equipment in service and calibrating and adjusting each item of equipment. Qualification of the representative shall be appropriate to the type of equipment furnished and subject to the approval of the Engineer. Where equipment furnished has significant process complexity, furnish the services of engineering personnel knowledgeable in the process involved and the function of the equipment. Furnish these services for minimum number of days recommended by the manufacturer and approved by the Engineer.

- B. In addition to the service period, furnish the services of a competent factory representative of the manufacturer of the equipment listed above for one day during the initial operation for instructing the repair of the equipment. The initial operation period is in addition to any time required by the manufacturer's representatives to perform adjustments or accomplish performance testing. Schedule all factory representatives to be present at the same time for the purpose of coordinating the operation of all equipment.

1.6 CONCURRENT SERVICE

- A. When approved by the Engineer, periods of service on more than one item of equipment furnished by the same manufacturer may run concurrently. Each of these manufacturers shall furnish supervisory and/or inspection service for all equipment which manufacturer furnishes.

1.7 PHYSICAL CHECKOUT

- A. During this initial inspection, each piece of equipment is to be evaluated for non-dynamic, non-operational concerns. The focus shall be to confirm the readiness of a unit or system for initial operation of the equipment in a normal duty cycle for a period of 24 hours. To the maximum extent practical, the full capabilities of each piece of equipment, including remote operation, instrumented control schemes, alternate modes of operation, and emergency operation, should be available prior to physical checkout in order to facilitate and expedite the transition from physical checkout to field testing.
- B. After the physical checkout is completed, each manufacturer's technical representative and the Supplier shall certify to the Owner, in writing, and on the Manufacturer's letterhead, that the equipment is fully installed in accordance with manufacturer's instructions and operating requirements, and ready to be tested in an operating mode without violation of or voiding any aspect or detail of the manufacturer's warranty.

1.8 FUNCTIONAL TEST

- A. Perform a functional test on each piece of equipment. The test shall consist of operation of the equipment on a normal duty cycle for a sufficient period of time to determine satisfactory operation (24 hours minimum). To the maximum extent practical, exercise the full capabilities of all equipment including remote operation, instrumented control schemes, alternate modes of operation and emergency operation. Functional test will not be deemed satisfactorily completed until all local and remote functionality and control has been demonstrated. Satisfactory completion of the Functional Test requires installation of all permanent wiring, terminations, control systems and devices.

1.9 TEST CERTIFICATION

- A. After the functional test is completed, each manufacturer shall certify to the Owner, in writing, that the equipment is fully operational and capable of meeting operating requirements.
- B. Certification of start-up and full testing shall be performed by the manufacturer using the services of an authorized representative trained in this type service. Written certification shall be filed with the Engineer on the manufacturer's stationary. Written certification shall indicate that tests were made in accordance with the manufacturer's recommendations, that the test and start-up operation has been satisfactory and that the equipment is fully operational under design requirements.
- C. References in various equipment sections to the terms "factory representative" or "field representative" shall mean an employee of the manufacturer of the equipment who is completely knowledgeable of the construction, installation, operation and maintenance of the equipment. A sales representative does not qualify. Any field or factory representative

not an active employee of the manufacturer must provide documentation from the manufacturer stating that the individual, by name, has been formally trained in the installation, operation and maintenance of the equipment and is authorized to make the required certification or perform the required services.

1.10 VIBRATION AND NOISE TESTING

- A. Conduct all vibration and noise testing in accordance with the requirements of Section 01 60 00. Satisfactory completion of the Functional Test requires satisfactory completion and reporting of vibration and noise testing.

PART 2 PRODUCTS

2.1 GENERAL

- A. Prepare test plans and documentation plans as specified in the following paragraphs. The Engineer will not witness any test work for the purpose of acceptance until all test documentation and calibration plans and the specified system or equipment test plans have been submitted and accepted.

2.2 DOCUMENTATION

A. Documentation Plans

1. Develop a records keeping system to document compliance with the requirements of this Section. Include identification (by make, manufacturer, model, and serial number) of all test equipment, date of original calibration, subsequent calibrations, calibration method, and test laboratory in calibration documentation.
2. Equipment and system documentation shall include date of test, equipment number or system name, nature of test, test objectives, test results, test instruments employed for the test and signature spaces for the Engineer's witness and the Supplier's quality assurance manager. Establish a separate file for each system and item of equipment. Include the following information as a minimum in these files:
 - a. Factory performance tests
 - b. Field calibration tests
 - c. Field pressure tests
 - d. Field performance tests
 - e. Field operational tests
3. Samples showing the format and level of detail required for the documentation forms are included at the end of this section. The Supplier is advised that these are samples only and are not specific to this project nor to any item of equipment or system to be installed under this contract. Develop test documentation forms specific to each item of equipment and system installed under this contract. Produce acceptable documentation forms for all systems and items of equipment for review by the Engineer as a condition precedent to the Supplier's receipt of progress payments in excess of 50 percent of the contract amount. Once the Engineer has reviewed and taken no exception to the forms proposed by the Supplier, produce sufficient forms to provide documentation of all testing work to be conducted as a part of this contract.

2.3 SYSTEM AND EQUIPMENT PERFORMANCE TESTS

- A. Test each item of mechanical, electrical, and instrumentation equipment provided under this contract to demonstrate compliance with the performance requirements of these specifications.

- B. Test each electrical, instrumentation, and mechanical system installed or modified under this contract in accordance with the requirements of these specifications.

2.4 OPERATIONAL TESTS

- A. Once all equipment and systems have been tested individually, fill all systems with the intended process fluids. Wastewater-derived process systems shall be filled with water. After filling operations have been completed, operate all systems for a continuous period of not less than three days, simulating actual operating conditions to the greatest extent possible. Install temporary connections, bulkheads and make other provisions to recirculate process fluids or otherwise simulate anticipated operating conditions. During the operational testing period, the Supplier's or manufacturer's field representative shall monitor the characteristics of each machine and system and report any unusual conditions to the Engineer.

PART 3 EXECUTION

3.1 SUPPLIER'S TESTING AND STARTUP REPRESENTATIVE(S)

- A. Designate and furnish Supplier's personnel dedicated solely to coordinate and expedite testing and facility startup.
- B. Make the personnel available at all times during the testing and the facility startup and performance evaluation period.

3.2 EQUIPMENT TESTING

A. Preparation

1. General:

- a. Furnish qualified manufacturer's representatives, when required by individual specification sections, to assist in testing.
- b. Furnish related operating and maintenance manuals, and have on hand necessary testing devices, spare parts, and special tools before testing any unit or system.
- c. Obtain from equipment manufacturer's representative the Manufacturer's Certificate of Proper Installation Form, when required by individual specification sections.
- d. Provide written documentation, on Supplier's or manufacturer's form, of functional and performance test results for each piece of equipment tested. Provide space on form for Engineer's signature that testing is complete.

2. Cleaning and Checking: Prior to beginning functional testing:

- a. Lubricate equipment in accordance with manufacturer's instructions.
- b. Turn rotating equipment by hand when possible to confirm that equipment is not bound.
- c. Check power supply to electric-powered equipment for correct voltage.

3. Ready-to-test determination will be by Engineer and Owner based at least on the following:

- a. Notification by Supplier of equipment readiness for testing.
- b. Acceptable testing plan.
- c. Acceptable Final Operation and Maintenance Manuals including electronic copies.
- d. Receipt of Manufacturer's Certificate of Proper Installation, if so specified.

- e. Availability and acceptability of manufacturer's representative, when specified, to assist in testing of respective equipment.
- f. Satisfactory fulfillment of other specified manufacturers' responsibilities.
- g. Delivery of all spare parts and special tools.

B. Functional Testing

1. Conduct as specified in individual specification sections.
2. Notify manufacturer's representative in writing at least 21 days prior to scheduled date of testing.
3. If, in Engineer's opinion, equipment meets the functional requirements specified, such equipment will be accepted for purposes of advancing to performance testing phase, if so required by the individual Specification Sections.

C. Performance Testing

1. Conduct as specified in individual specification sections.
2. Performance testing shall not commence until equipment has been approved by Engineer as having satisfied functional test requirements specified.
3. Follow approved testing plan and detailed procedures specified.
4. Source and type of fluid, gas, or solid for testing shall be as specified.
5. Unless otherwise indicated, furnish all labor, materials, and supplies for conducting the test and taking all samples and performance measurements.
6. Prepare performance test report summarizing test method and results.
7. If, in Engineer's opinion, equipment meets performance requirements specified, such equipment will be accepted as to conforming to Contract requirements.

3.3 SUPPLEMENT

A. Supplements listed below, following "END OF SECTION," are a part of this Specification:

1. Equipment Start-up and Testing Log
2. Equipment Start-up and Testing Report
3. Manufacturer's Certificate of Compliance
4. Manufacturer's Certificate of Proper Installation
5. Equipment Test Report Form

END OF SECTION

INSERT PROJECT NAME HERE

EQUIPMENT START-UP/TESTING REPORT

DATE: _____

CONTRACT NUMBER AND TITLE: _____

CONSTRUCTION MANAGER: _____

MANUFACTURER: _____

EQUIP ITEM/TAG NO: _____

SYSTEM: _____

FACILITY NAME: _____ FACILITY NO.: _____ STRUCTURE NO.: _____

DCS LOOP: _____ POWER SOURCE: _____

CONSTRUCTION MANAGER STARTUP

TYPED NAME: _____

SIGNATURE: _____

MANUFACTURER REPRESENTATIVE:

TYPED NAME: _____

SIGNATURE: _____

ENGINEER REPRESENTATIVE:

TYPED NAME: _____

SIGNATURE: _____

Unit Process Description: (Include description of all equipment and devices)

Start-up Procedure: (Describe procedure for sequential start-up & evaluation, including valves to be opened/closed, order of equipment start-up, etc.)

Start-up Requirements: (Water, power, chemicals, etc.)

Test Procedures:

Passed

<i>INSERT PROJECT NAME HERE</i>	<i>EQUIPMENT START-UP/TESTING REPORT</i>
Evaluation Comments:	
Contractor Certification: I certify the Unit Process is capable of performing its intended function(s), including fully automatic operation.	
CONTRACTOR NAME:	
START-UP REPRESENTATIVE: _____	DATE: _____
Authorized Signature	

Manufacturer's Certificate of Compliance

Project: INSERT PROJECT NAME HERE	Project No.: INSERT PROJ. NO. HERE
Owner: Gwinnett County Department of Water Resources	
Equipment/System:	Spec. Section:
Equipment Serial No.:	Equipment Tag No.:
Manufacturer:	

Comments:

I hereby certify the above referenced product, material, or service called for by the Contract for the named project will be furnished in accordance with all applicable requirements. I further certify the product, material, or service is of the quality specified and conforms in all respects with the contract requirements, and is in the quantity shown.

Date of Execution: _____

Manufacturer's Authorized Representative: _____
(Print Name)

Manufacturer's Authorized Representative: _____
(Signature)

Manufacturer's Certificate of Proper Installation

To Engineer: INSERT NAME OF ENGINEER HERE	
Project: INSERT PROJECT NAME HERE	Project No.: INSERT PROJ. NO. HERE
Owner: Gwinnett County Department of Water Resources	
Equipment/System:	Spec. Section:
Equipment Serial No.:	Equipment Tag No.:
Manufacturer:	

I hereby certify the above-referenced equipment/system has been: (check Applicable)

- Installed in accordance with Manufacturer's recommendations.
- Inspected, adjusted, properly aligned and is free from undue stress from piping or anchor bolts.
- Serviced with proper initial lubricants.
- Electrical and mechanical connections are complete and meet quality and safety standards.
- All Applicable human and/or equipment safety devices have been properly installed.
- The equipment is ready to operate under full load conditions.

Comments:
I, the undersigned Manufacturer's Representative, hereby certify that I am (i) a duly authorized representative of the manufacturer, (ii) empowered by the manufacturer to inspect, approve, and operate this equipment, and (iii) authorized to make recommendations required to assure the equipment furnished by the manufacturer is complete and operational. I further certify all information contained herein is true and accurate.
Date:
Manufacturer:
By Manufacturer's Authorized Representative: _____ Signature

EQUIPMENT TEST REPORT FORM

NOTE: This example equipment test report is provided for the benefit of the Contractor and is not specific to any piece of equipment to be installed as a part of this project. The example is furnished as a means of illustrating the level of detail required for the preparation of equipment test report forms for this project.

CITY OF SAMPLE

**EXAMPLE WASTEWATER TREATMENT PLANT
STAGE IV EXPANSION PROJECT**

ABC Construction Company, Inc., General Contractor
XYZ Engineering, Inc., Engineer

EQUIPMENT TEST REPORT

Equipment Name: Submersible Pump 2
 Equipment Number: P25202
 Specification Ref: 43 21 39
 Location: Wet Well

	Contractor		Engineer	
	Verified	Date	Verified	Date
PREOPERATIONAL CHECKLIST				
<u>Mechanical</u>				
Lubrication				
Alignment				
Anchor bolts				
Seal water system operational				
Equipment rotates freely				
Safety guards				
Valves operational				
Hopper purge systems operational				
Sedimentation tank/hopper clean				
O&M manual information complete				
Manufacturer's installation certificate complete				
<u>Electrical</u> (circuit ring-out and high-pot tests)				
Circuits:				
Power to MCC 5				
Control to HOA				

	Contractor		Engineer	
	Verified	Date	Verified	Date
Indicators at MCC:				
Red (running)				
Green (power)				
Amber (auto)				
Indicators at local control panel				
Wiring labels complete				
Nameplates:				
MCC				
Control station				
Control panel				
Equipment bumped for rotation				
<u>Piping Systems</u>				
Cleaned and flushed:				
Suction				
Discharge				
Pressure tests				
Temporary piping screens in place				
<u>Instrumentation and Controls</u>				
Flowmeter FE2502F calibration				
Calibration Report No.				
Flow recorder FR2502G calibrated against transmitter				
VFD speed indicator calibrated against independent reference				
Discharge overpressure shutdown switch calibration				
Simulate discharge overpressure Shutdown				
FUNCTIONAL TESTS				
<u>Mechanical</u>				
Motor operation temperature satisfactory				
Pump operating temperature satisfactory				
Unusual noise, etc?				
Pump operation: 75 gpm/50 psig				
Measurement:				
Flow:				
Pressure:		Test gage number:		
Alignment hot				
Dowelled in				
Remarks:				

	Contractor		Construction Manager	
	Verified	Date	Verified	Date
<u>Electrical</u>				
Local switch function:				
Runs in <i>HAND</i>				
No control power in <i>OFF</i>				
Timer control in <i>AUTO</i>				
Overpressure protection switch PS2502C functional in both <i>HAND</i> and <i>AUTO</i>				
Overpressure protection switch PS2502C set at 75 psig				
PLC 2500 set at 24-hour cycle, 25 min <i>ON</i>				
OPERATIONAL TEST				
48-hour continuous test. Pump cycles as specified, indicators functional, controls functional, pump maintains capacity, overpressure protection remains functional, hour meter functional				

RECOMMENDED FOR BENEFICIAL OCCUPANCY

Engineer _____ Date _____

ACCEPTED FOR BENEFICIAL OCCUPANCY

Owner's Representative _____ Date _____

SECTION 09 91 00

PAINTING

PART 1 GENERAL

1.1 SUMMARY

A. Section Includes

<u>Paragraph</u>	<u>Title</u>
1.2	References
1.3	Administrative Requirements
1.4	Submittals
1.5	Quality Assurance
1.6	Delivery, Storage, and Handling
1.7	Field Conditions
1.8	Testing Equipment
1.9	Warranty
2.1	Manufacturers
2.2	Paint Materials
2.3	Paint Schedule
2.4	Abrasive Materials
2.5	Accessories
2.6	Mixing
2.7	Shop Finishes
3.1	Examination
3.2	Protection of Surfaces Not Scheduled to be Coated
3.3	Surface Preparation of Steel
3.4	Surface Preparation of Ductile or Cast Iron
3.5	Application
3.6	Repair
3.7	Field Quality Control
3.8	Cleaning
3.9	Protection of Coating Systems
3.10	Attachments

B. Scope

1. In general, work included under this section includes the surface preparation, shop priming, field priming, and/or field painting of all exposed items and surfaces throughout the project, unless otherwise indicated.
2. Paint all exposed items and surfaces using the appropriate paint system as specified herein. Coating system schedules and finish schedules may be provided herein and/or

on the Drawings, which identify specific paint systems and paint colors to be used on specific items and surfaces. However, these schedules do not necessarily cover all items to be painted. Where the selection of a specific painting system for a particular application is not clear, it is the Contractor's responsibility to request clarification from the Engineer.

3. Surface preparation, priming, and coats of paint specified are in addition to shop priming and surface pretreatment specified in other sections, unless otherwise indicated.
4. Paint all exposed surfaces except where the natural finish of the material is obviously intended to be the finished surface or if the surface is specifically noted not to be painted.
5. In general, items to be painted include:
 - a. All exposed exterior surfaces including:
 - 1) Concrete block.
 - 2) Equipment supports.
 - 3) Pipe, valves, fittings, hydrants, and appurtenances.
 - 4) Ductwork and appurtenances.
 - 5) Non-galvanized conduit and appurtenances.
 - 6) Interior and exterior surfaces of ferrous metal tankage.
 - 7) Ferrous metals.
 - 8) All factory primed steel doors and equipment.
 - 9) Exposed untreated wood.
 - 10) All other surfaces subject to corrosion.
 - b. All exposed interior surfaces including:
 - 1) All wall surfaces in all spaces unless specifically noted not to be painted.
 - 2) All columns, equipment pads, pipe supports, and appurtenances.
 - 3) Pipe, valves, fittings, hydrants, and appurtenances.
 - 4) Ductwork and appurtenances.
 - 5) All electrical conduit unless specifically noted not to be painted.
 - 6) All hangers and supports for overhead items.
 - 7) Ferrous metals.
 - 8) All factory primed steel doors and equipment.
 - 9) Exposed untreated wood.
 - 10) All other surfaces subject to corrosion.
 - c. Equipment that does not have an approved final coat or does not have the appropriate finished color as directed by the Engineer.
 - d. All equipment that has been damaged by the existing construction as directed by the Engineer.
 - e. All existing or new items and surfaces damaged by construction as directed by the Engineer.
6. In general, items NOT to be painted include:

- a. Items with Engineer approved factory finish.
- b. Electrical equipment unless specifically noted.
- c. Surfaces hidden from view including piping, conduit, ducts, and insulation. Note, the manufacturer's standard coatings, if any, may remain.
- d. Stainless steel surfaces except piping or tubing.
- e. Aluminum surfaces except:
 - 1) Where specifically noted to be painted.
 - 2) Where embedded in or in contact with concrete.
 - 3) Where in contact with dissimilar metals.
 - 4) Piping or tubing.
- f. Fiberglass surfaces except piping and piping appurtenances.
- g. Interior of pipe, ductwork, and conduits.
- h. Moving parts of mechanical and electrical units where painting would interfere with the operation of the unit.
- i. Code labels and equipment identification and rating plates.
- j. Exterior concrete or pre-cast concrete surfaces.
- k. Galvanized metal surfaces except interior conduit.
- l. Face brick, ceramic tile, plastic laminate.
- m. Concealed deck except where specifically specified to be painted.
- n. Pre-finished metal.
- o. Interior and exterior of concrete basins, vaults, and tanks unless noted otherwise.

1.2 REFERENCES

A. Abbreviations and Acronyms

- 1. FRP: Fiberglass Reinforced Plastic.
- 2. HCl: Hydrochloric Acid.
- 3. MDFT: Minimum Dry Film Thickness, mils.
- 4. MDFTPC: Minimum Dry Film Thickness per Coat, mils.
- 5. Mil: Thousandth of an inch.
- 6. PDS: Product Data Sheet.
- 7. PSDS: Paint System Data Sheet.
- 8. SFPG: Square Feet per Gallon.
- 9. SFPGPC: Square Feet per Gallon per Coat.
- 10. SP: Surface Preparation.

B. Definitions

- 1. Definitions of Painting Terms: ASTM D16, unless otherwise specified.
- 2. Coverage: Total minimum dry film thickness in mils or square feet per gallon.
- 3. Dry Film Thickness (DFT): Thickness of a coat of paint in fully cured state measured in mils (1/1000 inch).

C. Reference Standards

1. American Water Works Association (AWWA):
 - a. C116, Protective Fusion-Bonded Epoxy Coatings for the Interior and Exterior Surfaces of Ductile-Iron and Gray-Iron Fittings.
 - b. C203, Coal-Tar Protective Coatings and Linings for Steel Water Pipelines – Enamel and Tape – Hot Applied.
 - c. C209, Cold-Applied Tape Coatings for Exterior of Special Sections, Connections, and Fittings for Steel Water Pipelines.
 - d. C213, Fusion-Bonded Epoxy Coating for Interior and Exterior of Steel Water Pipelines.
 - e. C214, Tape Coating Systems for the Exterior of Steel Water Pipelines.
2. Environmental Protection Agency (EPA).
3. NACE International (NACE): RP0188, Discontinuity (Holiday) Testing of New Protective Coatings on Conductive Substrates.
4. Occupational Safety and Health Act (OSHA).
5. The Society for Protective Coatings (SSPC):
 - a. PA 2, Measurement of Dry Coating Thickness with Magnetic Gages.
 - b. PA 3, Guide to Safety in Paint Applications.
 - c. SP 1, Solvent Cleaning.
 - d. SP 2, Hand Tool Cleaning.
 - e. SP 3, Power Tool Cleaning.
 - f. SP 5, White Metal Blast Cleaning.
 - g. SP 6, Commercial Blast Cleaning.
 - h. SP 7, Joint Surface Preparation Standard Brush-off Blast Cleaning.
 - i. SP 10, Near-White Blast Cleaning.
 - j. SP 11, Power Tool Cleaning to Bare Metal.
 - k. SP 12, Surface Preparation and Cleaning of Metals Waterjetting Prior to Recoating.
 - l. SP 13, Surface Preparation of Concrete.
 - m. Guide 15, Field Methods for Retrieval and Analysis of Soluble Salts on Steel and Other Nonporous Substrates.

1.3 ADMINISTRATIVE REQUIREMENTS

A. Pre-application Meetings

1. Convene a pre-application meeting two weeks before start of application of coating systems. Attendance of parties directly affecting work of this section, including Contractor, Engineer, Applicator, Manufacturer's Representative and Independent Testing and Inspection Agencies with NACE III Inspector, is required. The meeting shall cover, but not be limited to, the following:
 - a. Environmental requirements.
 - b. Protection of surfaces not scheduled to be coated.
 - c. Surface preparation.
 - d. Application.

- e. Repair.
- f. Field quality control.
- g. Cleaning.
- h. Protection of coating systems.
- i. One-year inspection.
- j. Coordination with other work.

1.4 SUBMITTALS

A. Action Submittals/Informational Submittals

1. Product Data

- a. For each product, furnish a Product Data Sheet (PDS), the manufacturer's technical data sheets, and paint colors available (where applicable). The PDS form is appended to the end of this section.
- b. For each paint system, furnish a Paint System Data Sheet (PSDS). The PSDS form is appended to the end of this section.
- c. Technical and performance information that demonstrates compliance with Specifications.
- d. Furnish copies of paint system submittals to the coating applicator.
- e. Indiscriminate submittal of only manufacturer's literature is not acceptable.
- f. Detailed chemical and gradation analysis for each proposed abrasive material.

2. Samples

- a. Proposed Abrasive Materials: Minimum 5-pound sample for each type.
- b. Reference Panel:
 - 1) Surface Preparation:
 - a) Prior to start of surface preparation, furnish a 4-inch by 4-inch steel panel for each grade of sandblast specified herein, prepared to specified requirements.
 - b) Provide panel representative of the steel used; prevent deterioration of surface quality.
 - c) Panel to be reference source for inspection upon approval of Engineer.
 - 2) Paint:
 - a) Unless otherwise specified, before painting work is started, prepare minimum 8-inch by 10-inch sample with type of paint and application specified on similar substrate to which paint is to be applied.
 - b) Furnish additional samples as required until colors, finish, and textures are approved.
 - c) Approved samples to be the quality standard for final finishes.

3. Certificates

- a. Coating Manufacturer's Certificate of Compliance, in accordance with Section 01 43 33 – Manufacturer Services.
- b. Factory Applied Coatings: Manufacturer's certification stating factory applied coating system meets or exceeds requirements specified.

- c. Manufacturer's written verification that submitted material is suitable for the intended use.
 - d. If the manufacturer of finish coating differs from that of shop primer, provide finish coating manufacturer's written confirmation that materials are compatible.
4. Manufacturer's Instructions
 - a. Manufacturer's written instructions and special details for applying each type of paint.
 5. Warranty Documentation
 - a. Submit a complete description of the warranty to be provided.
 6. Special Procedure Submittals
 - a. Paint Schedule:
 - 1) Submit a schedule of all items (structures, equipment, pipe, etc.) to be painted prior to beginning painting operations. Schedule shall include, but not be limited to, items to be painted, surface preparation, paint system, and color. Submit the schedule to the Engineer for approval at which time the Engineer will select the colors to be used that are not specified herein or on the Drawings.
 7. Qualification Statements
 - a. Manufacturer's Qualifications:
 - 1) List of references demonstrating successful performance on similar projects of the product being provided.
 - b. Applicator's Qualifications:
 - 1) List of references substantiating experience. Include size of project, timeframe when work was completed, and type of product used.
 - 2) Documentation from manufacturer stating applicator is a certified for application of the specific product.

1.5 QUALITY ASSURANCE

A. Regulatory Requirements

1. Meet federal, state, and local requirements limiting the emission of volatile organic compounds.
2. Perform surface preparation and painting in accordance with recommendations of the following:
 - a. Paint manufacturer's instructions.
 - b. SSPC PA 3, Guide to Safety in Paint Applications.
 - c. Federal, state, and local agencies having jurisdiction.

B. Qualifications

1. Manufacturers
 - a. Specialize in manufacture of coatings with a minimum of 10 years successful experience.
 - b. Able to demonstrate successful performance on comparable projects.
 - c. Single Source Responsibility

- 1) Coatings and coating application accessories shall be products of a single manufacturer.
2. Applicators
 - a. Experienced in application of specified coatings for a minimum of 5 years on projects of similar size and complexity to this work.
 - b. Applicator's Personnel
 - 1) Employ persons trained for surface preparation and application of specified coatings.
- C. Manufacturer's Representative During Painting Operations
 1. An authorized Manufacturer's representative, with qualifications as stated herein, shall be present at the start-up and weekly during painting operations. Such representative shall inspect, instruct, and observe the Contractor's and Applicator's work and shall, at the completion of work, certify in writing to the Engineer that the Manufacturer's application recommendations have been adhered to. The cost of this work shall be borne by the Contractor.
 2. Manufacturer's technical representative or authorized inspector shall be currently certified by NACE (minimum NACE III certification) or SSPC.
- D. Testing Agencies
 1. The Owner may employ coating inspectors and materials testing agencies to examine and test installation.
 2. Repair or replace defective work discovered at no cost to the Owner.
- E. Mock-ups
 1. Before proceeding with Work under this section, finish one complete space or item of each color scheme required showing selected colors, finish texture, materials, quality of work, and special details.
 2. After Engineer approval, sample spaces or items will be the quality standard for similar work throughout the Project.
- F. Inspections
 1. All coating products to be installed under this Contract may be inspected at the manufacturer's facilities or plant for compliance with these specifications by an independent testing laboratory provided by the Owner. Require the manufacturer's cooperation in these inspections. Cost for facility or plant inspections to be paid for by the Owner.
 2. Inspections of the coating products and materials may also be made by representatives of the Owner after delivery.
 3. The products and materials shall be subject to rejection at any time on account of failure to meet any of the Specification requirements, even though samples may have been accepted as satisfactory at the place of manufacturing.
 4. Materials rejected after delivery shall be marked for identification and removed from the site.

1.6 DELIVERY, STORAGE, AND HANDLING

A. Delivery and Acceptance Requirements

1. Deliver materials to site in manufacturer's original, unopened containers and packaging, with labels clearly identifying:

- a. Coating or material name.
- b. Manufacturer.
- c. Color name and number.
- d. Batch or lot number.
- e. Date of manufacture.
- f. Mixing and thinning instructions.

B. Storage and Handling Requirements

1. Store materials in a clean dry area and within temperature range in accordance with Manufacturer's instructions.
2. Keep containers sealed until ready for use.
3. Do not use materials beyond Manufacturer's shelf life limits.
4. Protect materials during handling and application to prevent damage or contamination.

1.7 FIELD CONDITIONS

A. Environmental Requirements

1. Weather

a. Air and Surface Temperatures

- 1) Prepare surfaces and apply and cure coatings within air and surface temperature range in accordance with Manufacturer's instructions.

b. Surface Temperature

- 1) Minimum of 5°F (3°C) above dew point.

c. Relative Humidity

- 1) Prepare surfaces and apply and cure coatings within relative humidity range in accordance with Manufacturer's instructions.

d. Precipitation

- 1) Do not prepare surfaces or apply coatings in rain, snow, fog, or mist.

e. Wind

- 1) Do not spray coatings if wind velocity is above manufacturer's limit. Contractor shall be solely responsible for costs associated with restoration of any areas, equipment, structures, or surfaces impacted by overspray or splatter resulting from the application of coatings during windy conditions.

2. Ventilation

- a. Provide ventilation during coating evaporation stage in confined or enclosed areas in accordance with AWWA D102.

3. Dust and Contaminants

- a. Schedule coating work to avoid excessive dust and airborne contaminants.
- b. Protect work areas from excessive dust and airborne contaminants during coating application and curing.

1.8 TESTING EQUIPMENT

- A. Furnish and make available to the Engineer the following items of testing equipment for use in determining if requirements of this section are being satisfied. Make available the

specified items of equipment for the Engineer's use at all times when field painting or surface preparation is in progress.

1. Wet film gauge.
2. Surface thermometer.
3. Keane-Tator surface profile comparator.
4. Set of National Association of Corrosion Engineers (NACE) visual standards.
5. Holiday (pin hole) detectors (low and high voltage).
6. Sling-psychrometer.
7. Magnetic dry film gauge.

1.9 WARRANTY

A. Manufacturer Warranty

1. Warrant all paint and coatings installed for a period of two years from the date of final acceptance. During this period, repair or replace all defects discovered in the coating, as determined by the Owner or Owner's representative at no cost to the Owner.
2. Properly prepare the surface for paint and coating prior to the installation of the systems, including stopping all leaks, patching voids, protecting or removing and handling all mechanical equipment such as valves and valve assemblies and weirs, cleaning surfaces, removing rubble, etc.

PART 2 PRODUCTS

2.1 MANUFACTURERS

A. Approved manufacturers include:

1. Tnemec.
2. Induron.
3. Carboline.
4. Engineer approved equal.

2.2 PAINT MATERIALS

A. General

1. Manufacturer's highest quality products suitable for intended service.
2. Compatibility: Only compatible materials from a single manufacturer shall be used in the Work. Particular attention shall be directed to compatibility of primers and finish coats.
3. Thinners, Cleaners, Driers, and Other Additives: As recommended by coating manufacturer.

B. Products

1. Acrylic Emulsion
2. Acrylic Epoxy
3. Aliphatic Acrylic Polyurethane
4. Ceramic-Modified Waterborne Aliphatic Polyurethane

5. Cycloaliphatic Amine Epoxy
6. Epoxy Modified Cementitious Mortar
7. Modified Alkyd Primer
8. Modified Novolac Polyamine Epoxy
9. Modified Polyamine Ceramic Epoxy
10. Modified Polyamine Epoxy
11. Modified Silicone Resin
12. Modified Waterborne Acrylate
13. Polyamide Epoxy
14. Polyamide Epoxy-Coal Tar
15. Polyamidoamine Epoxy
16. Polyamine Novolac Epoxy
17. Quartz-Filled Modified Polyamine Epoxy
18. Waterborne Acrylic Epoxy
19. Waterborne Cementitious Acrylic Masonry Filler
20. Waterborne Modified Polyamine Epoxy
21. Zinc Silicone Primer

2.3 PAINTING SCHEDULE

A. General:

1. Manufacturer's highest quality products suitable for intended service.
2. Compatibility: Only compatible materials from a single manufacturer shall be used in the Work. Particular attention shall be directed to compatibility of primers and finish coats.
3. Thinners, Cleaners, Driers, and Other Additives: As recommended by coating manufacturer.

B. The Painting Schedule presented below summarizes the painting systems to be applied to the various surfaces.

C. Exposure terms refer to the environmental conditions to which different surfaces may be exposed. A surface may exist in more than one exposure, e.g. an exterior wall can be categorized not only as "Exposed", but also as "Buried", where the exposure is below the grade line.

D. In addition to the major items listed in the Painting Schedule, the Contractor shall paint safety warnings and notices as outlined in these specifications.

PAINTING SCHEDULE						
Exposure	System Type	Surface Prep	Prime Coat	Intermediate Coat	Finish Coat	Total DFT
STEEL - STRUCTURAL, TANKS, PIPE, AND EQUIP – pump supports, anchorage, misc. steel.						
Exterior Exposed (outside structure)	Epoxy/Polyurethane	SSPC-SP 6	Polyamidoamine Epoxy, 3 to 5 mils DFT		Aliphatic Acrylic Polyurethane, 3 to 5 mils DFT	6 to 10 mils
Interior Exposed (inside structure)	Epoxy	SSPC-SP 6	Polyamidoamine Epoxy, 3 to 5 mils DFT		Polyamidoamine Epoxy, 4 to 6 mils DFT	7 to 11 mils
Immersion (non-potable water)	Epoxy	SSPC-SP 10	Polyamidoamine Epoxy, 3 to 5 mils DFT		Cycloaliphatic Amine Epoxy, 8 to 10 mils DFT	11 to 15 mils
Severe Atmosphere	Modified Polyamine Epoxy	SSPC-SP 5 w/ min. 3 mil profile	Modified Polyamine Epoxy, 15 to 20 mils DFT		Modified Polyamine Epoxy, 15 to 20 mils DFT	30 to 40 mils
High Temperature	High Heat Silicone	SSPC-SP 10	Zinc Silicone Primer, 2 to 3 mils DFT		Modified Silicone Resin, 2 to 3 mils DFT	4 to 6 mils
FACTORY PRIMED OR GALVANIZED STEEL – doors, frames, exposed metal deck on ceilings, miscellaneous equipment						
Exterior Exposed	Epoxy/Polyurethane	Clean and Dry	Factory Primed	Polyamide Epoxy, 3 to 5 mils DFT	Aliphatic Acrylic Polyurethane, 2 to 3 mils DFT	4 to 6 mils
Interior Exposed	Epoxy	Clean and Dry	Factory Primed	Polyamide Epoxy, 2 to 3 mils DFT	Polyamidoamine Epoxy, 2 to 3 mils DFT	4 to 6 mils
Immersion (inside wet well)	Epoxy	SSPC-SP 1, followed by abrasive blast	Polyamide Epoxy, 3 to 5 mils	Polyamide Epoxy, 4 to 6 mils	Polyamide Epoxy, 4 to 6 mils DFT	11 to 16 mils
DUCTILE OR CAST IRON - PIPE, PUMPS, AND VALVES						
Interior Exposed (Inside building.)	Epoxy	Per Mfgr. specs	Polyamide Epoxy, 3 to 5 mils DFT		Polyamide Epoxy, 4 to 6 mils DFT	7 to 11 mils
Exterior Exposed	Epoxy/Polyurethane	Per Mfgr. specs	Polyamide Epoxy, 3 to 5 mils DFT	Polyamide Epoxy, 4 to 6 mils DFT	Aliphatic Acrylic Polyurethane, 2 to 3 mils DFT	9 to 14 mils
Immersion (Inside tanks, vaults, buildings)	Ceramic Epoxy	Per Mfgr. specs			Modified Polyamine Ceramic Epoxy, 40 to 60 mils DFT	40 to 60 mils
Severe Atmosphere Interior & Exterior DIP, refer to Section 33 11 13.05	Ceramic Epoxy	Per Mfgr. specs			Modified Polyamine Ceramic Epoxy, 40 to 60 mils DFT	40 to 60 mils
High Temperature	High Heat Silicone	SSPC-SP 10	Zinc Silicone Primer, 2 to 3 mils DFT		Modified Silicone Resin, 2 to 3 mils DFT	4 to 6 mils

2.4 ABRASIVE MATERIALS

- A. Select abrasive type and size to produce surface profile that meets coating manufacturer's recommendations for specific primer and coating system to be applied.

2.5 ACCESSORIES

- A. Coating Application Accessories

1. Accessories required for application of specified coatings are to be used in accordance with manufacturer's instructions, including thinners.
2. Products and accessories used in the preparation and application of the coating systems shall be manufactured by, or approved for use by, the coating manufacturer.

2.6 MIXING

A. Multiple-Component Coatings:

1. Prepare using each component as packaged by paint manufacturer.
2. No partial batches will be permitted.
3. Do not use multiple-component coatings that have been mixed beyond their pot life.
4. Furnish small quantity kits for touchup painting, for painting other small areas, and for preparation of mockups.
5. Mix only components specified and furnished by paint manufacturer.
6. Do not intermix additional components for reasons of color or otherwise, even within the same generic type of coating.

B. Colors: Formulate paints with colorants free of lead, lead compounds, or other materials that may be affected by presence of hydrogen sulfide or other gas likely to be present at the Site.

2.7 SHOP FINISHES

A. Surface Preparation: Provide Engineer minimum 7 days' advanced notice to start of shop surface preparation work and coating application work.

B. Shop Coating Requirements:

1. When required by equipment specifications, equipment shall be primed and finish coated in shop by manufacturer and touched up in field with identical material after installation to the satisfaction of the Engineer.
2. Where manufacturer's standard coating is not suitable for intended service condition, Engineer may approve use of a tie-coat to be used between manufacturer's standard coating and specified field finish. In such cases, provide a surface tolerant epoxy tie-coat as recommended by manufacturer of specified field finish coat. Coordinate details of equipment manufacturer's standard coating with field coating manufacturer.

C. Pipe:

1. Ductile Iron Pipe:

- a. Use SSPC standards as a guide for desired prepared surface.
- b. Follow recommendations of pipe and coating manufacturers for means and methods to achieve SSPC-equivalent surface.
- c. The surface preparation and application of the primer shall be performed by pipe manufacturer.
- d. For high performance (epoxy) coatings, follow additional recommendations of pipe and coating manufacturers.
- e. Prior to blast cleaning, grind smooth surface imperfection, including, but not limited to delaminating metal or oxide layers.
- f. For conventional (alkyd) coatings, clean asphalt varnish supplied on pipe and apply one full coat of a tar stop before two full coats of the color coats specified.

PART 3 EXECUTION

3.1 EXAMINATION

- A. Examine areas and conditions under which coating systems are to be applied. Notify Engineer of areas or conditions not acceptable. Do not begin surface preparation or application until unacceptable areas or conditions have been corrected.
- B. Surface Preparation Verification: Inspect and provide substrate surfaces prepared in accordance with these Specifications and printed directions and recommendations of paint manufacturer whose product is to be applied. Follow the more stringent requirements.
- C. Factory Finished Items: Schedule inspection with Engineer before repairing damaged factory-finished items delivered to the Site.

3.2 PROTECTION OF SURFACES NOT SCHEDULED TO BE COATED

- A. Protect surrounding areas and surfaces not scheduled to be coated from damage during surface preparation and application of coatings.
- B. Remove, mask, or otherwise protect hardware, lighting fixtures, switchplates, aluminum surfaces, machined surfaces, couplings, shafts, bearings, nameplates on machinery, and other surfaces not specified elsewhere to be painted.
- C. Provide drop cloths to prevent paint materials from falling on or marring adjacent surfaces.
- D. Protect working parts of mechanical and electrical equipment from damage during surface preparation and painting process.
- E. Mask openings in motors to prevent paint and other materials from entering.
- F. Protect surfaces adjacent to or downwind of Work area from overspray.
- G. Immediately remove coatings that fall on surrounding areas and surfaces not scheduled to be coated.

3.3 SURFACE PREPARATION OF STEEL

- A. Prepare steel surfaces in accordance with Manufacturer's instructions.
- B. Fabrication Defects
 - 1. Correct steel and fabrication defects revealed by surface preparation.
 - 2. Remove weld spatter and slag.
 - 3. Round sharp edges and corners of welds to a smooth contour.
 - 4. Smooth weld undercuts and recesses.
 - 5. Grind down porous welds to pinhole-free metal.
 - 6. Remove weld flux from surface.
- C. Ensure surfaces are dry.
- D. Immersed or Below Grade Surfaces
 - 1. Remove visible oil, grease, dirt, dust, mill scale, rust, paint, oxides, corrosion products, and other foreign matter in accordance with SSPC-SP 10/NACE 2.
- E. Exterior Exposed or Interior Exposed Surfaces
 - 1. Remove visible oil, grease, dirt, dust, mill scale, rust, paint, oxides, corrosion products, and other foreign matter in accordance with SSPC-SP 6/NACE 3.
- F. Interior or Immersed Surfaces, Severe Atmospheres

1. Remove visible oil, grease, dirt, dust, mill scale, rust, paint, oxides, corrosion products, and other foreign matter in accordance with SSPC-SP 5/NACE 1.
 - G. Abrasive Blast-Cleaned Surfaces
 1. Coat abrasive blast-cleaned surfaces with primer before visible rust forms on surface. Do not leave blast-cleaned surfaces uncoated for more than 8 hours.
 - H. Shop Primer
 1. Prepare shop primer to receive field coat in accordance with manufacturer's instructions.
- 3.4 SURFACE PREPARATION OF DUCTILE OR CAST IRON
- A. Prepare ductile or cast iron surfaces in accordance with Manufacturer's instructions.
 - B. Ensure surfaces are clean, dry, and free of oil, grease, dirt, dust, and other contaminants.
- 3.5 APPLICATION
- A. Apply coatings in accordance with Manufacturer's instructions.
 - B. Mix and thin coatings, including multi-component materials, in accordance with manufacturer's instructions.
 - C. Keep containers closed when not in use to avoid contamination.
 - D. Do not use mixed coatings beyond pot life limits.
 - E. Use application equipment, tools, pressure settings, and techniques in accordance with Manufacturer's instructions.
 - F. Uniformly apply coatings at spreading rate required to achieve specified DFT.
 - G. Apply coatings to be free of film characteristics or defects that would adversely affect performance or appearance of coating systems.
 - H. Stripe paint with brush at critical locations on steel such as welds, corners, and edges using specified primer.
- 3.6 REPAIR
- A. Materials and Surfaces Not Scheduled To Be Coated
 1. Repair or replace damaged materials and surfaces not scheduled to be coated.
 - B. Damaged Coatings
 1. Touch-up or repair damaged coatings. Touch-up of minor damage shall be acceptable where result is not visibly different from adjacent surfaces. Recoat entire surface where touch-up result is visibly different, either in sheen, texture, or color.
 - C. Coating Defects
 1. Repair in accordance with manufacturer's instructions coatings that exhibit film characteristics or defects that would adversely affect performance or appearance of coating systems.
- 3.7 FIELD QUALITY CONTROL
- A. Applicator's Services
 1. Verify coatings and other materials are as specified.
 2. Verify surface preparation and application are as specified.

3. Verify DFT of each coat and total DFT of each coating system are as specified using wet film and dry film gauges.
 4. Coating Defects
 - a. Check coatings for film characteristics or defects that would adversely affect performance or appearance of coating systems.
 - b. Check for holidays on interior steel immersion surfaces using holiday detector.
 5. Report
 - a. Submit daily written reports describing work performed, inspections made, and actions taken to correct nonconforming work. Daily reports shall contain, but not be limited to, the following information:
 - 1) Start date and time of work in each area.
 - 2) Weather conditions.
 - 3) Date and time of application for each following coat.
 - 4) Moisture content of substrate prior to each coat.
 - 5) Provisions utilized to maintain temperature and humidity of work area within Manufacturer's recommended ranges.
 - b. Report nonconforming work addressed and any areas not corrected.
 - c. Submit copies of report to Engineer and Contractor.
- B. Manufacturer's Field Services
1. Manufacturer's representative shall provide technical assistance and guidance for surface preparation and application of coating systems and shall be available per paragraph 1.5.C.
- C. Testing:
1. Thickness and Continuity Testing:
 - a. Measure coating thickness specified in mils with magnetic type, dry film thickness gauge, in accordance with SSPC PA 2. Check each coat for correct millage. Do not make measurement before a minimum of 8 hours after application of coating.
 - b. Holiday detect coatings 20 mils thick or less, except zinc primer and galvanizing, with low voltage wet sponge electrical holiday detector in accordance with NACE RP0188.
 - c. Holiday detect coatings in excess of 20 mils dry with high voltage spark tester as recommended by coating manufacturer and in accordance with NACE RP0188.
 - d. After repair and recoated areas have dried sufficiently, retest each repaired area. Final tests may also be conducted by Engineer.
- D. Inspection: Leave staging and lighting in place until Engineer has inspected surface or coating. Replace staging removed prior to approval by Engineer. Provide additional staging and lighting as requested by Engineer.
- E. Unsatisfactory Application:
1. If item has an improper finish color or insufficient film thickness, clean surface and topcoat with specified paint material to obtain specified color and coverage. Obtain specific surface preparation information from coating manufacturer.
 2. Evidence of runs, bridges, shiners, laps, or other imperfections is cause for rejection.
 3. Repair defects in accordance with written recommendations of coating manufacturer.

F. Damaged Coatings, Pinholes, and Holidays:

1. Feather edges and repair in accordance with recommendations of paint manufacturer.
2. Hand or power sand visible areas of chipped, peeled, or abraded paint, and feather the edges. Follow with primer and finish coat. Depending on extent of repair and appearance, a finish sanding and topcoat may be required.
3. Apply finish coats, including touchup and damage-repair coats in a manner that will present a uniform texture and color-matched appearance.

3.8 CLEANING

- A. Remove temporary coverings and protection of surrounding areas and surfaces.
- B. Place cloths and waste that might constitute a fire hazard in closed metal containers or destroy at end of each day.
- C. Upon completion of the Work, remove staging, scaffolding, and containers from Site or destroy in a legal manner.
- D. Remove paint spots, oils, or stains upon adjacent surfaces and floors and leave entire job clean.

3.9 PROTECTION OF COATING SYSTEMS

- A. Protect surfaces of coating systems from damage during construction.

3.10 ATTACHMENTS

- A. The attachments listed below, following “End of Section” are a part of this Specification.
 1. Paint System Data Sheet (PSDS)
 2. Product Data Sheet (PDS)

END OF SECTION

PAINT SYSTEM DATA SHEET

Complete this PSDS for each coating system, include all components of the system (surface preparation, primer, intermediate coats, and finish coats). Include all components of a given coating system on a single PSDS.

Paint System Title (from Spec):		
Coating Supplier:		
Representative:		
Surface Preparation:		
Paint Material (Generic)	Product Name/Number (Proprietary)	Min. Coats, Coverage

PAINT PRODUCT DATA SHEET

Complete and attach manufacturer's Technical Data Sheet to this PDS for each product submitted. Provide Manufacturer's recommendations for the following parameters at temperature (F)/relative humidity:

Temperature/RH	50/50	70/30	90/25
Induction Time			
Pot Life			
Shelf Life			
Drying Time			
Curing Time			
Min. Recoat Time			
Max Recoat Time			

Provide Manufacturer's Recommendation for the following:

Mixing Ratio: _____

Maximum Permissible Thinning: _____

Ambient Temperature Limitations: Min.: _____ Max.: _____

Surface Temperature Limitations: Min.: _____ Max.: _____

Surface Profile Requirements: Min.: _____ Max.: _____

Attach additional sheets detailing manufacturer's recommended storage requirements and holiday testing procedures.

SECTION 26 00 01

GENERAL ELECTRICAL PROVISIONS

PART 1 GENERAL

1.1 SUMMARY

A. Section Includes

<u>Paragraph</u>	<u>Title</u>
1.2	References
1.3	Submittals
1.4	Quality Assurance
2.1	Choice of Materials and Equipment
2.2	Equipment and Materials
2.3	Wire Markers
2.4	Raceway Markers
2.5	Nameplates
2.6	Terminal Blocks
2.7	Electrical Numbering System
2.8	Arc Flash Mitigation Methods
3.1	General
3.2	Wiring Electrically Operated Equipment
3.3	Equipment Operation
3.4	Circuit Continuity
3.5	Cleaning and Painting
3.6	Identification
3.7	Testing and Start-up
3.8	Test Period
3.9	Grounding
3.10	Installation of Equipment
3.11	Temporary Electric Power
3.12	Attachments

B. Scope

1. This section specifies general requirements for electrical work. Detailed requirements for specific electrical items are specified in other sections but are subject to the general requirements of this section. The electrical drawings and schedules included in this project manual are functional in nature and do not specify exact locations of equipment or equipment terminations.
2. Furnish and install all materials, equipment, labor, supervision and services necessary to complete all electrical work specified herein, and shown on the Drawings.

3. Principal Features
 - a. Pump control panel.
- C. Coordination with Other Trades
 1. Furnish and locate all anchor bolts, inserts and supports for installation by the other trades as required. Coordinate the location of all fixtures, outlets, equipment, and devices with other trades to avoid conflicts.
- D. Fees and Tests
 1. Supplier shall be responsible for all fees for permits, inspections, and tests necessary to complete this work. Demonstrate to the Owner and the Engineer that all items of equipment installed are completely operational and free of defects in all modes.

1.2 REFERENCES

A. Definitions

1. Elementary or Schematic Diagram: A schematic (elementary) diagram shows, by means of graphic symbols, the electrical connections and functions of a specific circuit arrangement. The schematic diagram facilitates tracing the circuit and its functions without regard to the actual physical size, shape, or location of the component devices or parts.
2. One-Line Diagram: A one-line diagram shows by means of single lines and graphical symbols the course of an electrical circuit or system of circuits and the components, devices or parts used therein. Physical relationships are usually disregarded.
3. Block Diagram: A block diagram is a diagram of a system, instrument, computer, or program in which selected portions are represented by annotated boxes and interconnecting lines.
4. Wiring Diagram or Connection System: A wiring or connection diagram includes all of the devices in a system and shows their physical relationship to each other including terminals and interconnecting wiring in an assembly. This diagram shall be (a) in a form showing interconnecting wiring only by terminal designation (wireless diagram), or (b) a panel layout diagram showing the physical location of devices plus the elementary diagram.
5. Interconnection Diagram:
 - a. Show all external connections between terminals of equipment and outside points, such as motors and auxiliary devices on interconnection diagrams. Show references to all connection diagrams which interface to the interconnection diagrams. Interconnection diagrams shall be of the continuous line type. Show bundled wires as a single line with the direction of entry/exit of the individual wires clearly shown. Wireless diagrams and wire lists are not acceptable.
 - b. Show each wire identification as actually installed. Use identical wire identification for each end of the same wire. Identify all devices and equipment shall be identified. Show terminal blocks as actually installed and identified in the equipment complete with individual terminal identification.
 - c. Show all jumpers, shielding and grounding termination details not shown on the equipment connection diagrams on the interconnection diagrams. Do not show wires or jumpers shown on the equipment connection diagrams on the interconnection diagram. Show signal and DC circuit polarities and wire pairs. Show spare wires and cables.

6. Arrangement, Layout, or Outline Drawings: An arrangement, layout, or outline drawing is one which shows the physical space and mounting requirements of a piece of equipment. It may also indicate ventilation requirements and space provided for connections or the location to which connections are to be made.
7. Hazardous Area: Any area that is classified based on the properties of the flammable vapors, liquids, or gases, or combustible dusts or fibers that might be present and the likelihood that a flammable or combustible concentration or quantity is present. See NFPA 70 and NFPA 820.
8. Corrosive Area: Any area where gases or chemicals may be present which are corrosive to standard metal or iron products such as carbon steel or ductile iron.

B. Reference Standards

1. This section contains references to the following documents. They are a part of this section as specified and modified. Where a referenced document contains references to other standards, those documents are included as references under this section as if referenced directly. In the event of conflict between the requirements of this section and those of the listed documents, the requirements of this section shall prevail.
2. Unless otherwise specified, references to documents shall mean the documents in effect at the time of Advertisement for Bids or Invitation to Bid (or on the effective date of the Agreement if there were no Bids).
3. If referenced documents have been discontinued by the issuing organization, references to those documents shall mean the replacement documents issued or otherwise identified by that organization or, if there are no replacement documents, the last version of the document before it was discontinued.
4. Where document dates are given in the following listing, references to those documents shall mean the specific document version associated with that date, regardless of whether the document has been superseded by a version with a later date, discontinued or replaced.

Reference	Title
NECA-1	National Electrical Contractors Association – Standard Practices for Good Workmanship in Electrical Contracting
NFPA	National Fire Protection Association
NFPA-70	National Electrical Code (NEC)
NFPA-70E	Standard For Electrical Safety in the Workplace
NFPA 820	Standard for Fire Protection in Wastewater Treatment and Collection Facilities
ACI 318	Building Code Requirements for Structural Concrete

5. Other Reference Documents
 - a. Local, State, and National Electrical Codes.
 - b. National Electrical Code, latest edition.
 - c. Rules of the Electrical Utility and the National Electrical Safety Code.
 - d. Life Safety Code 101.

1.3 SUBMITTALS

A. Action Submittals/Informational Submittals

1. Provide complete manufacturers' descriptive information and shop drawings for all equipment, material and devices furnished under Division 26, Electrical, including certified outline drawings, arrangement drawings, elementary (schematic) diagrams, interconnection and connection diagrams, in accordance with provisions elsewhere in these Contract Documents. Provide the number of copies specified herein for the Engineer, Supplier and Operation and Maintenance Manuals.
2. Provide certified shop drawings, literature and requested samples showing items proposed for use, size, dimensions, capacity, special features required, schematic (elementary) control diagrams, equipment schedules, rough-in, etc., as required by the Engineer for complete review and for use during installation. Use NEMA device designations and symbols for all electric circuit diagrams submitted.
3. Product Data
 - a. Catalog cuts of equipment, devices, and materials requested by the individual specification sections. Include technical specifications and application information, including ratings, range, weight, accuracy, etc. Edit to show only the items, model numbers, and information which apply. Assemble in a folder containing a cover sheet, indexed by item, and cross-referenced to the appropriate specification paragraph.
 - b. In addition to submittals for specific items mentioned above, furnish shop drawing information on the following items:
 - 1) Conduit and fittings.
 - 2) Conductors.
 - 3) Control cable.
 - c. Safety disconnect switch list including legend with equipment tag, equipment description, and power feeder circuit source and location information.
4. Shop Drawings
 - a. Interconnection diagram: Prepare interconnection diagrams depicting all cable requirements together with their actual terminations as specified in paragraph 1.2.A above.
 - b. Conduit layout drawings indicating size, location, and support, for all conduits other than single runs of 1-inch diameter or less cast in concrete construction.
 - 1) Conduit layout drawings shall illustrate a system which conforms to the requirements of paragraph 3.1.B.
 - 2) For layouts that do not conform to 3.1.B, provide engineering design and calculations signed and sealed by a Professional Engineer registered in the state of the project. Engineering design and calculations shall demonstrate that the proposed layout does not impair or significantly reduce the design structural strength.
 - c. Certified arrangement drawings, outline dimensions, and weights for all major (engineered) equipment including, but not limited to:
 - 1) Pump control panel
 - d. Drawings
 - 1) Where the Supplier is required to provide information on drawings as part of the specified work, prepare such drawings on 11-inch by 17-inch bond drafting media complete with borders and title blocks clearly identifying project name, equipment and the scope of the drawing.

2) Drawing quality and size of presentation shall be such as to permit.

5. Special Procedure Submittals

- a. A copy of this specification section, with addendum updates included, and all referenced and applicable sections, with addendum updates included, with each paragraph check-marked to indicate specification compliance or marked to indicate requested deviations from specification requirements. A check mark shall denote full compliance with a paragraph as a whole. If deviations from the specifications are indicated, and therefore requested by the Supplier, each requested deviation shall be underlined and denoted by a number in the margin to the right of the identified paragraph, referenced to a detailed written explanation of the reasons for requesting the deviation. The Engineer shall be the final authority for determining acceptability of requested deviations. The remaining portions of the paragraph not underlined will signify compliance on the part of the Supplier with the specifications.
- b. Failure to include a copy of the marked-up specification sections, along with justification for requested deviations from the specification requirements, with the submittal shall be sufficient cause for rejection of the entire submittal with no further consideration.

B. Closeout Submittals

1. Record Documentation

- a. Maintain at the job site a set of Contract Documents kept current by indicating thereon all changes, revisions and substitutions, between work as specified and as installed.
- b. Furnish Owner with 1 complete set of reproducible drawings and 2 complete, clean sets of Specifications showing installed locations, size, catalog numbers, etc., of all work and material as taken from record documents.
- c. For each piece of equipment, provide 4 sets of manufacturer's printed catalog pages, operating and maintenance instructions, and wiring and connections diagrams. Bind this information into 8½-inch by 11-inch booklets.

1.4 QUALITY ASSURANCE

A. Qualifications

1. Manufacturers

- a. List of Proposed Materials: Submit a complete list of the proposed manufacturers for each of the items listed in the following electrical specifications. Additional submittal data, sufficient to determine equality, shall be required if the Supplier proposes to substitute another manufacturer's equipment.

B. Intent of Drawings

1. Electrical plan drawings show only general locations of equipment, devices and raceways, unless specifically dimensioned. The Supplier shall be responsible for the proper routing of raceway, subject to the review of the Engineer.

C. Departure from Contract Documents

1. Submit to the Engineer, in writing, details of any necessary, proposed departures from these Contract Documents, and the reasons therefor. Submit such requests as soon as practicable and within 30 days after award of the Contract. Make no such departures without written approval of the Engineer.

D. Identification of Listed Products:

1. Electrical equipment and materials shall be listed for the purpose for which they are to be used, by an independent testing laboratory. Three such organizations are Underwriters Laboratories (UL), Canadian Standards Association (CSA), and Electrical Testing Laboratories (ETL). Independent testing laboratory shall be acceptable to the inspection authority having jurisdiction.
 2. When a product is not available with a testing laboratory listing for the purpose for which it is to serve, the product may be required by the inspection authority, to undergo inspection at the manufacturer's place of assembly. All costs and expenses incurred for such inspections shall be included in the original contract price.
- E. Factory Tests:
1. Where specified in the individual product specification section, factory tests shall be performed at the place of fabrication and performed on completion of manufacture or assembly. The costs of factory tests shall be included in the contract price.

PART 2 PRODUCTS

2.1 CHOICE OF MATERIALS AND EQUIPMENT

- A. In submitting substitutions, bidders should note the following minimum considerations:
1. Capacities shown are absolute minimum and must be equaled
 2. Physical size limitations for space allotted
 3. Structural properties
 4. Noise level
 5. Interchangeability
 6. Compatibility with other materials and assemblies
 7. Similar items shall be same manufacture and style wherever possible
- B. All material and equipment, for which a UL, ANSI, or a NEMA Standard is established, shall be so approved and labeled or stamped.
- C. Adhesives are not acceptable as a mounting, supporting, or assembling technique, unless noted otherwise.

2.2 EQUIPMENT AND MATERIALS

- A. General
1. Provide equipment and materials that are new and free from defects.
 2. Provide all material and equipment of the same or a similar type from the same manufacturer throughout the work.
 3. Use standard production materials wherever possible.
 4. NEMA Standards shall be taken as minimum requirements for electrical equipment.
 5. Equipment shall operate properly under a plus or minus 10 percent voltage variation.
 6. 3 Phase power, if necessary, must be obtained from the power company and may not be created using a phase inverter or similar device.
- B. Equipment Finish
1. Unless otherwise specified, electrical equipment shall be painted by the manufacturer as specified in Section 09 91 00 - Painting.

2.3 WIRE MARKERS

- A. Identify each power and control conductor at each terminal to which it is connected. Use identification sleeves on conductors size No. 10 AWG or smaller. Use cable markers of the locking tab type on conductors No. 8 AWG and larger. Use white plastic tabs with conductor identification number permanently embossed.
- B. Identify conductors in accordance with paragraph 2.8.B. Adhesive strips are not acceptable.
- C. Machine print the letters and numbers that identify each wire on sleeves with permanent black ink with figures 1/8-inch high. Use yellow or white tubing for sleeves and size to fit the conductor insulation. Shrink the sleeves with hot air after installation to fit the conductor.
- D. Conductor and Wire Marker Manufacture:
 - 1. TMS Thermofit Marker System by Raychem Co
 - 2. Sleeve style wire marking system by W. H. Brady Co.
 - 3. or engineer approved equal.

2.4 RACEWAY MARKERS

- A. Raceway markers tags:
 - 1. Solid brass with 0.036-inch minimum thickness.
 - 2. Raceway number stamped in 3/16-inch minimum height characters
 - 3. Attached to the raceway with 316 stainless steel wire.

2.5 NAMEPLATES

- A. Provide nameplates made from laminated phenolic plastic.
 - 1. Nominal size: 3/4-inch high by 2 inches long.
 - 2. Black backgrounds with 3/16-inch white letters.
 - 3. Fastened using self-tapping stainless steel screws.
- B. Submit abbreviations to the Engineer prior to manufacture because of space limitations. Nameplate adhesives will not be permitted on the outside of enclosures.

2.6 TERMINAL BLOCKS

- A. Unless otherwise specified, provide panhead strap screw type terminal blocks. Provide terminals with integral marking strips that permanently identify with the connecting wire numbers as shown on the drawings:
 - 1. Terminal blocks for P-circuits (power 208-600 volts)
 - a. Rated not less than the conductor current rating
 - b. Rated not less than 600 volts AC.
 - 2. Terminal blocks for C-circuits and S-circuits:
 - a. Rated not less than 20 amperes
 - b. Rated not less than 600 volts AC.
 - 3. Terminals shall be tin-plated.
 - 4. Insulating material shall be nylon.

2.7 ELECTRICAL NUMBERING SYSTEM

A. Raceway Numbering System

1. Tag raceways at all terminations. Assign raceway numbers in accordance with the following system where raceway numbers have not been assigned:

Raceway Prefix	Type of Function
C	Control or power - 120V or less
H	Power above 600V
N	Pneumatic tubing
P	Power 208V to 600V
S	Signal - data communication or instrumentation
X	Spare

2. Prefixes shall be followed by a 4-digit number. Add a letter suffix to distinguish the raceways where more than one raceway is routed to a particular piece of equipment.
 - a. Example: Raceway number = P3109A where:
 - 1) P = conduit contains power
 - 2) 3109 = unique 4-digit number
 - 3) A = letter to distinguish raceways to same equipment

B. Conductor Numbers

1. Identify conductors with numbers at both ends. Conductor tag numbers shall consist of the equipment number followed by a dash followed by the conductor number specified on the control diagram.
2. Example: Equipment Tag number = 1900 - L1 where:
 - a. 1900 = cable number
 - b. L1 = conductor number
3. Provide the same conductor number for conductors in parallel or in series between equipment. Provide the same conductor number for neutral conductors. Wherever possible, use the same conductor number as the equipment terminal to which it connects.
4. Where factory-wired equipment has terminal numbers different than the conductor numbers shown on the control diagrams:
 - a. Both shall be shown on the interconnection diagram
 - b. Include a copy of the interconnection diagram inside of the equipment cabinet.

2.8 ARC FLASH MITIGATION METHODS

- A. The following mitigation method requirements apply to all power distribution and utilization equipment supplied, for any products supplied on the project and applies to all equipment divisions in the Contract Documents. Refer to the NFPA-70 (NEC), and NFPA-70E (Standard for Electrical Safety in the Workplace) for equipment labeling requirements.

B. Equipment Labels:

1. Install County standard equipment labels on the outside of the electrical equipment enclosure, cabinet, or panels to avoid opening the equipment to access the arc flash data or the PPE requirements.

- C. Hinged Doors:
 1. Provide hinged rear doors on power distribution equipment where back access is shown.
- D. Remote Racking Devices:
 1. Provide remote racking devices on power distribution equipment for Operators to insert or remove rack-mounted breakers, rack-mounted devices, or auxiliary equipment drawers into the associated equipment location.
- E. Insulated Power Bus and Insulated Cable Boots:
 1. Provide insulated power bus in power distribution equipment where accessible to installers or maintenance workers.
 2. Provide cable boots for power conductor connections to insulate the exposed power conductor connections.
- F. View Windows for Monitoring:
 1. Provide protected view windows into cabinets that allow infra-red analyzers, monitors, or cameras to monitor hot temperature for unusual heat generated by deteriorating connections. The view windows shall have a method to move the window protector and hold-in-place during the monitoring operation.
- G. Power and Control Equipment Separation:
 1. Provide separation between power equipment within an enclosure, cabinet, or panel by the uses of barriers, separate access doors, or by other means.
 2. Provide separation barriers between main breaker feeders coming into equipment and other termination points or bussing on the load side of the main breaker.
- H. Automatic Shutters:
 1. Provide automatic shutters, where possible, to close the access to the power bus when a power device is not engaged.
- I. Maintenance Switches
 1. Install circuit breaker maintenance switches as specified and where shown to make circuit breakers operate in the instantaneous region of the trip curve in all modes (LSIG).

PART 3 EXECUTION

3.1 GENERAL

- A. Construction:
 1. Perform the work under Division 26 in accordance with these specifications.
 2. Refer to the National Electrical Contractors Association's (NECA) National Electrical Installation Standards (NEIS) for Standard Practices for Good Workmanship in Electrical Contracting (NECA-1) as a minimum baseline of quality and workmanship for installing electrical products and systems that defines what is meant by "neat and workmanlike" as required by the National Electrical Code Section 110-12. Specified requirements supersede NECA practices.
 3. Electrical layout drawings are diagrammatic, unless otherwise detailed or dimensioned. Coordinate the location of electrical material or equipment with the work.
 4. Major electrical openings may compromise the structural integrity of the slab and wall elements. Major electrical openings are defined as openings or penetrations greater

than two times the wall thickness in any dimension, and include duct bank transitions into a building through structural elements. Construct major electrical openings according to standard details on the drawings, up to an opening dimension of three feet. For opening dimensions greater than three feet, construct walls and slabs as specifically detailed on the drawings for that case. Submit major electrical openings proposed by the Supplier to the Structural Engineer of Record for the project for review.

5. Minor changes in location of electrical material or equipment made prior to installation shall be made at no cost to the Owner.

B. Conduits in Concrete Construction:

1. Conduits for power, control and instrumentation may be embedded in and pass through concrete construction subject to the limitations in this paragraph. Where concrete strength or serviceability requirements prevent the direct embedment of conduit, provide adequate support, bracing, and serviceability details:
 - a. Do not significantly impair concrete strength by the embedment of conduits in or through structural sections.
 - b. Conform conduit layout shall to the requirements of ACI 318, Sections 3.3 – Aggregates and 6.3 – Conduits and Pipes Embedded in Concrete.
 - c. Treat conduits similarly to reinforcing steel for purposes of clearance. In general, code sections require conduit spacing the greater of:
 - 1) 1.33 times the maximum concrete aggregate size, clear
 - 2) Three diameters center to center
 - d. Alternate spacing and layout shall be as reviewed and accepted by the Engineer.
 - e. Detail and construct to prevent liquid and moisture penetration through the wall or slab section for conduit and raceway penetrations through walls and slabs where:
 - 1) one side is a conditioned or an occupied space and the other side not, or
 - 2) one side has liquid or groundwater contact and the other not.

C. Housekeeping:

1. Protect electrical equipment from dust, water and damage. Wipe motor control centers, switchgear, and buses free of dust and dirt, keep dry, and vacuum on the inside within 30 days of acceptance of the work.
2. Before final acceptance, touch up any scratches on equipment as specified in Section 09 91 00.
3. Protect electrical equipment temporarily exposed to weather, debris, liquids, or damage during construction as specified in Section 01 66 00.

D. Electrical Equipment Labeling

1. Provide electrical equipment with field marked signs and labeling to warn qualified persons of the potential electric arc flash hazards per NEC Article 110.16 Flash Protection.
2. Install NFPA 70E labels on electrical equipment stating the results of the Arc Flash analysis.
3. Field label electrical distribution equipment and utilization equipment to identify the power source and the load as specified. Refer to NEC Article 110.22 for Identification of Disconnecting Means installation criteria. Specific information is required such as the equipment tag number and equipment description of both the power source and the load equipment.

E. Safety Disconnect Switches:

1. Provide heavy duty fused and non-fused disconnect switches with current range of 30 to 600 amperes as shown on the drawings with the enclosure type matching the area rating. Provide lock-off provision for a hasp padlock. Provide visible knife blades through a cover viewing window. Provide shielded or insulated line terminals with quick-make / quick-break switch operator. Provide internal barrier kit for additional personnel barrier from accidental contacts with live parts. Provide a legend plate with equipment tag, equipment description, and power feeder circuit source and location identification.
2. Disconnects shall include one auxiliary contact that operates with the power switch blades. Wire the auxiliary contact as shown on the drawings for remote status monitoring of the disconnect position where shown or for disconnecting motor space heater where shown.
3. Provide Class R rejection type fuse clips sized for UL Class R, one-time, time-delay fuses. Fuse assembly shall have a minimum short circuit capacity of 100,000 amps symmetrical. Provide fuses as shown and one set of spare fuses with each switch.

F. Motor Connections

1. Verify that the motors are purchased with the correct size motor termination boxes for the circuit content specified as shown on the power single line diagrams or submit custom fabrication drawing indicating proposed motor termination box material, size, gasket, termination kit, grounding terminal, motor lead connection method, and motor terminal box connection/support system. Verify the motor termination box location prior to raceway rough-in.

G. Conductor Installation

1. Do not use an enclosure containing disconnecting means, overcurrent devices, or electrical equipment as a wireway or raceway for conductors not terminating within the enclosure. Provide wireways, raceways, termination boxes, or junction boxes external to the enclosure for the other conductors.

3.2 WIRING ELECTRICALLY OPERATED EQUIPMENT

- A. Make all electrical connections to all equipment requiring electrical power. This responsibility applies to equipment furnished under this and other Divisions and by the Owner.

3.3 EQUIPMENT OPERATION

- A. This Division is responsible for:
1. Proper phase rotation
 2. Observing that lubrication has been properly performed
 3. That motors operate within nameplate limits
 4. Adjustment of circuit breaker and MCP trip settings.
 5. Adjustment of VFD or soft starter operational parameters and protection settings.

3.4 CIRCUIT CONTINUITY

- A. Provide a complete installation free of short circuits, grounds, open circuits, and other defects. Make tests as required to prove that all parts of installation meet specified performances.

3.5 CLEANING AND PAINTING

- A. Thoroughly clean fixtures, panels and equipment. Touch-up or repaint all equipment as required to present a clean professional appearance. Prime and paint all ferrous metal which is not otherwise protected against corrosion. Paint exposed pipe threads with Bitumastic No. 50.

3.6 IDENTIFICATION

- A. Identify all major items of equipment including controls, panels, switches, contactors, motor starters, junction boxes and metering by permanent nameplates, with wording approved by Engineer. Secure metal nameplate frame with screws or brads. Adhesives are acceptable on components within NEMA 1 enclosures.
- B. Install nameplates to be easily visible. Coordinate notations on nameplates to correspond to those shown on record drawings.
- C. Identify all conduits with a stamped stainless steel tag system (Brady or approved equal). Permanently attach conduit tags to each exposed end of conduit runs such as in manholes, pull boxes, panels, junction boxes, etc. and at each point of entry into a structure or building. Stamp each tag with the appropriate conduit number per the conduit and cable schedules.
- D. Identify each instrument with a stamped stainless steel tag system (Brady or approved equal). Permanently attach instrument tags to each individual instrument and stamp with the appropriate number per instrument specification section.
- E. Identify each cable with a permanent labeling system (Brady Catalog Number B-292 with printed legends or approved equal). Label instrumentation cables with the appropriate instrument number of the originating signal (Ex. FT-2020-1). Label multiplex cables, power and control cables with the appropriate cable number per the conduit and cable schedules.
- F. Identify all circuit breakers, control panels, control cabinets, etc. with permanently mounted phenolic labels.

3.7 TESTING AND START-UP

- A. General:
 - 1. Prior to energizing the electrical circuits, perform insulation resistance measurements tests using a 1000-volt megohmmeter to verify the conductor is acceptable for use on the project. Record the test measurements on the specified forms and provided in accordance with paragraph 1.3 above.
 - 2. Prior to energizing any equipment, thoroughly vacuum clean the equipment with an industrial type vacuum cleaner. Clean the outside of all electrical equipment and touch-up paint as required to leave equipment in an "as purchased" condition.
 - 3. During start-up of new equipment, provide sufficient personnel to aid with start-up of the electrical equipment to remove any faults, and to make the necessary adjustment for proper operation of electrical equipment and installation. This includes sufficient personnel to aid equipment service personnel in their check-out of the electrical equipment and service.
 - 4. Furnish all testing equipment.
 - 5. Correct all failures under tests due to defective material or poor workmanship at no expense to the Owner.
 - 6. Do not, under any circumstances, energize any electrical equipment covered by these Specifications without first obtaining permission from the Engineer.

- B. Grounding
 - 1. After all connections have been made to the ground, make ground tests to verify its adequacy.
- C. Insulation Resistance Measurements:
 - 1. General:
 - a. Make insulation resistance measurements on conductors and energized parts of electrical equipment. Minimum acceptable values of insulation resistance shall be in accordance with the applicable ICEA, NEMA or ANSI standards for the equipment or material being tested, unless otherwise specified. Record the ambient temperature at which insulation resistance is measured on the test form.
 - b. Record insulation resistance measurements in a format similar to Form 26 00 01-A, provided at the end of this Section. Insulation with resistance of less than 10 megohms is not acceptable.
 - 2. Conductor and Cable Tests: Measure the phase-to-ground insulation resistance for all circuits rated 120 volts and above except lighting circuits. Measurements may be made with motors and other equipment connected. Disconnect solid state equipment unless the equipment is normally tested by the manufacturer at voltages in excess of 1000 volts DC.
 - 3. Motor Tests:
 - a. Complete the Installed Motor Test Form, 26 00 01-B, provided at the end of this Section, for each motor after installation.
 - b. Measure the insulation resistance of motors before they are connected. For motors 50 HP and larger measure the insulation resistance at the time of delivery, as well as, when they are connected. Insulation resistance values less than 10 megohms are not acceptable.
- D. Pre-Functional Test Checkout:
 - 1. Perform functional testing in accordance with the requirements of Section 01 91 13. Prior to functional testing, adjust and make operative all protective devices.
 - a. Submit a description of the proposed functional test procedures prior to the performance of functional checkout.
 - b. Prior to energization of equipment, perform a functional checkout of the control circuit. Checkout:
 - 1) Energizing each control circuit.
 - 2) Operating each control device, alarm device, or monitoring device.
 - 3) Operate each interlock to verify that the specified action occurs.
 - 2. Verify motors are connected to rotate in the correct direction. Verification may be accomplished by momentarily energizing the motor, provided the Supplier confirms that neither the motor nor the driven equipment will be damaged by reverse operation or momentary energization.
- E. Insert typewritten directories in all panels showing the designation of each circuit. Furnish all power and replacement fuses necessary for testing.

3.8 TEST PERIOD

- A. Each piece of equipment shall continue to meet performance specifications throughout the first year of actual operation. Replace or repair any defect due to faulty workmanship or

material which develops within 1 year from date of acceptance. This guaranty shall cover both material and labor.

- B. For first year after final acceptance, provide, at no cost to Owner, any required maintenance and service necessary to assure the proper operation of the system. Date of acceptance shall be certified by Engineer as that date on which the contract has been satisfactorily completed in accordance with the Contract Documents.

3.9 GROUNDING

- A. See section 26 05 26 – Grounding of these specifications.

3.10 INSTALLATION OF EQUIPMENT

- A. The electrical contractor shall coordinate with the Supplier and Owner in order to have electric power available when required.

3.11 TEMPORARY ELECTRIC POWER

- A. Refer to General Conditions and/or other drawings in these Contract Documents for necessary provisions for electric power used during construction.

3.12 ATTACHMENTS

- A. Attachments listed below, following “END OF SECTION,” are a part of this Specification:

Form No.	Title
26 00 01-A	Wire and Cable Resistance Test Data Form
26 00 01-B	Installed Motor Test Data Form
26 00 01-C	Dry Transformer Test Data Form
26 00 01-G	Protective Relay Test Form
26 00 01-L	Neutral Ground Resistor Test

END OF SECTION

26 00 01-A. WIRE AND CABLE RESISTANCE TEST DATA FORM

Wire or Cable No.: _____ Temperature, °F: _____

Location of Test	Insulation resistance, megohms
1.	
2.	
3.	
4.	
5.	
6.	
7.	

CERTIFIED _____ Date _____
 Contractor's Representative

WITNESSED _____ Date _____
 Owner's Representative

26 00 01-B. INSTALLED MOTOR TEST FORM

Motor Equipment Number: _____ Date of test: _____

Equipment Driven: _____

MCC Location: _____

		Ambient temp	°F
Resistance:			
Insulation resistance phase-to-ground megohms:			
Phase A		Phase B	Phase C
Current at Full Load:			
Phase		Current, amps	
Phase		Current, amps	
Phase		Current, amps	
Thermal Overload Device:	Manufacturer/catalog #	Amperes	
Circuit breaker (MCP) setting:			

Motor Nameplate Markings:

Mfr		Mfr Model		Frame		HP	
Volts		Phase		RPM		Service factor**	
Amps		Freq		Ambient temp rating			°C
Time rating	(NEMA 1-10.35)			Design letter**	(NEMA MG-1.16)		
Code letter				Insulation class			

**Required for 3-phase squirrel cage induction motors only.

CERTIFIED _____ Date _____
Contractor's Representative

WITNESSED _____ Date _____
Owner's Representative

26 00 01-C. DRY TRANSFORMER TEST DATA FORM

(Note: Use Data Form for dry type transformers with voltage rating of 600 Vac or less and sizes to 167 kVA single phase and 500 kVA three phase. Use NETA Test Forms and Test Procedures for higher voltages and larger transformers.)

Equipment Tag No.: _____ Temperature Rating: _____

Description/Location: _____ Feeder size/Source: _____

Primary Voltage: _____ Secondary Voltage: _____ Winding Connection: _____

A. VISUAL INSPECTION

Transformer Inspection	Pass	Fail	Note
1. Nameplate data as specified			
2. Mechanical condition			
a. Free of dents and scratches			
b. Anchored properly			
c. Shipping brackets removed			
d. Spacing from wall per nameplate			
3. Grounding *			
a. Equipment grounding			
b. System grounding			

B. INSULATION-RESISTANCE TESTS:

Perform tests with calibrated megohmmeter. Apply 1000 Vdc test voltage for 60 seconds and record readings in megohms at 30-seconds and 60-seconds intervals.

Test Group	Resistance between		30-second reading	60-second reading	Absorption Ratio Index 60-sec. / 30-sec.
Primary Winding to ground	A	GRD			
	B	GRD			
	C	GRD			
Secondary Winding to ground with * N-G Bond removed	a	GRD			
	b	GRD			
	c	GRD			
Primary Winding to Secondary Winding	A	a			
	B	b			
	C	c			

Submit resistance readings to the Engineer immediately after the tests that are less than the manufacturer's recommended value or less than 10-megohms. Record the Absorption Ratio Index values for future reference. Ratio must be 1.0 or greater, with infinity (∞) equal to 1.0.

Contractor Representative Certified: _____ Date _____

Owner Representative Witnessed: _____ Date _____

26 00 01-G. PROTECTIVE RELAY TEST FORM

Location: _____

Switchgear Breaker No.: _____

Protective Relay Description: _____

The protective relays shall be tested in the following manner:

1. Each protective relay circuit shall have its insulation resistance tested to ground.
2. Perform the following tests on the specified relay setting:
 - a. Pickup parameters on each operating element.
 - b. Timing test shall be performed at three points on the time dial curve.
 - c. Pickup target and seal-in units.

The results shall be recorded and signed. A copy shall be given to the Engineer.

26 00 01-L. NEUTRAL GROUNDING RESISTOR TEST

Equipment No.: _____

Location: _____

The pickup and time delay setting on the ground fault relay shall be set in accordance with Division 26.

1. The transformer neutral insulation resistance shall be measured with and without the grounding resistor connected to insure no parallel ground paths exist.
2. The protective relay pickup current shall be determined by injecting test current into the current sensor. The pickup current should be within 10 percent of the dial setting. Record the dial setting and actual pickup tie.
3. The relay timing shall be tested by injecting 150 and 300 percent of pickup current into the current sensor. The relay timing shall be in accordance with the manufacturer's published time-current characteristic curves. Record the relay timing at 150 and 300 percent of pickup current.
4. The circuit interrupting device shall be operated by operating the relay.

The results shall be recorded and signed by the Contractor and Engineer. A copy shall be given to the Engineer.

SECTION 26 00 02

BASIC MATERIALS AND METHODS

PART 1 GENERAL

1.1 SUMMARY

A. Section Includes

<u>Paragraph</u>	<u>Title</u>
1.2	References
1.3	Submittals
1.4	Quality Assurance
1.5	Delivery, Storage, and Handling
2.1	Hazardous Areas
2.2	Materials
2.3	Control Devices
2.4	Control Relays
2.5	Magnetic Contactors
2.6	Safety Disconnect Switches
2.7	Overcurrent Protection
2.8	Elapsed Time Indicators
2.9	Current Transformers and Transducers
2.10	Terminal Strips, Blocks, and Devices
2.11	Intrusion Devices
2.12	Thermostats
2.13	Static Ground Indicator
2.14	Nameplates
3.1	General
3.2	Conduit Installation
3.3	Cutting and Patching
3.4	Equipment Mounting

B. Scope

1. Provide all labor, equipment and materials required to complete the installation specified herein, and shown or scheduled on the Drawings. Since the drawings are schematic, all fittings, connectors, etc. are not shown, but shall be furnished as required for a complete and functional installation.

C. Description

1. The vendor, manufacturer, and custom control panels shall provide enclosures, selector switches, pushbuttons, indicators, terminal strips, surge devices, nameplates, testing procedures, wiring method, wiring color coding, wire labeling, separation between

power, controls, and instruments, hardwired logic relays or PLC logic products as specified herein and in Section 40 90 01.

2. This section specifies electrical control and monitoring devices:
 - a. Control Devices:
 - 1) Pushbuttons
 - 2) Selector Switches
 - 3) Indicating Lights
 - 4) Control Station Enclosures
 - b. Control Relays:
 - 1) Load-Switching
 - 2) Logic Level Switching
 - 3) Timers and Time Switch
 - 4) Alternators
3. This section specifies power devices:
 - a. Magnetic Contactors:
 - 1) Lighting Contactors
 - 2) Motor Contactors
 - b. Safety Disconnect Switches
 - c. Manual starters – Individual Motor Starters
 - d. Field Instrument and Field Analyzer: Key-Switch in control station with surge devices
 - e. Overcurrent Protection: Circuit breakers
 - f. Elapsed Time Indicators
 - g. Current transformers and transducers
 - h. Time Switch
 - i. Motor Driven Timers – On Delay and Off Delay
 - j. Intrusion Switches and Override Key Switches
 - k. Thermostats
 - l. Static Ground Indicator and Interlock System
4. Request clarification where conflicts occur with this section and other sections in these Specifications.

1.2 REFERENCES

A. Reference Standards

1. This section contains references to the following documents. They are a part of this section as specified and modified. Where a referenced document contains references to other standards, those documents are included as references under this section as if referenced directly. In the event of conflict between the requirements of this section and those of the listed documents, the requirements of this section shall prevail.

2. Unless otherwise specified, references to documents shall mean the documents in effect at the time of Advertisement for Bids or Invitation to Bid or on the effective date of the Agreement if there were no Bids.
3. If referenced documents have been discontinued by the issuing organization, references to those documents shall mean the replacement documents issued or otherwise identified by that organization or, if there are no replacement documents, the last version of the document before it was discontinued.
4. Where document dates are given in the following listing, references to those documents shall mean the specific document version associated with that date, regardless of whether the document has been superseded by a version with a later date, discontinued or replaced.

Reference	Title
NEMA 250	Enclosures for Electrical Equipment (1000 volts maximum)
NEMA ICS 1	General Standards For Industrial Controls and Systems
NEMA ICS 2	Industrial Control Devices, Controllers, and Assemblies
NEMA KS 1	Enclosed Switches

5. Other Reference Documents
 - a. Local, State, and National Electrical Codes.
 - b. National Electrical Code, latest edition.
 - c. Rules of the Electrical Utility and the National Electrical Safety Code.
 - d. Life Safety Code 101.
 - e. NECA Standard of Installation.
 - f. NFPA (National Fire Protection Association).

1.3 SUBMITTALS

A. Action Submittals/Informational Submittals

1. Provide shop drawings and product data for the following items:
 - a. Pump control panel
2. A list of product manufacturers is required for all other items covered by these Specifications.
3. Shop Drawings
 - a. Arrangement drawings of the panel enclosure indicating the front door and panel equipment arrangement and dimensions, and enclosure type.
 - b. Nameplate legend with engraving and sizes.
 - c. Internal layout drawings showing all components.
 - d. List of materials and components with the layout drawings.
 - e. Elementary / schematic diagrams
 - f. Internal wiring connection diagrams.
 - g. External wiring interconnection diagrams including interlocks.
 - h. Power and control single line diagrams, where motor controllers are included.

4. Manufacturer's catalog data for all material provided under this section shall be assembled in a folder with each page clearly marked with the item model number and reference number to the specification.
5. Special Procedure Submittals
 - a. A copy of this specification section, with addendum updates included, and all referenced and applicable sections, with addendum updates included, with each paragraph check-marked to indicate specification compliance or marked to indicate requested deviations from specification requirements. A check mark shall denote full compliance with a paragraph as a whole. If deviations from the specifications are indicated, and therefore requested by the Contractor, each requested deviation shall be underlined and denoted by a number in the margin to the right of the identified paragraph, referenced to a detailed written explanation of the reasons for requesting the deviation. The Engineer shall be the final authority for determining acceptability of requested deviations. The remaining portions of the paragraph not underlined will signify compliance on the part of the Contractor with the specifications.
 - b. Failure to include a copy of the marked-up specification sections, along with justification for requested deviations from the specification requirements, with the submittal shall be sufficient cause for rejection of the entire submittal with no further consideration.

1.4 QUALITY ASSURANCE

- A. Where not otherwise specified, provide all material and methods of the highest industrial quality suitable for the application.

1.5 DELIVERY, STORAGE, AND HANDLING

- A. Storage and Handling Requirements
 1. Protect all panelboards, motor starters, transformers, and other electrical equipment that is stored prior to installation, or that is installed outdoors, from corrosion and rust with a product equal to Zerust Vapor Capsules or Cutler-Hammer Oxidation Inhibitor Capsules.

PART 2 PRODUCTS

2.1 HAZARDOUS AREAS

- A. Provide devices, materials, and equipment for installation in hazardous areas that are specifically approved for installation in hazardous areas of the Class, Division and Group indicated, and are of construction that will ensure safe performance under conditions of proper use and maintenance. Provide devices, materials, and equipment meeting the requirements of the NEC [NFPA 70 (latest edition)], applicable state and local codes, and the authority enforcing these codes. Acceptable manufacturers: Crouse Hinds, Appleton, or engineer approved equal.

2.2 MATERIALS

- A. Conduits
 1. See Section 26 05 33.13 – Conduit
- B. Wire and Cable
 1. See Section 26 05 19 – Wire and Cable
- C. Supporting Devices

1. Expansion and/or Deflection Fittings
 - a. O.Z. Gedney, Appleton, Spring City or engineer approved equal.
 2. Channel Support
 - a. Unistrut, Kindorf, Super Strut, or equal. Provide supports that are PVC coated galvanized steel or PVC coated aluminum. Do not use uncoated galvanized steel. Recoat cut ends of supports with a PVC like coating.
 - b. Stainless steel, type 316 may be used in lieu of PVC coated supports.
 3. Fastening Devices
 - a. Caddy, Appleton, or engineer approved equal.
 4. Cable Ties
 - a. Panduit, Thomas & Betts, or engineer approved equal.
- D. Wall and Floor Seals
1. Wall seals are required for all wall penetrations below grade. Floor seals are not required for slab on grade penetrations but are required for floors below grade.
 2. Provide seals manufactured by Spring City, O.Z. Gedney, or engineer approved equal.
- E. Electrical Transient Protection
1. General
 - a. Protect all elements of the Pump Station Control Panel (PSCP) against damage due to electrical transients induced in interconnecting lines by lightning and nearby electrical systems. As a minimum, provide surge suppressors at the following:
 - 1) At any connection at AC power to PSCP.
 - 2) At analog or digital monitoring or controls (DI, DO and AI).
 - 3) Output of DC power supply.
 - 4) Ethernet cables.
 - b. Suppressors on 120 V AC Power Supply Connections
 - 1) Construction: First stage high energy metal oxide varistor and second stage bipolar silicon avalanche device separated by series impedance. Grounding wire, stud or terminal provided.
 - 2) Occurrences: Suppressor tested and rated for a minimum of 50 occurrences of IEEE 587 Category B test waveform.
 - 3) Clamping voltages: 350 volts or less for first stage, 210 volts or less for second stage.
 - 4) Response: 5 nanoseconds maximum.
 - 5) Recovery: Automatic
 - 6) Continuous operation: 5 amps minimum at 130 volts AC for suppressor on power supply for one (1) 4-wire transmitter or receiver, 20 amps minimum otherwise.
 - 7) Temperature range: -20 degrees C to + 85 degrees C.
 - 8) Manufacturers: EDCO HSP-121, Phoenix Contact FSP-1, Schneider Electric TVS120LC, or engineer approved equal.
 - c. Suppressor on Analog Signal Lines

- 1) Construction: First stage high energy metal oxide varistor and second stage bipolar silicon avalanche device separated by series impedance. Grounding wire, stud or terminal provided.
- 2) Test waveform: Linear 8 microsecond rise in current from zero amps to a peak current value followed by an exponential decay of current reaching for half the peak value in 20 microseconds.
- 3) Surge rating: Suppressor tested and rated for a minimum of 50 occurrences of 2000 amp peak test waveform.
- 4) DC clamping voltage: Twenty to forty percent above operating voltage for circuit. Clamping voltage tolerance less than plus or minus 10 percent.
- 5) Response: 5 nanoseconds.
- 6) Recovery: Automatic.
- 7) Maximum loop resistance: 18 ohms per conductor.
- 8) Temperature range: -20 degrees C to + 85 degrees C.
- 9) Approved vendor EDCO PC-642 or SRA-64 Series or engineer approved equal.

2.3 CONTROL DEVICES

A. Pushbuttons

1. Provide flush head, heavy-duty pushbuttons, with NEMA rating to match enclosure type. Operator colors as follows:
 - a. Green – start function
 - b. Red – stop functions
 - c. Black – all other functions.
2. The escutcheon legend shall be as specified on the drawings.
3. Other Features
 - a. UL Listed.
 - b. Dielectric Strength: 1300 Volts for one minute for Logic Reed contacts, 2200 Volts for one minute for other contacts.
 - c. 30.5mm mounting hole.
 - d. Temperature operating range –10 degree C. to +55 degree C.
 - e. Momentary contact type
 - f. When switching circuits are monitored by programmable controllers or other solid state circuits, furnish hermetically-sealed, logic-reed type contacts rated not less than 0.15 amperes at 150 Vac and 0.06 amperes at 30 Vdc.
 - g. When switching circuits are not monitored by programmable controllers or other solid state circuits, furnish contacts with NEMA Utilization Category rating A600 rated not less than 10 amperes continuous and 6 amperes break at 120 Vac.
4. Manufacturer: Allen-Bradley 800T/800H series or engineer approved equal.

B. Selector Switches

1. Provide heavy-duty selector switches with NEMA rating to match enclosure type. Selector switches shall have maintained position contacts. Provide switches with

contact blocks and number of positions as required for performing the specified or indicated operations.

2. The escutcheon legend shall be as specified on the drawings.
3. Other Features
 - a. UL Listed.
 - b. Dielectric Strength: 1300 Volts for one minute for Logic Reed contacts, 2200 Volts for one minute for other contacts.
 - c. 30.5mm mounting hole.
 - d. Temperature operating range -10 degree C. to +55 degree C.
 - e. Standard knob operator (not lever type nor wing lever type)
 - f. Number of positions and contact configuration as shown on Drawings.
 - g. When switching circuits are monitored by programmable controllers or other solid state circuits, furnish hermetically-sealed, logic-reed type contacts rated not less than 0.15 amperes at 150 Vac and 0.06 amperes at 30 Vdc.
 - h. When switching circuits are not monitored by programmable controllers or other solid state circuits, furnish contacts with NEMA Utilization Category rating A600 rated not less than 10 amperes continuous and 6 amperes break at 120 Vac.
4. Manufacturer: Allen-Bradley 800T/800H series or equal.
5. Provide a lock-out style selector switch for locking on or locking off the 120Vac power source for field instruments and field analyzers specified in Section 40 96 20 – Instrument Index. The selector switch shall use a control station in NEMA-12, 4, 4X, or 7 as required by the area classification. Provide O-Z/Gedney Class 441 with two position key-operated maintained contact switch. Provide surge protection device that matches the enclosure type of the power disconnect type control station, field instrument, or field analyzer: Telematic TP48 transmitter surge protection device or engineer approved equal.

C. Indicating Lights

1. Red, amber, green, and blue indicating lights shall be heavy-duty full voltage 120Vac or 24Vdc push-to-test LED type with NEMA rating to match enclosure type for installation in a 30.5mm hole. Furnish with 28 chip high visibility LED. The escutcheon and lens color shall be as shown on Drawings or scheduled.
2. White indicating lights shall be as above.
3. Manufacturer:
 - a. Allen-Bradley 800H-QRTH10 series or equal for 120Vac applications with colors other than white.
 - b. Allen-Bradley 800HQRTH24 series or equal for 24Vdc applications with colors other than white.
 - c. Allen-Bradley 800H-QRT10 series or equal for 120Vac applications with white.
 - d. Allen-Bradley 800H-QRT24 series or equal for 24Vdc applications with white.
4. Indicating Light Lens Color:

Lens Color	Typical Function	Example
Red	Danger, running	Equipment operating, motor running, valve open, power voltage applied, cycle in automatic
Amber	Fault condition, attention	Equipment failure, status abnormal

Green	Ready condition	End of cycle; unit or head returned; motors stopped; motion stopped; contactors open, valve closed
White or Clear	Normal Condition	Normal pressure of air, water, lubrication, control power on, status okay
Blue	Advisory+	Control mode not in automatic

D. Control Station Enclosures

1. Enclosures locations and ratings:
 - a. Indoors: NEMA 12
 - b. Outdoors and Corrosive areas: NEMA 4X stainless steel, with white baked enamel coating
 - c. NEC 500 Hazardous Areas: NEMA 7.

E. Control Power Transformers

1. Sized for the panel devices and products.
2. Dual primary and single secondary fusing.

2.4 CONTROL RELAYS

A. Load-Switching Control Relays

1. Provide heavy-duty machine tool type control relays used for switching loads such as solenoids, actuators, contactors, motor starter coils, remote interlocking, etc.
2. Provide 4-pole contacts that are field interchangeable to either normally-open or normally-closed. Relay shall be capable of accepting a 4-pole adder.
3. AC relays shall have NEMA A600 contact ratings and electrical clearances for 600 volts. DC relays shall have NEMA P300 contact ratings and electrical clearances for 250 volts.
4. Manufacturer: Allen Bradley Bulletin-700, Square D Class 8501, or engineer approved equal.

B. Logic Level Switching Control Relays

1. Control relays for signal circuits shall have a minimum of three SPDT, gold-flashed, fine silver contacts rated 3-ampere resistive at 120Vac or 28Vdc.
2. Provide plug-in type control relays with heavy-duty, barrier-protected screw terminal sockets and clear polycarbonate dust cover with clip fastener.
3. AC models shall have neon lamp indicator wired in parallel with coil. DC models shall have LED lamp indicator wired in parallel with coil.
4. Manufacturer: Potter Blumfield series KUP; Schrack Series RA; or engineer approved equal

C. Timers

1. Multi-function, micro-controller based, socket mounted timing relay.
2. Single functions:
 - a. Delay on Make
 - b. Delay on Break

- c. Recycle (on time first, equal recycle delays)
 - d. Single shot
 - e. Interval
 - f. Trailing edge single shot
 - g. Inverted single shot
 - h. Inverted delay on break
 - i. Accumulative delay on make
 - j. Re-triggerable single shot
3. Dual functions:
- a. Delay on make/delay on break
 - b. Delay on make/recycle (on time first, equal recycle delays.)
 - c. Delay on make/interval
 - d. Delay on make/single shot
 - e. Interval/recycle (on time first, equal recycle delays)
 - f. Delay on break/recycle (on time first, equal recycle delays)
 - g. Single shot/recycle (on time first, equal recycle delays)
 - h. Recycle – both times adjustable (on time first)
 - i. Recycle – both times adjustable (off time first)
 - j. Interval/delay on make
 - k. Accumulative delay on make/interval
4. Time delay range, switch selectable:
- a. Single function 0.1 second to 1,705 hours in 8 ranges.
 - b. Dual function 0.1 second to 3,100 minutes in 8 ranges.
 - c. Setting accuracy +/- 1 percent or 50 milliseconds, whichever is greater.
 - d. Repeat accuracy +/- 0.1 percent or 16 milliseconds, whichever is greater.
5. Output:
- a. Two Form-C electromechanical isolated contacts rated 10-amperes resistive at 240Vac
 - b. Rated 1/3-horsepower at 120 or 240Vac
 - c. Double-pole double-throw: DPDT.
 - d. Mechanical life: 10,000,000 operations
6. Electrical life: 1,000,000 operations at full load.
7. Mounting: Magnal Plug 11-pin socket
8. Environment: -20 to +65 degree C.
9. Manufacture:
- a. ABB / SSAC's multifunction type TRDU time delay relay with dip-switch function setting with 12Vdc, 24Vac, 120Vac, 240Vac inputs as required or indicated or engineer approved equal.

D. Time Switch

1. Provide an electronic time switch with full-year control in a NEMA 3R enclosure. The switch shall incorporate a non-volatile memory that maintains programmed switching times for the life of the time switch. Provide a factory installed field replaceable lithium or alkaline battery for time keeping and calendar information for a minimum of 8 years. Furnish with one single-pole, double-throw output switch rated 20-ampere at 240Vac. Furnish with manual override control.
 2. Manufacturer:
 - a. Intermatic Model ET70115CR or engineer approved equal.
 - b. Paragon Electric Company, Inc. EC71ST or engineer approved equal.
- E. Alternating Relay
1. Alternate assignment between “Duty” and “Stand-by” at the end of each run cycle.
 2. Double-pole, double-throw output relay rated for 7-amps inductive at 120-volts AC. Isolation not less than 1,500-volt RMS input to output. Life of 1,000,000 operations at full electrical load.
 3. Switch to select alteration or continuous operation of either load.
 4. Mount in Magnal 11-pin socket.
 5. Operating temperature range of –20 to +60-degree C.
 6. Manufacturer: ABB-SSAC type ARP series or Engineer accepted substitute.
- F. Motor Driven Timers – On-Delay and Off-Delay
1. Time Delay Relay - Upon Energization (TDE) or Upon De-Energization (TDDE): TDE driven by a 120Vac synchronous motor that starts timing when initiated by an external signal via closing a dry contact. Turn a knob on the front of the dial for time settings. TDE device will reset upon power failure. TDDE device will not reset upon power failure. Special configuration where specified: will not reset upon power failure.
 2. Provide a pilot light visible from the front of the timer to indicate when the timer motor is energized. Provide visual indication by a cycle progress pointer that advances to zero from the setting then back to zero as time progresses.
 3. Provide two of "instantaneous" NEMA Form-C output contacts that actuate when the timing is initiated. Provide two "delayed" NEMA Form-C contacts that actuate when the unit has timed out or de-energized. The timer automatically resets, when the timing cycle is completed. Contact ratings: 10-ampere at 120Vac and 5-ampere at 240Vac.
 4. Permanently mount and setup the timer with the initial settings shown or specified. Timer range with 16 configurations from 5-seconds to 60-hours. Range and timer set points shown on drawings.
 5. Timer Manufacturer: Eagle Cycle-Flex Automatic or Manual Reset Timer: HP5 series or HP5E series; Automatic Timing Controls, Series 305D Motor Driven Analog Reset; or engineer approved equal.

2.5 MAGNETIC CONTACTORS

A. Lighting Contactor

1. Provide 100 percent rated lighting contactors for ballast and tungsten lighting, resistance and other non-motor loads.
2. Provide contactor rated 600Vac, 60-Hertz with the ampere rating and number of poles as indicated on the drawings. Provide a minimum of two poles per NEMA ICS 2-211B for industrial-duty applications.

3. Provide the following options as indicated on the drawings:
 - a. Auxiliary contacts rated 5-amperes at 600Vac.
 - b. Timer or time clock attachment.
 - c. Transient suppression module for 120Vac control circuits.
 - d. Electrically or mechanically held as specified.
4. Provide contactors with disconnecting means and overcurrent protection mounted in the same enclosure.
5. Manufacturers:
 - a. Allen Bradley Bulletin 500L or 500LP
 - b. Square D Class 8903
 - c. ASCO 918 Remote Control with control module
 - d. Engineer approved equal.

B. Motor Contactors

1. Provide motor contactors designed for continuous operation of induction motors at 600Vac or less at 60-Hertz and in compliance with NEMA ICS 2-210. Unless otherwise specified or indicated, minimum contactor size shall be NEMA Size-1.
2. Supply motor contactors with a normally open auxiliary contact for use as a hold-in-contact and status contacts with a minimum of two additional Form-C contacts. Provide 120Vac coil voltage and 60-Hertz frequency with the number of poles and auxiliary contacts as indicated.
3. Manufacturer: GE, ABB, Allen Bradley, Square D, Eaton-Cutler Hammer or equal.
4. Provide solid-state overloads relays with one alarm contact. Where specified and shown as E-SSOL, provide the electronic SSOL relay: Automatic Timing and Controls (ATC) Motor Guardian for alarming and tripping on under-current, over-current, single-phase, ground-fault, motor-jam conditions. Provide ATC current transformers and voltage connections.
5. Manufacturer: ATC Lancaster, PA. Model: Motor Performance Analyzer; or engineer approved equal.

2.6 SAFETY DISCONNECT SWITCHES

1. Provide heavy-duty safety disconnect switches with 30-400-ampere ratings as indicated, circuit breaker operating or non-fused as indicated, stainless steel operator, safety type rated 600 volts AC.
2. Provide fusible disconnect switches with ratings as indicated with built-in fuse pullers. Provide LPS, LPN, or LPJ 200KAIC current limiting fuses as appropriate for the circuit type and the circuit voltage.
3. Enclosure locations and ratings:
 - a. Indoor enclosures: NEMA 12
 - b. Outdoor or corrosive areas: NEMA 4X stainless steel
 - c. Hazardous areas: NEMA 7
 - d. Classified areas: Suitable for the specified classification.
4. Provide operating handle capable of being padlocked in the "off" position. The operator shall be a positive, quick-make, quick-break mechanism. Provide bolt-on hubs. Provide door lock. Provide nameplates with the equipment tag number,

equipment description, and power source as indicated on the drawings. Submit nameplate list.

5. Provide horsepower rated switches for motors which comply with NEMA KS-1. Provide switches with defeatable door interlocks that prevent the door from opening when the operating handle is in the "on" position. Switches shall have line terminal shields.
6. Manufacturer: ABB, Cutler-Hammer, General Electric, Square-D, or engineer approved equal.

2.7 OVERCURRENT PROTECTION

A. Circuit Breakers

1. Provide thermal magnetic, molded case type circuit breakers with the ampere rating as specified. Unless otherwise specified or indicated, circuit breaker interrupting rating shall be 22,000 amperes symmetrical.

2.8 ELAPSED TIME INDICATORS

- A. Provide elapsed time indicators that are panel mounted, non-resettable, 5.5-digit, hour indicator, rated 120Vac, 60-Hertz.

2.9 CURRENT TRANSFORMERS AND TRANSDUCERS

- A. Provide monitoring current transformers with 600Vac insulation and primary ampere rating as indicated with 5-ampere output.
- B. Provide AC current transducer for any one of the phase conductors of the power circuit to be installed through onboard toroid. Provide a loop-powered transducer with input rated from 0 to 50-ampere with 4-20mADC analog output scaled for the primary current of the current transformer. Provide zero and span adjustments.
- C. Manufacturer: ABB AC current transducer TCSA Series Loop Powered and mounting accessories, or engineer approved equal.
- D. Provide a DIN rail or back plate mounted AC current transducer that is a loop-powered transducer with input rated from 0 to 5-ampere and with 4-20mADC analog output scaled for the primary current of the current transformer.
- E. Manufacturer: ABB AC current transducer DCSC Series Loop Powered and mounting accessories, or engineer approved equal.

2.10 TERMINAL STRIPS, BLOCKS, AND DEVICES

- A. Power Wiring: Provide back plate mounted terminal strips rated at 600Vac.
- B. Control Wiring: Provide a DIN rail with spring powered contact rated at 300Vac 24 ampere with pluggable terminals.
- C. Terminal identification standard to the product provided.
- D. Manufacturer:
 1. Standard: Allen Bradley or engineer approved equal.
 2. Standard: DIN rail: Phoenix Contact, Weidmuller Z-Series, or engineer approved equal.

2.11 INTRUSION DEVICES

- A. The intrusion switch shall be wide-gap industrial grade magnetic door switch with maximum gap 2.5 inches between the sensing elements. The magnet element shall be mounted on the moving part of the door. The sensor switch shall close when the door is closed. The sensor switch shall open when the door is opened. Provide with appropriate mounting bracket for the entrance doors.
- B. Manufacturer: George Risk Industries - Series 4400 (800-445-5218), [http://www.grisk.com/security_products.htm] or engineer approved equal.
- C. The intrusion override key switches shall be access control type with mortise cylinder and 24Vdc single pole double throw (SPDT) maintained contacts.
- D. Manufacturer: Von Duprin SS-900 series, or engineer approved equal.

2.12 THERMOSTATS

- A. Provide line voltage type thermostats with motor current rated contact and 70-degree to 140-degree Fahrenheit set point range.
- B. Manufacturer: Honeywell T631A-1022 or engineer approved equal.

2.13 STATIC GROUND INDICATOR

- A. Provide a static ground indicator and interlock system for verification of static ground connection to plant equipment, tanker trucks, drums, containers with flammable liquids or powders that are transferred and requiring effective grounding and bonding.
- B. Provide an explosion proof controller that meets NFPA 77 requirements with an intrinsically safe monitoring circuit that verifies a low resistant ground connection and dissipation path to ground. Product shall include an indicator light and interlock enabling product transfer and shall be rated for 120Vac power circuit.
- C. Manufacturer: Earth-Rite Plus with Hytrel Cable and Ground Clamp or engineer approved equal.

2.14 NAMEPLATES

- A. Nameplates for all control stations, relays, timers, motor contactors and disconnect switches shall be provided in accordance with the requirements of Section 26 00 01.

PART 3 EXECUTION

3.1 GENERAL

- A. Mount control stations, contactors and safety disconnect switches 48 inches above the floor, ground, or slab to center of device.
- B. Test miscellaneous electrical devices shall be tested in accordance with Section 26 00 01.

3.2 CONDUIT INSTALLATION

- A. See Section 26 05 33.13 – Conduit

3.3 CUTTING AND PATCHING

- A. Provide all cutting and patching required to perform this work.
- B. Do not cut into any major structural element without approval of Engineer.
- C. Provide patching of quality equal to, and of appearance matching, existing construction.

3.4 EQUIPMENT MOUNTING

- A. Wherever any electrical component, such as panels, raceways, pipes and conduits, will be in contact with surfaces which may become damp or wet, mount using spacers to hold electrical work $\frac{1}{4}$ inch away from damp surfaces.

END OF SECTION

SECTION 26 05 19

WIRE AND CABLE

PART 1 GENERAL

1.1 SUMMARY

A. Section Includes

<u>Paragraph</u>	<u>Title</u>
1.2	References
1.3	Submittals
1.4	Quality Assurance
1.5	Delivery, Storage, and Handling
1.6	Sizing of Conductors
1.7	Warranty
2.1	Conductors – General
2.2	Conductors 600 Volts and Below
2.3	Conductors above 600 Volts
2.4	600-Volt Rated Cable
2.5	Grounding Conductors
2.6	Accessories for Conductors 600 Volts and Below
2.7	Accessories for Conductors above 600 Volts
2.8	Pulling Compound
2.9	Source Quality Control
3.1	General
3.2	Power Conductor Color Coding
3.3	Circuit Identification
3.4	Conductors 600 Volts and Below
3.5	Conductor above 600 Volts
3.6	Conductor Arc and Fireproofing
3.7	Underground Direct Burial Cable
3.8	Testing

B. Scope

1. Work covered by this section includes furnishing all labor, equipment, and materials required to install, connect, and test all wire and cable, including splices, terminations, connectors, and accessories for a complete installation as shown on the Drawings and/or specified herein.
2. The Contractor's attention is directed to the fact that all wires and cables are not necessarily shown on the Drawings, which are more or less schematic. However, the Contractor shall be responsible for furnishing and installing all wire and cable indicated

or required to properly connect and place into operation all equipment and services requiring such wiring and/or cable.

1.2 REFERENCES

A. Reference Standards

1. The Association of Edison Illuminating Companies (AEIC): CS 8, Specification for Extruded Dielectric Shielded Power Cables Rated 5kV through 46 kV.
2. ASTM International (ASTM)
 - a. A167 – Standard Specification for Stainless and Heat-Resisting Chromium-Nickel Steel Plate, Sheet, and Strip
 - b. B33 – Standard Specification for Soft or Annealed Copper Wire
 - c. B8 – Standard Specification for Concentric-Lay-Stranded Copper Conductors, Hard, Medium-Hard, or Soft
 - d. B496 – Standard Specification for Compact Round Concentric-Lay-Stranded Copper Conductors
3. Insulated Cable Engineer's Association (ICEA)
 - a. S-58-679 – Standard for Control Cable Conductor Identification
 - b. S-73-532 – Standard for Control Cables
 - c. T-29-520 – Conducting Vertical Cable Tray Flame Tests with Theoretical Heat Input of 210,000 Btu/hour
4. Institute of Electrical and Electronics Engineers, Inc. (IEEE)
 - a. 48 – Standard Test Procedures and Requirements for High-Voltage Alternating-Current Cable Terminations 2.5 kV through 765 kV
 - b. 386 – Separable Insulated Connector Systems for Power Distribution Systems above 600V
 - c. 404 – Standard for Extruded and Laminated Dielectric Shielded Cable Joints Rated 2500 V to 500000 V
5. National Electrical Manufacturer's Association (NEMA)
 - a. CC 1 – Electric Power Connectors for Substations
 - b. WC 57 – Standard for Control, Thermocouple Extension, and Instrumentation Cables – ICEA S-73-532
 - c. WC 70 – Standard for Nonshielded Power Cables Rated 2000 Volts or Less for the Distribution of Electrical Energy
 - d. WC 71 – Standard for Nonshielded Power Cables Rated 2001 – 5000 Volts for Use in the Distribution of Electrical Energy
 - e. WC 74 – 5-46 kV Shielded Power Cable for Use in the Transmission and Distribution of Electrical Energy
6. National Fire Protection Association (NFPA)
 - a. 70 – National Electric Code (NEC)
 - b. 262 – Method of Test for Flame Travel and Smoke of Wires and Cables for Use in Air-Handling Spaces
7. Underwriters Laboratories Inc. (UL)
 - a. 13 – Standard for Safety Power-Limited Circuit Cables

- b. 44 – Standard for Safety Thermoset-Insulated Wires and Cables
- c. 62 – Standard for Safety Flexible Cord and Cables
- d. 486A-486B – Wire Connectors
- e. 486C – Standard for Splicing Wire Connections
- f. 510 – Standard for Safety Polyvinyl Chloride, Polyethylene, and Rubber Insulating Tape
- g. 854 – Standard for Safety Service-Entrance Cables
- h. 1072 – Standard for Safety Medium-Voltage Power Cables
- i. 1277 – Standard for Safety Electrical Power and Control Tray Cables with Optional Optical-Fiber Members
- j. 1569 – Metal Clad Cables
- k. 1581 – Standard for Safety Reference Standard for Electrical Wires, Cables, and Flexible Cords

1.3 SUBMITTALS

A. Action Submittals/Informational Submittals

1. Product Data

- a. Wire and cable descriptive product information.
- b. Wire and cable accessories descriptive product information.
- c. Cable Pulling Calculations:
 - 1) Submit calculations for review before cable installation.
 - 2) Provide cable pulling calculations for the following cable installations:
 - a) Medium voltage cable runs that cannot be hand pulled.
 - b) Multi-conductor 600-volt cable sizes larger than #2 AWG that cannot be hand pulled.

2. Test and Evaluation Reports

- a. Factory test report per AEIC CS 6, including AEIC qualification report for conductors above 600 volts.

1.4 QUALITY ASSURANCE

A. Authority Having Jurisdiction (AHJ)

- 1. Provide the work in accordance with NFPA 70. Where required by the AHJ, use material and equipment labeled or listed by a nationally recognized testing laboratory or other organization acceptable to the AHJ in order to provide a basis for approval under NEC.
- 2. Provide materials and equipment manufactured within the scope of standards published by Underwriters Laboratories Inc., which conforms to those standards and has an applied UL listing mark.

B. Qualifications

1. Installers/Applicators/Erectors

- a. Have Journeyman Lineman with splicing credentials perform terminations and splices for conductors above 600 Volts.

C. Field Samples

1. Submit samples of all wire and cable, clearly marked and long enough to show complete identification, to the office of the Engineer for approval prior to wiring installation.
2. Do not use defective or damaged wire and cable in the work.

1.5 DELIVERY, STORAGE, AND HANDLING

A. Storage and Handling Requirements

1. Store and protect all wire and cable in accordance with the manufacturer's recommendations and requirements of Section 01 66 00 – Storage and Protection.
2. Store wire and cable indoors in a dry and warm location and in its original packaging.

1.6 SIZING OF CONDUCTORS

A. Unless otherwise required or directed by the Engineer, furnish conductors in the sizes shown on the Drawings. Minimum wire sizing is as follows:

1. Lighting and Power: No. 12 AWG.
2. Motor Control Circuits Carrying Less Than 8 Amps: No. 14 AWG.
3. Instrumentation and Low-Level Signal Transmission Pairs: No. 16 AWG for single pairs or No. 20 AWG for bundled cable.

B. Size all wires and cables to conform to the regulations of the current edition of the National Electrical Code for current carrying capacity.

C. Where the size of lighting wiring is not given on the Drawings, provide wire of such size that the voltage drop from the main panel to the lighting panel is not more than 1 percent, and the drop in the branch circuit is not more than 2 percent. The voltage drop in motor feeder, when the wire size is not specified, shall not be more than 3 percent at full load from the Motor Control Center to the motor terminal.

1.7 WARRANTY

A. Provide a guarantee against defective materials and workmanship in accordance with requirements of Section 01 78 33 – Warranties and Bonds.

PART 2 PRODUCTS

2.1 CONDUCTORS – GENERAL

- A. Conductors: Solid or Class B concentric stranded, soft or annealed, uncoated copper, free from kinks and defects in accordance with ASTM B3 or B8.
- B. Conductivity: Not less than 97 percent.
- C. Insulation Thickness: Not less than that specified by the National Electrical Code.
- D. Provide wire and cable with the size, grade of insulation, voltage, and manufacturer's "E-Number" permanently marked on the outer covering at not more than 2-foot intervals.
- E. Provide all wires conforming to the latest Standards of the ASTM and ICEA, which are tested for their full length by these Standards.
- F. Provide stranded wiring for all control circuit wiring and all wiring No. 8 AWG and larger. Lighting branch circuits No. 12 and No. 10 AWG may be solid. Wiring shall be stranded as follows:
 1. No. 14 thru No. 2 AWG: Minimum of 7 strands.

2. No. 1 thru No. 4/0 AWG: Minimum of 19 strands.
3. No. 250 MCM thru No. 500 MCM: Minimum of 37 strands.
4. Provide all circuits, except control and instrumentation circuits, with a separate grounding conductor carried in the conduit.

2.2 CONDUCTORS 600 VOLTS AND BELOW

- A. Conform to applicable requirements of NEMA WC 70.
- B. Conductor Type
 1. 120-Volt and 277-Volt Lighting, 10 AWG and Smaller: Solid Copper.
 2. 120-Volt Receptacle Circuits, 10 AWG and Smaller: Solid Copper.
 3. All other Circuits: Stranded.
- C. Insulation: Type THHN/THWN-2, except for sizes No. 6 and larger, with XHHW-2 insulation.
- D. Direct Burial and Aerial Conductors and Cables
 1. Type USE/RHH/RHW insulation, UL 854 listed, or Type RHW-2/USE-2.
 2. Conform to physical and minimum thickness requirements of NEMA WC 70.
- E. Flexible Cords and Cables
 1. Type SOW-A/50 with ethylene-propylene rubber insulation in accordance with UL 62.
 2. Conform to physical and minimum thickness requirements of NEMA WC 70.

2.3 CONDUCTORS ABOVE 600 VOLTS

- A. EPR Insulated Cable
 1. Extrusion: Single-pass, triple-tandem, of conductor screen, insulation, and insulation screen.
 2. Type 5, shielded UL 1072, Type MV-105.
 3. Conductors: Copper, concentric lay Class B round stranded in accordance with ASTM B3, ASTM B8, and ASTM B496.
 4. Strand Fill: Waterproof strand compound enclosing all conductors.
 5. Conductor Screen: Extruded, semiconducting ethylene-propylene rubber in accordance with NEMA WC 71 and AEIC CS 8.
 6. Insulation: 133 percent insulation level, ethylene-propylene rubber, containing no polyethylene in accordance with NEMA WC 71 and AEIC CS 8.
 7. Insulation Thickness: 115-mil, 5kV, nominal.
 8. Insulation Screen: Thermosetting, semiconducting ethylene-propylene rubber, extruded directly over insulation in accordance with NEMA WC 71 and AEIC CS 8.
 9. Metallic Shield: Uncoated, 5-mil, copper shielding tape, helically applied with 12-1/2 percent minimum overlap.
 10. Jacket: Extruded polyvinyl chloride (PVC) compound applied over the metallic shield in accordance with NEMA WC 71.
 11. Operating Temperature: 105 degrees C continuous normal operations, 130 degrees C emergency operating conditions, and 250 degrees C short-circuit conditions.

12. Manufacturers:
 - a. Okonite Co.
 - b. Pirelli Wire and Cable.
 - c. Southwire Co.
 - d. General Cable.
 - e. Engineer approved equal.

2.4 600-VOLT RATED CABLE

A. General

1. Type TC, meeting requirements of UL 1277, including Vertical Tray Flame Test at 70,000 Btu per hour, and NFPA 70, Article 340, or UL 13 meeting requirements of NFPA 70, Article 725.
2. Permanently and legibly marked with manufacturer's name, maximum working voltage for which cable was tested, type of cable, and UL listing mark.
3. Suitable for installation in open air, in cable trays, or conduit.
4. Minimum Temperature Rating: 90 degrees C dry locations, 75 degrees C wet locations.
5. Overall Outer Jacket: PVC, flame-retardant, sunlight- and oil- resistant.

B. Multi-Conductor Power Cable

1. General
 - a. Meet or exceed UL 1581 for cable tray use.
 - b. Meet or exceed UL 1277 for direct burial and sunlight-resistance.
 - c. Overall Jacket: PVC.
2. Conductors
 - a. Class B stranded, coated copper.
 - b. Insulation: Chemically cross-linked ethylene-propylene or cross-linked polyethylene.
 - c. UL Rated VW-1 or listed Type XHHW-2.
 - d. Color Code:
 - 1) Conductors, size 8 AWG and smaller, colored conductors, ICEA S-58-679, Method 1, Table 1.
 - 2) Conductors size 6 AEG and larger, ICEA S-73-532, Method 4.
3. Passes ICEA T-29-520, 210,000 Btu per hour Vertical Tray Flame Test.
4. Manufacturers
 - a. Okonite Co.
 - b. Southwire Co.
 - c. Engineer approved equal.

C. Multi-Conductor Control Cable

1. Conductors
 - a. 14 AWG, seven-strand copper.

- b. Insulation: 15-mil PVC with 4-mil nylon.
 - c. UL 1581 listed as Type THHN/THWN rated VW-1.
 - d. Conductor group bound with spiral wrap of barrier tape.
 - e. Color Code: In accordance with ICEA S-58-679, Method 1, Table 2.
2. Passes ICEA T-29-520, 210,000 Btu per hour Vertical Tray Flame Test.
 3. Manufacturers
 - a. Okonite Co.
 - b. Southwire Co.
 - c. Engineer approved equal.
- D. Multi-Conductor Adjustable Frequency Drive Power Cable
1. Conductors
 - a. Class B stranded, coated copper.
 - b. Insulation: 600-Volt cross-linked polyethylene, UL Type XHHW-2.
 - c. Grounding Conductors: Insulated stranded copper.
 2. Sheath
 - a. UL 1277 Type TC, 90 degree C.
 - b. Continuous shield, Al/polyester foil, drain wires, overall copper braid.
 3. Outer Jacket: Polyvinyl chloride (PVC) per UL 1569.
 4. Manufacturers
 - a. Alpha Wire, Series V.
 - b. Belden, Series 29500.
 - c. LAPP USA, OLFLEX VFD Slim.
 - d. Engineer approved equal.
- E. Multi-Conductor Metal-Clad (UL Type MC) Power Cable for Adjustable Frequency Drive Applications
1. Meeting requirements of UL 44 and UL 1569.
 2. Conductors
 - a. Class B stranded, coated copper.
 - b. Insulation: 600-Volt cross-linked polyethylene, UL Type XHHW or EPR.
 - c. Grounding Conductors: Bare stranded copper. Provide three symmetrical grounding conductors.
 3. Sheath
 - a. UL listed Type MC.
 - b. Continuous welded, corrugated aluminum sheath.
 - c. Suitable for use as grounding conductor.
 4. Outer Jacket: Polyvinyl chloride (PVC) per UL 1569.
 5. Passes ICEA T-29-520, 210,000 Btu per hour Vertical Tray Flame Test.
 6. Manufacturers
 - a. Okonite Co., Type CLX MC-HL.

- b. Engineer approved equal.
- F. 16 AWG Twisted, Shielded Pair, Instrumentation Cable: Single pair, designed for noise rejection for process control, computer, or data log applications meeting NEMA WC 57 requirements.
- 1. Outer Jacket: 45-mil nominal thickness.
 - 2. Individual Pair Shield: 1.35-mil, double-faced aluminum/synthetic polymer overlapped to provide 100 percent coverage.
 - 3. Dimension: 0.31-inch nominal OD.
 - 4. Conductors
 - a. Bare soft annealed copper, Class B, seven-strand concentric, meeting requirements of ASTM B8.
 - b. 20 AWG, seven-strand tinned copper drain wire.
 - c. Insulation: 15-mil nominal PVC.
 - d. Jacket: 4-mil nominal nylon.
 - e. Color Code: Pair conductors, black and red.
 - 5. Manufacturers
 - a. Okonite Co.
 - b. Alpha Wire Corp.
 - c. Belden.
 - d. Engineer Approved equal.
- G. 16 AWG Twisted, Shielded Pair, Triad Instrumentation Cable: Single triad, designed for noise rejection for process control, computer, or data log applications meeting NEMA WC 57 requirements.
- 1. Outer Jacket: 45-mil nominal thickness.
 - 2. Individual Pair Shield: 1.35-mil, double-faced aluminum/synthetic polymer overlapped to provide 100 percent coverage.
 - 3. Dimension: 0.32-inch nominal OD.
 - 4. Conductors
 - a. Bare soft annealed copper, Class B, seven-strand concentric, meeting requirements of ASTM B8.
 - b. 20 AWG, seven-strand tinned copper drain wire.
 - c. Insulation: 15-mil nominal PVC.
 - d. Jacket: 4-mil nominal nylon.
 - e. Color Code: Triad conductors, black, red, and blue.
 - 5. Manufacturers
 - a. Okonite Co.
 - b. Alpha Wire Corp.
 - c. Belden.
 - d. Engineer approved equal.

H. 18 AWG Multi-Twisted, Shielded Pairs with a Common Overall Shield Instrumentation Cable: Designed for use as instrumentation, process control, and computer cable meeting NEMA WC 57 requirements.

1. Conductors

- a. Bare soft annealed copper, Class B, seven-strand concentric, meeting requirements of ASTM B8.
- b. Tinned copper drain wires.
- c. Pair drain wire size AWG 20, group drain wire size AWG 18.
- d. Insulation: 15-mil nominal PVC.
- e. Jacket: 4-mil nominal nylon.
- f. Color Code: Pair conductors, black and red with red conductor numerically printed for group identification.
- g. Individual Pair Shield: 1.35-mil, double-faced aluminum/synthetic polymer.

2. Cable Shield: 2.35-mil, double-faced aluminum/synthetic polymer overlapped for 100 percent coverage.

3. Manufacturers

- a. Okonite Co.
- b. Alpha Wire Corp.
- c. Belden.
- d. Engineer approved equal.

2.5 GROUNDING CONDUCTORS

- A. Equipment: Stranded copper with green, Type USE/RHH/RHW-XLPE or THHN/THWN insulation.
- B. Direct Buried: Bare stranded copper.

2.6 ACCESSORIES FOR CONDUCTORS 600 VOLTS AND BELOW

A. Tape

1. General Purpose, Flame Retardant: 7-mil, vinyl plastic, Scotch Brand 33+, rated for 90 degrees C minimum, meeting requirements of UL 510.
2. Flame Retardant, Cold and Weather Resistant: 8.5-mil vinyl plastic, Scotch Brand 88.
3. Arc and Fire Proofing
 - a. 30-mil, elastomer.
 - b. Manufacturers
 - 1) 3M; Scotch Brand 77, with Scotch Brand 69 glass cloth tape binder.
 - 2) Plymouth; 53 Plyarc, with 77 Plyglas glass cloth tape binder.
 - 3) Engineer approved equal.

B. Identification Devices

1. Sleeve

- a. Permanent, PVC, yellow or white, with legible machine-printed black markings.
- b. Manufacturers

- 1) Raychem; Type D-SCE or ZH-SCE.
 - 2) Brady, Type 3PS.
 - 3) Engineer approved equal.
2. Heat Bond Marker
 - a. Transparent thermoplastic heat bonding film with acrylic pressure sensitive adhesive.
 - b. Self-laminating protective shield over text.
 - c. Machine-printed black text.
 - d. Manufacturer: 3m Co.; Type SCS-HB, or Engineer approved equal.
 3. Marker Plate: Nylon, with legible designation permanently hot stamped on plate.
 4. Tie-On Cable Marker Tags
 - a. Chemical-resistant white tag.
 - b. Size: ½-inch by 2 inches.
 - c. Manufacturer: Raychem; Type CM-SCE, or Engineer approved equal.
 5. Grounding Conductor: Permanent green heat-shrink sleeve, 2-inch minimum.
- C. Connectors and Terminations
1. Nylon, Self-Insulated Crimp Connectors
 - a. Manufacturers
 - 1) Thomas & Betts; Sta-Kon
 - 2) Burndy; Insulug.
 - 3) ILSCO.
 - 4) Engineer approved equal.
 2. Nylon, Self-Insulated Crimp Locking-Fork, Torque-Type Terminator
 - a. Suitable for use with 75 degree C wire at full NFPA 70, 75 degree C ampacity.
 - b. Seamless.
 - c. Manufacturers
 - 1) Thomas & Betts; Sta-Kon
 - 2) Burndy; Insulink.
 - 3) ILSCO; ILSCONS.
 - 4) Engineer approved equal.
 3. Self-Insulated, Freespring Wire Connector (Wire Nuts)
 - a. UL 486C.
 - b. Plated steel, square wire springs.
 - c. Manufacturers
 - 1) Thomas & Betts.
 - 2) Ideal; Twister.
 - 3) Engineer approved equal.
 4. Self-Insulated, Set Screw Wire Connector

- a. Two piece compression type set screw in brass barrel.
 - b. Insulated by insulator cap screw over brass barrel.
 - c. Manufacturers
 - 1) 3M Co.
 - 2) Thomas & Betts.
 - 3) Marrette.
 - 4) Engineer approved equal.
- D. Cable Lugs
- 1. In accordance with NEMA CC 1.
 - 2. Rated 600 volts of same material as conductor metal.
 - 3. Uninsulated Crimp Connectors and Terminators
 - a. Suitable for use with 75 degree C wire at full NFPA 70, 75 degree C ampacity.
 - b. Manufacturers
 - 1) Thomas & Betts; Color-Keyed
 - 2) Burndy; Hydent.
 - 3) ILSCO.
 - 4) Engineer approved equal.
 - 4. Uninsulated, Bolted, Two-way Connectors and Terminators
 - a. Manufacturers
 - 1) Thomas & Betts; Locktite
 - 2) Burndy; Quiklug.
 - 3) ILSCO.
 - 4) Engineer approved equal.
- E. Cable Ties
- 1. Nylon, adjustable, self-locking, and reusable.
 - 2. Manufacturers: Thomas & Betts; TY-RAP, or Engineer approved equal.
- F. Heat Shrinkable Insulation
- 1. Thermally stabilized cross-linked polyolefin.
 - 2. Single wall for insulation and strain relief.
 - 3. Dual Wall, adhesive sealant lined, for sealing and corrosion resistance.
 - 4. Manufacturers
 - a. Thomas & Betts; SHRINK-KON.
 - b. Raychem; RNF-100 and ES-2000.
 - c. Engineer approved equal.
- G. Data Cable Accessories: Terminators, connectors, and junctions necessary for a complete DeviceNet system.

2.7 ACCESSORIES FOR CONDUCTORS ABOVE 600 VOLTS

A. Molded Splice Kits

1. Components necessary to provide insulation, metallic shielding and grounding systems, and overall jacket.
2. Capable of making splices with a current rating equal to or greater than the cable ampacity, conforming to IEEE 404.
3. Class 5 kV, with compression connector, EPDM molded semiconductive insert, peroxide-cured EPDM insulation, and EPDM molded semiconductive outer shield.
4. Premolded splice shall be rejaacketed with a heat shrinkable adhesive-lined sleeve to provide a waterproof seal.
5. Manufacturers
 - a. Elastimold.
 - b. Cooper Industries.
 - c. Engineer approved equal.

B. Heat Shrinkable Splice Kits

1. Components necessary to provide insulation, metallic shielding and grounding systems, and overall jacket.
2. Capable of making splices with a current rating equal to or greater than the cable ampacity, conforming to IEEE 404.
3. Class 5 kV, with compression connector, splice insulating and conducting sleeves, stress-relief materials, shielding braid and mesh, and abrasion-resistant heat shrinkable adhesive-lined rejaacketing sleeve to provide a waterproof seal.
4. Manufacturers
 - a. Raychem.
 - b. 3M Co.
 - c. Engineer approved equal.

C. Termination Kits

1. Capable of terminating 5kV, single-conductor, polymeric-insulated shielded cables plus a shield ground clamp.
2. Capable of producing termination with a current rating equal to or greater than the cable ampacity meeting Class 1 requirements of IEEE 48.
3. Capable of accommodating any form of cable shielding or construction without the need for special adapters or accessories.
4. Manufacturers
 - a. Raychem.
 - b. 3M Co.
 - c. Engineer approved equal.

D. Bus Connection Insulation

1. Heat shrinkable tubing, tape, and sheets of flexible cross-linked polymeric material formulated for high dielectric strength.
2. Tape and sheet products to have coating to prevent adhesion to metal surfaces.
3. Insulating materials to be removable and reusable.

4. Manufacturers: Raychem, or Engineer approved equal.
- E. Elbow Connector Systems
1. Molded, peroxide-cured, EPDM-insulated, Class 15 kV, 95 kV BIL, 200A, 15,000 rms nonload-break and 600A, 40,000 rms nonload-break elbows having all copper current-carrying parts in accordance with IEEE 386.
 2. Protective Caps: Class 15 kV, 95 kV BIL, 600 amperes, with molded EPDM insulated body.
 3. Insulated Standoff Bushing: Class 15 kV, 95 kV BIL, 200 and 600 amperes, complete with EPDM rubber body, stainless steel eyebolt with brass pressure foot, and stainless steel base bracket.
 4. Bushing Insert: Class 15 kV, 95 kV BIL, 600A, nonload-break, with EPDM rubber body and all copper, current carrying parts.
 5. Junctions: Class 15kV, 95 kV two-way, 600A, nonload-break, having EPDM rubber body mounted on adjustable bracket.
 6. Mounting Plates: Two-way, ASTM A167 stainless steel, complete with universal mounting brackets, grounding lugs and two parking stands.
 7. Manufacturers
 - a. Cooper Industries.
 - b. Elastimold.
 - c. Engineer approved equal.
- F. Cable Lugs
1. In accordance with NEMA CC 1.
 2. Rated 5 kV of same material as conductor metal.
 3. Manufacturers, Uninsulated Compression Connectors and Terminators
 - a. Burndy; Hydent.
 - b. Thomas & Betts; Color-Keyed.
 - c. ILSCO.
 - d. Engineer approved equal.
 4. Manufacturers, Uninsulated, Bolted, Two-way Connectors and Terminators
 - a. Thomas & Betts; Locktite.
 - b. ILSCO.
 - c. Engineer approved equal.

2.8 PULLING COMPOUND

- A. Nontoxic, noncorrosive, noncombustible, nonflammable, water-based lubricant; UL listed.
- B. Suitable for rubber, neoprene, PVC, Polyethylene, hypalon, CPE, and lead-covered wire and cable.
- C. Approved for intended use by cable manufacturer.
- D. Suitable for zinc-coated steel, aluminum, PVC, bituminized fiber, and fiberglass raceways.
- E. Manufacturers
 1. Ideal Co.

2. Polywater Inc.
3. Cable Grip Co.
4. Engineer approved equal.

2.9 SOURCE QUALITY CONTROL

A. Tests and Inspections

1. Conductors 600 Volts and Below: Test in accordance with UL 44 and UL 854.
2. Conductors Above 600 Volts: Test in accordance with NEMA WC 71 and AEIC CS 6 partial discharge level test for EPR insulated cable.

PART 3 EXECUTION

3.1 GENERAL

- A. Install conductors in accordance with manufacturer's recommendations.
- B. Conductor and cable sizing shown is based on copper conductors, unless noted otherwise.
- C. Do not exceed cable manufacturer's recommendations for maximum pulling tensions and minimum bending radii.
- D. Terminate all conductors and cables, unless noted otherwise.
- E. Tighten screws and terminal bolts in accordance with UL 486A – 486B for copper conductors.
- F. Cable Lugs: Provide with correct number of holes, bolt size, and center-to-center spacing as required by equipment terminals.
- G. Bundling: Where single conductors and cables in manholes, handholes, vaults, cable trays, and other indicated locations are not wrapped together by some other means, bundle conductors from each conduit throughout their exposed length with cable ties placed at intervals not exceeding 18 inches on center.
- H. Ream, remove burrs, and clear interior of installed conduit before pulling wires or cables.
- I. Concrete-Encased Raceway Installation: Prior to installation of conductors, pull through each raceway a mandrel approximately 1/4-inch smaller than raceway inside diameter.
- J. Cable Tray Installation
 1. Install wire and cable parallel and straight in tray.
 2. Bundle, in groups, wire and cable of same voltage having common routing and destination; use cable ties, at maximum intervals of 8 feet.
 3. Clamp cable bundles prior to making end termination connections.
 4. Separate cables of different voltage rating in same cable tray with barriers.
 5. Fasten wires, cables, and bundles to tray with nylon cable straps at the following maximum intervals.
 - a. Horizontal Runs: 20 feet.
 - b. Vertical Runs: 5 feet.

3.2 POWER CONDUCTOR COLOR CODING

- A. Conductors 600 Volts and Below

1. 6 AWG and Larger: Apply general purpose, flame retardant tape at each end, and at accessible locations wrapped at least six full overlapping turns, covering an area 1-1/2 inches to 2 inches wide.
2. 8 AWG and Smaller: Provide colored conductors.
3. Colors

System	Conductor	Color
All Systems	Equipment Grounding	Green
240/120 Volts Single-Phase, Three-Wire	Grounded Neutral One Hot Leg Other Hot Leg	White Black Red
208/120 Volts Three-Phase, Four Wire	Grounded Neutral Phase A Phase B Phase C	White Black Red Blue
240/120 Volts Three-Phase, Four-Wire Delta, Center Tap Ground on Single-Phase	Grounded Neutral Phase A High (wild) Leg Phase C	White Black Orange Blue
480Y/277 Volts Three-Phase, Four-Wire	Grounded Neutral Phase A Phase B Phase C	White Brown Orange Yellow

4. Tracer: Outer covering of white with an identifiable colored strip, other than green, in accordance with NFPA 70.
- B. Conductors Above 600 Volts: Apply general purpose, flame retardant tape at each end, and at accessible locations wrapped at least six full overlapping turns, covering an area 1-1/2 inches to 2 inches wide.
1. Colors
 - a. Grounded Neutral: White.
 - b. Phase A: Brown.
 - c. Phase B: Orange.
 - d. Phase C: Yellow.

3.3 CIRCUIT IDENTIFICATION

- A. Identify power, instrumentation, and control conductor circuits at each termination, and in accessible locations such as manholes, handholes, panels, switchboards, motor control centers, pull boxes, and terminal boxes.
- B. Circuits Appearing in Circuit Schedules: Identify using circuit schedule designations.
- C. Circuits Not Appearing in Circuit Schedules
 1. Assign circuit name based on device or equipment at load end of circuit.
 2. Where this would result in same name being assigned to more than one circuit, add number or letter to each otherwise identical circuit name to make it unique.
- D. Method
 1. Conductors 3 AWG and Smaller: Identify with sleeves or heat bond markers.
 2. Cables and Conductors 2 AWG and Larger

- a. Identify with marker plates or tie-on cable marker tags.
 - b. Attach with nylon tie cord.
3. Do not use taped-on markers or tags relying on adhesives.

3.4 CONDUCTORS 600 VOLTS AND BELOW

- A. Install 10 AWG or 12 AWG conductors for branch circuit power wiring in lighting and receptacle circuits.
- B. Do not splice incoming service conductors and branch power distribution conductors 6 AWG and larger, unless specifically indicated or approved by Engineer.
- C. Connections and Terminations
 1. Install wire nuts only on solid conductors. Wire nuts are not allowed on stranded conductors.
 2. Install nylon self-insulated crimp connectors and terminators for instrumentation and control circuit conductors.
 3. Install self-insulated, set screw wire connectors for two-way connection of power circuit conductors 12 AWG and smaller.
 4. Install uninsulated crimp connectors and terminators for instrumentation, control, and power circuit conductors 4 AWG through 2/0 AWG.
 5. Install uninsulated, bolted, two-way connectors and terminators for power circuit conductors 3/0 AWG and larger.
 6. Install uninsulated terminators bolted together on motor circuit conductors 10 AWG and larger.
 7. Place no more than one conductor in any single-barrel pressure connection.
 8. Install crimp connectors with tools approved by connector manufacturer.
 9. Install terminals and connectors acceptable for type of material used.
 10. Compression Lugs:
 - a. Attach with a tool specifically designed for purpose. Tool shall provide complete, controlled crimp and shall not release until crimp is complete
 - b. Do not use plier type crimpers.
- D. Do not use soldered mechanical joints.
- E. Splices and Terminations
 1. Insulate all uninsulated connections.
 2. Indoors: Use general purpose, flame retardant tape or single wall heat shrink.
 3. Outdoors, Dry Locations: Use flame retardant, cold- and weather-resistant tape or single wall heat shrink.
 4. Below Grade and Wet or Damp Locations: Use dual wall heat shrink.
- F. Cap spare conductors with UL listed end caps.
- G. Cabinets, Panels, and Motor Control Centers
 1. Remove surplus wire, braid and secure.
 2. Where conductors pass through openings or over edges in sheet metal, remove burrs, chamfer edges, and install bushings and protective strips of insulating material to protect the conductors.

H. Control and Instrumentation Wiring

1. Where terminals provided will accept such lugs, terminate control and instrumentation wiring, except solid thermocouple leads, with insulated, locking-fork compression lugs.
2. Terminate with methods consistent with terminals provided and in accordance with terminal manufacturer's instructions.
3. Locate splices in readily accessible cabinets or junction boxes using terminal strips.
4. Where connections of cables installed under this section are to be made under Section 40 90 01 – General Requirements for Instrumentation and Control.
5. Cable Protection:
 - a. Under Infinite Access Floors: May install without bundling.
 - b. All Other Areas: Install individual wires, pairs, or triads in flex conduit under floor or grouped into bundles at least ½-inch in diameter.
 - c. Maintain integrity of shielding of instrumentation cables.
 - d. Ensure grounds do not occur because of damage to jacket over the shield.
- I. Extra Conductor Length: For conductors to be connected by others, install minimum 6 feet of extra conductor in free standing panels and minimum 2 feet in other assemblies.

3.5 CONDUCTORS ABOVE 600 VOLTS

- A. Do not splice.
- B. Make joints and terminations with termination kits, in accordance with kit manufacturer's instructions.
- C. Install terminations as continuous operation in accessible locations under clean, dry conditions.
- D. Single Conductor Cable Terminations: Provide heat shrinkable stress control and outer nontracking insulation tubings, high relative permittivity stress relief mastic for insulation shield cutback treatment, and a heat-activated sealant for environmental sealing, plus a ground braid and clamp.
- E. Install terminals or connectors acceptable for type of conductor material used.
- F. Provide outdoor rain skirts for riser pole and outdoor switchgear terminations.
- G. Provide shield termination and grounding for terminations.
- H. Provide necessary mounting hardware, covers, and connectors.
- I. Where elbow connectors are specified, install in accordance with Manufacturer's instructions.
- J. Connections and Terminations
 1. Install uninsulated crimp connectors and terminators for power conductors 4 AWG through 2/0 AWG.
 2. Install uninsulated, bolted, two-way connectors and terminators for power circuit conductors 4/0 AWG and larger.
 3. Install uninsulated, bolted, two-way connectors for motor circuit conductors No. 12 and larger.
 4. Insulate bus connections with heat shrinking tubing, tape, and sheets.
 5. Make bus connections removable and reusable in accordance with manufacturer's instructions.

K. Give two (2) working days notice to Engineer prior to making splices or terminations.

3.6 CONDUCTOR ARC AND FIREPROOFING

- A. Install arc and fire proofing tape on 5 kV cables throughout their entire exposed length in manholes, handholes, vaults, cable trays, and other indicated locations.
- B. Wrap conductors of same circuit entering from separate conduit together as a single cable.
- C. Follow tape manufacturer's installation instructions.
- D. Secure tape at intervals of 5 feet with bands of tape binder. Each band to consist of a minimum of two wraps directly over each other.

3.7 UNDERGROUND DIRECT BURIAL CABLE

- A. Install in trench as specified in Section 31 23 00 – Excavation and Fill.
- B. Warning Tape: Install approximately 6 inches above cable, aligned parallel to, and within 12 inches of centerline of the run.

3.8 TESTING

- A. Perform visual and mechanical inspection of each individual exposed power cable 6 AWG and larger for physical damage, correct terminations in accordance with the Drawings, cable bends in accordance with bending radius requirements, proper circuit identification, proper lug type, tightness of bolted connections with proper torque level per NETA ATS, Table 10.12 or manufacturer's specifications, and proper grounding.
- B. Perform Insulation Resistance Testing of all conductors 6 AWG and larger with respect to ground and each adjacent conductor. Apply 1,000 volts DC for one minute on 600 volts insulated conductors in accordance with NETA. Minimum insulation resistance values shall not be less than 50 meg-ohms. Investigate all deviations between adjacent phases.
- C. Perform Continuity Test by ohmmeter method to ensure proper cable connection of all conductors 6 AWG and larger.
- D. Keep a written record of all insulation tests on forms approved for the purpose. These forms shall show the number or other suitable identification of each circuit or piece of apparatus tested, the date of the test, the temperature at the time the test was made, the instrument used, the test voltage applied, the resistance values found, and the name of the person in charge of and witnessing the test.

END OF SECTION

SECTION 26 05 26

GROUNDING

PART 1 GENERAL

1.1 SUMMARY

A. Section Includes

<u>Article</u>	<u>Title</u>
1.2	References
1.3	Submittals
2.1	Ground Conductors
2.2	Ground Rods
2.3	Compression Connectors
2.4	Bolted Connectors
2.5	Welded Connectors
2.6	Test Wells
2.7	Equipment Ground Bars
2.8	Equipment Ground Plate
2.9	Product Data
3.1	General
3.2	Raceway Ground
3.3	Equipment and Enclosure Bonding
3.4	Isolated Grounding
3.5	Service and Separately Derived System Bonding
3.6	Grounding System Tests

B. Scope

1. This section specifies the system for grounding electrical distribution and utilization equipment, including but not limited to cabinets, motor frames, manholes, instrumentation, metal surfaces of process/mechanical equipment that contain energized electrical components, metal structures and buildings, outdoor metal enclosures, fences and gates.
2. Provide Equipment Grounding Conductors to ground or bond equipment, structures, or equipment frames to the Grounding Electrode System as defined in the National Electrical Code Article 250 and addressed herein.
3. The minimum size of the Equipment Grounding Conductors installed with the circuit conductors shall be per the National Electrical Code Table 250.122. The circuit grounding conductor size routed with a feeder or branch circuit conductors is as shown on the drawings.

1.2 REFERENCES

A. Reference Standards

1. This section contains references to the following documents. They are a part of this section as specified and modified. Where a referenced document contains references to other standards, those documents are included as references under this section as if referenced directly. In the event of conflict between the requirements of this section and those of the listed documents, the requirements of this section shall prevail.
2. Unless otherwise specified, references to documents shall mean the documents in effect at the time of Advertisement for Bids or Invitation to Bid (or on the effective date of the Agreement if there were no Bids). If referenced documents have been discontinued by the issuing organization, references to those documents shall mean the replacement documents issued or otherwise identified by that organization or, if there are no replacement documents, the last version of the document before it was discontinued. Where document dates are given in the following listing, references to those documents shall mean the specific document version associated with that date, regardless of whether the document has been superseded by a version with a later date, discontinued or replaced.

Reference	Title
IEEE 81	Guide for Measuring Earth Resistivity, Ground Impedance, and Earth Surface Potentials of a Ground System
IEE Std 81.2-1991	Guide to Measurement of Impedance and Safety Characteristics of Large, Extended or Interconnected Grounding Systems
NETA - ATS	International Electrical Testing Association Inc. - Acceptance Testing Specifications
NFPA 70	National Electric Code (NEC) Article 250

1.3 SUBMITTALS

A. Action Submittals/Informational Submittals

1. Product Data

- a. Marked product literature for ground rods, test wells, and equipment ground plate.

2. Special Procedure Submittals

- a. A copy of this specification section, with addendum updates included, and all referenced and applicable sections, with addendum updates included, with each paragraph check-marked to indicate specification compliance or marked to indicate requested deviations from specification requirements. A check mark shall denote full compliance with a paragraph as a whole. If deviations from the specifications are indicated, and therefore requested by the Contractor, each deviation shall be underlined and denoted by a number in the margin to the right of the identified paragraph, referenced to a detailed written explanation of the reasons for requesting the deviation. The Engineer shall be the final authority for determining acceptability of requested deviations. The remaining portions of the paragraph not underlined will signify compliance on the part of the Contractor with the specifications. *Failure to include a copy of the marked-up specification sections, along with justification(s) for any requested deviations to the specification requirements, with the submittal shall be sufficient cause for rejection of the entire submittal with no further consideration.*

PART 2 PRODUCTS

2.1 GROUND CONDUCTORS

- A. Soft-drawn, bare annealed copper, concentric stranded, as specified.

B. Minimum sizes as follows, where American Wire Gage (AWG) conductor sizes are not shown or specified:

1. 5 and 15 kV switchgear	2/0 or 4/0 AWG
2. 5 kV motor starters	2/0 or 4/0 AWG
3. 15 kV-5 kV transformers	2/0 or 4/0 AWG
4. 5 kV-480V transformers	2/0 or 4/0 AWG
5. 480V switchgear	2/0 or 4/0 AWG
6. 480V switchboards	2/0 or 4/0 AWG
7. 480V MCC and	2/0 or 4/0 AWG
8. Cable tray	2/0 or 4/0 AWG
9. Large motors 250 hp & >	2/0 or 4/0 AWG
10. Lighting & Power panels	2 AWG
11. Exposed metal cabinets	2 AWG
12. Electrical equipment	2 AWG
13. Buildings and enclosure	2 AWG
14. Fences and gates	2 AWG
15. Motors 25 hp to 250 hp	2 AWG
16. Motors 1 hp to 25 hp	6 AWG

2.2 GROUND RODS

- A. Copper covered steel, 3/4-inch diameter and 10-feet long.
- B. Threaded type removable caps so that extension rods of same diameter and length may be added where necessary.

2.3 COMPRESSION CONNECTORS

- A. Irreversible, cast copper as manufactured by Thomas and Betts, or Engineer approved equal.

2.4 BOLTED CONNECTORS

- A. Burndy, O. Z. Gedney, or Engineer approved equal.

2.5 WELDED CONNECTORS

- A. Exothermic welding products shall be Erico's Cadweld Plus system with a remotely operated battery powered electronic ignition device and moisture resistant weld metal cup for the required mold, or Engineer approved equal.

2.6 TEST WELLS

- A. Provide concrete test well with cover and connect the ground grid extension using a removable connector.

2.7 EQUIPMENT GROUND BARS

- A. Copper bars, Erico Eritech EGB Series or Engineer approved equal.
- B. Sized as required for the installation.

2.8 EQUIPMENT GROUND PLATE

- A. Two-hole copper flush mounted grounding plate, Erico Cadweld, Burndy YGF Series, or Engineer approved equal.

2.9 PRODUCT DATA

- A. Ground resistance readings specified in paragraph 26 05 26-3.6 shall be provided in accordance with Section 01 33 23.

PART 3 EXECUTION

3.1 GENERAL

- A. Provide grounding system in compliance with the NFPA 70 National Electrical Code (NEC). Do not use grounding conductor as a system neutral.
- B. Make embedded and buried ground connections by compression connectors utilizing diamond or hexagon dies and a hand compression tool for wire sizes 2 AWG and smaller and a hydraulic pump and compression head for wire sizes 2/0 AWG and larger. Alternate method allowed: exothermic welding using a remote igniter device.
- C. Use tools and dies approved for this purpose; dimple compressions are not acceptable. Prepare compression connections in accordance with the manufacturer's instructions. Use compression-type lugs in accordance with manufacturer's recommendations. Make exposed ground connections to equipment by bolted clamps unless otherwise specified. Do not use solder material in any part of the ground circuits.
- D. Securely attach embedded ground conductors and fittings to concrete reinforcing steel with tie wires and prevented from displacement during concrete placement.
- E. Notify the Engineer two hours prior to backfilling, as each part of the grounding system installed below finished grade is complete and ready for inspection. Non-compliance shall affect the payment schedule for this work.
- F. Extend grounding conductors beyond concrete surfaces for equipment connection a sufficient length to reach the final connection point without splicing. Provide grounding fittings, pads, or plates as shown in the electrical details. Minimum grounding conductor extension shall be 3-feet.
- G. Locate grounding conductors which project from a concrete surface as close as possible to a corner of the equipment pad, protected by rigid conduit bonded to the grounding conductors, or terminated in a flush grounding plate.
- H. Support exposed grounding conductors by noncorrosive metallic hardware at 4-foot intervals or less. Terminate grounding conductors for shown and future equipment using an equipment grounding plate.
- I. Bond ground conductors entering electrical enclosures to a single ground bus or terminal strip in the enclosure and to metallic raceways within or terminating at the enclosure. Direct ground connections to enclosure chassis or back plate are not acceptable. Prior to making ground connections or bonds, clean the metal surface at the point of connection.
- J. Directly connect lightning arresters to the ground grid system using lightning industry braided copper conductors, sized as specified.
- K. Terminate metallic sheaths or shields of shielded power cable by a copper ground bus provided with cable connection for connection to the grounding system.

3.2 RACEWAY GROUND

- A. All service, feeder and branch circuit raceways shall contain a green insulated ground conductor sized per applicable NFPA 70 National Electrical Code (NEC) tables:
 - 1. T250.66 - Grounding Electrode Conductor for Alternating-Current Systems or
 - 2. T250.122 - Minimum Size Equipment Grounding Conductors for Grounding Raceways and Equipment.
- B. Bond metallic conduits terminating at concentric knock-outs or reducing washers using insulated grounding bushings. Connect grounding bushings to the grounding system using conductors sized in compliance with NEC.
- C. Cable trays shall have 2/0 or 4/0 bare copper ground conductor run on the outside of each tray or tray group of tiered cable tray. Connect conductor to each section or fitting using an approved ground-clamp and supported at 5 foot intervals.

3.3 EQUIPMENT AND ENCLOSURE BONDING

- A. Bond electrical distribution and utilization equipment enclosure ground bus, motor frames, manholes, metal structures and buildings, outdoor metal enclosures, fences and gates to the grounding system with conductor sizes as specified.
- B. Connect the conductor to the metal enclosure using a UL listed connector, where the enclosure does not contain an internal ground bus
- C. Connect non-electrical equipment with metallic enclosures, that are located outdoor and without a cover or a shade to the grounding system.

3.4 ISOLATED GROUNDING

- A. Install an isolated ground system where required by an equipment manufacturer. The isolated ground conductor shall have green insulation with a yellow stripe and shall be run in the same raceway as the power and neutral conductors. Keep the isolated ground bus isolated from neutral and grounding buses.
- B. Where specifically directed by the Engineer and required by an equipment manufacturer, provide an additional isolated ground conductor from the service or separately derived system to an isolated ground bus bar at each associated distribution point.

3.5 SERVICE AND SEPARATELY DERIVED SYSTEM BONDING

- A. Install a neutral bonding jumper in only one location for each service or separately derived system. Locate the bonding jumper at the service source or the first immediate distribution point downstream from the source. Keep the neutral and ground buses isolated from each other except where the bonding jumper is installed.

3.6 GROUNDING SYSTEM TESTS

- A. Test the facility grounding system and the building grounding system to determine the ground resistance. Follow IEEE Standard 81 using the NETA Fall-of-Potential procedure for the grounding test. Submit a plot of ground resistance readings for each isolated ground rod, ground mat, or ground bus on 8-1/2 x 11 inch size graph paper. Point-to-point resistance measurements are not acceptable.
- B. Drive the current reference rod at least 100 feet from the ground rod or grid under test or as recommended by IEEE Standard 81. Make the measurements at 10-foot intervals beginning 25 feet from the test electrode and ending 75 feet from it, in direct line between the ground rod or center of grid and the current reference electrode.
- C. A grounding system that shows greater than 2 ohm resistance for the flat portion of the plotted data shall be considered inadequately grounded.

- D. Add additional parallel connected ground rods and/or deeper driven rods until the ground resistance measurements meet the 2 ohm requirement.
- E. Use of salts, water, or compounds to attain the specified ground resistance is not acceptable.

END OF SECTION

SECTION 26 05 33.13

CONDUIT

PART 1 GENERAL

1.1 SUMMARY

A. Section Includes

<u>Paragraph</u>	<u>Title</u>
1.2	References
1.3	Administrative Requirements
1.4	Submittals
1.5	Quality Assurance
1.6	Delivery, Storage, and Handling
1.7	Field Conditions
1.8	Warranty
2.1	General
2.2	Rigid Metal Conduit
2.3	PVC-Coated Rigid Galvanized Steel Conduit
2.4	Liquid-Tight Flexible Metal Conduit
2.5	Conduit Bushings and Fittings
2.6	Conduit Boxes
3.1	General
3.2	Installation of Rigid Metal Conduit
3.3	Installation of Liquid-Tight Flexible Metal Conduit
3.4	Installation of Underground Conduit
3.5	Conduit Applications

B. Scope

1. Work covered by this section includes furnishing all labor, equipment, and materials required to install electrical conduit and fittings as specified herein and/or shown on the Drawings.
2. The Contractor's attention is called to the fact that all conduits and conduit fittings are not necessarily shown completely on the Drawings, which are more or less schematic. However, the Contractor shall furnish and install all conduit and conduit fittings indicated or required for the proper connection and operation of all equipment and services requiring such conduit.

1.2 REFERENCES

A. Reference Standards

1. ASTM International (ASTM)
 - a. A123/A123M – Standard Specification for Zinc (Hot-Dipped Galvanized) Coating on Iron and Steel Products

- b. C857 – Standard Practice for Minimum Structural Design loading for Underground Precast Concrete Utility Structures
 - c. D149 – Test Method for Dielectric Breakdown Voltage and Dielectric Strength of Solid Electrical Insulating Materials at Commercial Power Frequencies
2. National Electrical Contractors Association (NECA)
 - a. 101 – Standard for Installing Steel Conduit (Rigid, IMC, EMT)
 - b. 105 – Recommended Practice for Installing Metal Cable Trays
 3. National Electrical Manufacturers Association (NEMA)
 - a. 250 – Enclosures for Electrical Equipment (1,000 Volts Maximum)
 - b. C80.1 – Specification for Rigid Steel Conduit, Zinc Coated
 - c. C80.3 – Specification for Electrical Metallic Tubing, Zinc Coated
 - d. RN 1 – Polyvinyl-Chloride (PVC) Externally Coated Galvanized Rigid Steel Conduit and Intermediate Metal Conduit
 - e. VE 1 – Metallic Cable Tray Systems
 4. National Fire Protection Association (NFPA)
 - a. 1 – Standard for Flexible Metal Conduit
 - b. 5 – Standard for Surface Metal Raceways and Fittings
 - c. 6 – Standard for Electrical Rigid Metal Conduit – Steel
 - d. 50 – Standard for Enclosures for Electrical Equipment
 - e. 360 – Standard for Liquid-Tight Flexible Steel Conduit
 - f. 514B – Standard for Conduit, Tubing, and Cable Fittings
 - g. 797 – Standard for Electrical Metallic Tubing
 - h. 870 – Standard for Wireways, Auxiliary Gutters, and Associated Fittings

1.3 ADMINISTRATIVE REQUIREMENTS

A. Coordination

1. Coordinate with other trades when installation of conduit will impact the location of other work or be enclosed by other work.

1.4 SUBMITTALS

A. Action Submittals/Informational Submittals

1. Product Data

a. Manufacturer's Literature

- 1) Rigid galvanized steel conduit.
- 2) PVC-coated rigid galvanized steel conduit, submittal to include copy of manufacturer's warranty.
- 3) Flexible metal, liquid-tight conduit.
- 4) Conduit fittings.
- 5) Wireways.
- 6) Junction and pull boxes used at or below grade.
- 7) Large junction and pull boxes.

- 8) Terminal junction boxes.
 - b. Precast Manholes and Handholes:
 - 1) Dimensional drawings and descriptive literature.
 - 2) Traffic loading calculations.
 - 3) Accessory information.
 - c. Cable Tray Systems:
 - 1) Dimensional drawings, calculations, and descriptive information.
 - 2) NEMA load/span designation and how it was selected.
 - 3) Support span length and pounds-per-foot actual and future cable loading at locations, with safety factor used.
 - 4) Location and magnitude of maximum simple beam deflection of tray for loading specified.
 - 5) Layout drawings and list of accessories being provided.
 - d. Equipment and machinery proposed for bending metal conduit.
 - e. Seismic anchorage and bracing drawings, calculations, and cut sheets.
2. Certificates
- a. Manufacturer's certification of training for PVC-coated rigid steel conduit installer.

1.5 QUALITY ASSURANCE

A. Authority Having Jurisdiction (AHJ)

1. Provide the work in accordance with NFPA 70. Where required by the AHJ, use material and equipment labeled or listed by a nationally recognized testing laboratory or other organization acceptable to the AHJ in order to provide a basis for approval under NEC.
2. Provide materials and equipment manufactured within the scope of standards published by Underwriters Laboratories Inc., which conforms to those standards and has an applied UL listing mark.

B. Qualifications

1. Installers/Applicators/Erectors
 - a. PVC-Coated, rigid Steel Conduit Installer: Certified by conduit manufacturer as having received minimum 2 hours of training on installation procedures.

1.6 DELIVERY, STORAGE, AND HANDLING

A. Storage and Handling Requirements

1. Store conduit on suitable spaced supports above ground and protected from weather.
2. Do not allow water or debris into conduits during storage and handling.

1.7 WARRANTY

- A. Provide a guarantee against defective equipment and workmanship in accordance with requirements of Section 01 78 33 - Warranties and Bonds

PART 2 PRODUCTS

2.1 GENERAL

- A. Unless otherwise shown or specified, provide all conduits as rigid galvanized steel.
- B. Make conduit terminations at electrical equipment subject to vibration using liquid-tight, flexible metal conduit.
- C. Do not use damaged, dented, flattened, or kinked conduit.

2.2 RIGID METAL CONDUIT

- A. Heavy wall, mild steel, rigid metal conduit conforming to ANSI C80.1 and Federal Specification WW-C-581.
- B. Hot dip galvanized both inside and out.
- C. UL listed and stamped.
- D. Provide two coats of bitumastic compound protective coating for rigid galvanized steel conduit used for underground installation.

2.3 PVC-COATED RIGID GALVANIZED STEEL CONDUIT

- A. Meet requirements of NEMA RN 1.
- B. Material
 - 1. Meet requirements of NEMA C80.1 and UL 6.
 - 2. Exterior Finish: PVC coating, 40 mils nominal thickness, bond to metal shall have tensile strength greater than PVC.
 - 3. Interior Finish: Urethane coating, 2 mils nominal thickness.
- C. Threads: Hot-dipped galvanized and factory coated with urethane.
- D. Bendable without damage to either interior or exterior coating.

2.4 LIQUID-TIGHT FLEXIBLE METAL CONDUIT

- A. Provide an oil-resistant, liquid-tight jacket in combination with flexible metal reinforcing tubing designed for use with waterproof fittings.
- B. Include an integral ground wire.
- C. Only use Underwriter's Laboratories approved fittings.
- D. Manufacturers
 - 1. Electric-Flex Company; American Brass Sealite Type UA.
 - 2. Ideal Industries, Inc.; Flexible Metallic Conduit.
 - 3. Engineer approved equal.

2.5 CONDUIT FITTINGS AND BUSHINGS

- A. Wherever conduits terminate in sheet steel boxes, use double bonding type locknuts and bushings except when terminating in cast hubs. Only use insulated metallic type bushings, equal to O. Z. Electrical Manufacturing Company, Type B; T & B Company, 1200 Series; Appleton Electric Company, Type BU-I; or engineer approved equal.
- B. Where conduits terminate in steel or cast NEMA 4 enclosures with no factory-installed threaded hubs, install a threaded hub equal to Myers Electric Products, Inc., Type ST or

STG; Appleton Electric Company, Type HUB; Crouse-Hinds, Type HUB; or engineer approved equal.

- C. Suitably ground all conduits terminating at motor control centers to the motor control center ground bus using grounded type insulated bushings equal to O. Z. Electrical Manufacturing Company, BLB or IGB; Appleton, Type BIB; Thomas and Betts, 3800 Series; or engineer approved equal.
- D. Conduit expansion fittings shall be O. Z. Electrical Manufacturing Company, Type EX with Bonding Jumper, Type XJ; Appleton, Type SJ with Type XJB4 Bonding Jumpers; Crouse-Hinds, Type XJ with GC100 Bonding Jumper; or engineer approved equal.

2.6 CONDUIT BOXES

- A. Exposed conduit boxes and pulling elbows shall be of die-cast, copper-free aluminum with threaded body and removable neoprene- gasketed cover. Use conduit boxes conforming to Federal Specification W-C-586a. Acceptable manufacturers include Crouse-Hinds "Condulet", Appleton "Unilet Form 85", or engineer approved equal.

PART 3 EXECUTION

3.1 GENERAL

- A. Use a minimum size conduit of 3/4-inch for above ground installation and 1-inch for below ground installation unless noted otherwise. Do not allow more than 40 percent of a conduit's internal area to be occupied by conductors.
- B. During construction temporarily plug, cap, or otherwise protect all installed conduits from the entrance of dust, trash, moisture, etc. Replace any conduits which may become clogged. Do not pull in any conductor until all work that might cause damage to the conduit or conductors has been completed.
- C. Securely fasten conduit connections to sheet metal enclosures with double lock nuts inside and outside and provide grounding bushings.
- D. Secure conduit straps or brackets to concrete, brick, or masonry by means of expansion bolts, toggle bolts, or approved drill anchors. No wood plugs will be permitted.
- E. Install conduits supported from building walls with at least 1/4-inch clearance from the wall using pipe spacers equal to Appleton Electric Company, T & B Company, Steel City, or equal. Clamp back to prevent the accumulation of dirt and moisture behind the conduit.
- F. Unless otherwise shown or specified, install exposed rigid conduit parallel or at right angles to structural members, surfaces, and building walls.
- G. Install two or more conduits in the same general routing parallel with symmetrical bends.
- H. Install conduits at least 12 inches from high temperature piping, ducts, and flues.
- I. Allow headroom of at least 7 feet for conduit installed horizontally, except where it may be installed along structures, piping, equipment, or in other areas where headroom cannot be maintained because of other considerations.
- J. Wherever necessary and where shown on the Drawings, insert conduit boxes and pulling elbows in the lines. Use gaskets to ensure a dust and watertight installation on all conduit boxes and fittings.
- K. Provide a bend radius of not less than 6 times the internal diameter of the conduit for all bends and turns in conduits. Make bends using an approved bender to provide smooth bends with no kinks, dents, or flattening.
- L. Run all conduit exposed wherever practical.

- M. Place all concealed conduit in walls, floors, ceilings, or slabs at the proper time in accordance with the progress of the work. Cooperate in every respect in meeting schedules and do not delay the structural work unnecessarily. Block and brace conduits embedded in concrete in place by use of adequate conduit separators to prevent displacement during pouring of the concrete. Where conduit interferes with structural steel, steel reinforcement, or in the opinion of the Engineer occupies too much space in the slab, rearrange the conduits or install it exposed as directed by the Engineer. No additional payment will be made for such rearrangement of conduit whether or not additional conduit or fittings might be required.
- N. Install conduit wall seals with water stops in outside walls below grade for all incoming or outgoing underground conduit emerging directly into the building area. Provide a pressure ring and sealing grommet on the conduit wall seals to ensure a watertight installation.
- O. Install conduit expansion fittings and ground bonding jumpers on all conduits passing through building expansion joints to provide movement in the conduit system.
- P. Where groups of conduits terminate together or pass through floors, provide template to hold conduits in proper relation to each other and to building.
- Q. Plug or cap conduits with plastic caps during construction to protect threads and prevent entrance of dirt and water.
- R. Adequately support conduits at intervals as required by the National Electrical Code. One to two exposed conduits running parallel to each other may be supported by strap anchors, or 1-hole clamps (walls only). Support exposed conduits larger than 2 inches or groups of more than 2 conduits run parallel by means of minimum 12 gauge, slotted steel channels fitted with 2-piece, bolted pipe clamps. All conduit supports, clamps, straps and brackets shall be heavily hot dip galvanized for corrosion resistance.
- S. Do not allow more than four 90-degree bends (360-degrees total) in runs of conduit between conduit boxes, panel boards, or terminations. In general and to the extent practical do not exceed a conduit length of 100 feet between conduit boxes or similar means of access.
- T. Identify exposed service entrance conduits and main feeder conduits using stenciled letters at intervals not to exceed 20 feet. Use a lettering size equal to one-half the diameter of the conduit or 2 inches, whichever is less.

3.2 INSTALLATION OF RIGID METAL CONDUIT

- A. Use threaded terminations and connections for rigid metal conduit. Ream conduits free of burrs and terminate with insulated metallic conduit bushings.
- B. Coat conduit threads with a petroleum base corrosion-inhibitor with low electrical contact resistance before assembly equal to Burndy Engineering Company, Inc., Penetrax "A" or equal screw thread lubricant (zinc-petroleum or zinc-chromate compounds are permissible).
- C. Suitably ground all conduits to the plant ground grid using grounded type insulated bushings, O. Z. Electrical Manufacturing Company, Type BLG or IGB, T & B Company, Appleton Electric Company, or equal.
- D. Provide bonded, weathertight expansion and deflection fitting the same size as the conduit where conduit is installed across structural joints where structural movement is allowed.
- E. Do not exceed a support spacing of 6 feet for conduits 1 inch and smaller or 10 feet for conduits 1¼ inches and larger. Provide supports as specified under basic electrical materials and methods. Conduits 1½-inch and smaller may be supported by 1-hole conduit straps. Support conduits 2 inches and larger by 2-hole conduit straps. Use conduit racks as

manufactured by Unistrut, Kindorf, or equal. Use PVC coated or type 316 stainless steel conduit racks.

- F. Make conduit joints up tight using a pipe wrench. Do not use channel lock pliers. Provide unions as necessary to aid in the installation. Cut conduits square and ream the ends smooth after threading to prevent injury to conductors. Conduit joints in concrete or exposed to weather or damp locations shall be drawn up tight and coated with insulating paint before casting in concrete or painting exposed conduit system.
- G. Install plastic-coated rigid metal conduit and fittings in accordance with the manufacturer's specifications and recommendations. Repair any damage to the plastic coating in accordance with the manufacturer's requirements.

3.3 INSTALLATION OF LIQUID-TIGHT FLEXIBLE METAL CONDUIT

- A. Make terminations at motors with flexible liquid-tight metal conduit from conduit stub to terminal box; make flexible connection as short as possible. Use Type UA, black flexible conduit. Underwriter's Laboratories approved flexible liquid-tight conduit connectors shall be as manufactured by Thomas and Betts Company, Appleton Electric Company, or equal.
- B. Uncoated flexible metal conduit may be used for short connections between junction boxes and lighting fixtures installed in suspending ceiling systems. Connect flexible metal conduit using Underwriters Laboratories approved grounding connectors.

3.4 INSTALLATION OF UNDERGROUND CONDUIT

- A. Do not conceal or encase conduit until the Engineer has inspected the conduit for proper installation and accurate placement.
- B. The Contractor shall be responsible for all excavating, draining trenches, forming of duct assembly and protective concrete envelope, backfilling, and removal of excess earth.
- C. Install underground conduit with a minimum 3-inch per 100-foot downward slope for drainage. Provide drains at all low points.
- D. Make bends and turns using long sweeps. Only use ninety-degree bends where required and keep usage at a minimum.
- E. Install all underground conduit runs for voltages less than 600 volts at least 24 inches below grade with a minimum conduit separation of 4 inches.
- F. Rod and pull a mandrel through all underground conduit runs followed by a swab to clean out any obstructions which may cause cable abrasions. Use a mandrel 12 inches in length with a diameter $\frac{1}{2}$ inch less than the inside diameter of the conduit.
- G. Mark all underground conduit runs with a strip of permanently-colored red polyethylene tape, 0.004 inch thick and 6 inches wide, buried above the conduit and 6 inches below finished grade.
- H. Where concrete encased duct banks are installed, mix the concrete with a red dye or paint the top of the concrete red after it has cured and prior to backfilling.
- I. Unless otherwise shown, provide spare conduits, with water-proof plugs at stub-ups and furnish with a No. 8 aluminum pulling wire.

3.5 CONDUIT APPLICATION

- A. Install the following conduit types, unless otherwise shown on the drawings.
 - 1. Outdoors, Exposed (Not Buried): PVC-coated galvanized rigid steel
 - 2. Indoor, Exposed: Rigid galvanized steel.

3. Underground: Schedule 40 PVC encased in concrete ductbank.
4. Transition Areas and Final Connections to Equipment: Flexible metal, liquid-tight conduit.

END OF SECTION

SECTION 40 90 01

GENERAL REQUIREMENTS FOR INSTRUMENTATION AND CONTROL

PART 1 GENERAL

1.1 SUMMARY

A. Section Includes

<u>Paragraph</u>	<u>Title</u>
1.2	References
1.3	Administrative Requirements
1.4	Submittals
1.5	Quality Assurance
1.6	Field Conditions
1.7	Warranty
2.1	General
2.2	Nameplates
3.1	Installation
3.2	Field Tests and Inspections
3.3	Attachments

B. Scope

1. This section specifies general requirements which are applicable to providing a complete, functional process control, instrumentation, communication, and signal systems for the Gwinnett County Pump Station Project. The requirements of this section are applicable to all work specified in Division 40 of these specifications.
2. Electrical requirements applicable to this work include those specified in Section 26 00 01 for general electrical requirements; Section 26 00 02 for electrical devices; and Section 26 09 01 for control panels.

C. Description of Work

1. Instrumentation and Control System:
 - a. Small Pump Station:
 - 1) Supply a single pump station control panel (PSCP) which houses the pump starters/VFDs and protection equipment, as well as, the pump station control and remote telemetry equipment. Design and manufacture the cabinet per the requirements of Section 40 95 16 and the example drawings.
 - 2) Perform all work and provide materials which comply with the National Electrical code and applicable local regulations and ordinances. Where required by applicable codes, cabinet assemblies, materials and equipment shall be approved, identified, labeled or listed by Underwriters' Laboratories.
 - 3) Design the cabinet to absorb vibrations or mechanical movement from the motor starts or other active equipment. These movements shall not cause undue vibrations in the control panel. As a minimum, include additional

stiffeners or other vibration dampening equipment for any size 3 or greater starters.

2. Programming: Programming shall be provided by Owner.

D. Functional Requirements

1. The instrumentation and control system functions are shown on the drawings and specified in subsequent sections of Division 40. The Systems Integrator drawings and integration practices shall be as defined in IEEE 100, ISA S51.1, and NEMA ICS 1.

1.2 REFERENCES

A. Definitions

1. General: Definitions of terminology related to Instrumentation and Industrial Electronic Systems used in the specifications shall be as defined in IEEE 100, ISA S51.1, and NEMA ICS 1.
2. Two-Wire Transmitter: A transducer which derives operating power supply from the signal transmission circuit and requires no separate power supply connections. A two-wire transmitter produces a 4 to 20 milliampere current regulated signal in a series circuit with a 24 volt direct current driving potential and a maximum circuit resistance of 600 ohms.
3. Four-Wire Transmitter: A transducer which derives operating power from separate power supply connections. A four-wire transmitter produces a 4 to 20 milliampere current regulated signal in a series circuit with a maximum circuit resistance of 600 ohms. Four-wire transmitters typically require 120Vac or 24Vdc input power supply.
4. Galvanic Isolation: Electrical node having no direct current path to another electrical node. Galvanic isolation refers to a device with electrical inputs and/or outputs which are isolated from ground, the device case, the process fluid, and separate power supply terminals. Inputs and/or outputs may be externally grounded without affecting the characteristics of the devices or providing path for circulation of ground currents.
5. Panel: An instrument support system which may be a flat surface, a partial enclosure, or a complete enclosure for instruments and other devices used in process control systems including consoles, cabinets and racks. Panels provide mechanical protection, electrical isolation, and protection from dust, dirt, moisture, and chemical contaminants which may be present in the atmosphere.
6. Data Sheets: Data sheets shall refer to ISA S20 or ISA TR20.00.01.
7. Signal Types: Used in systems specified in Division 40:
 - a. Low-Level Analog: Signal with full output level of 100 millivolts or less including thermocouples and resistance temperature detectors.
 - b. High-Level Analog: Signals with full output level greater than 100 millivolts but less than 30 volts, including 4-20 mA transmission.
 - c. Digital Code: Coded information from the output of an analog to digital converter or digital transmission terminal.
 - d. Pulse Frequency: Counting pulses emitted from speed or flow transmitters.
 - e. Modulated Signals: Signals from modems or low level audio signals. Normal signal level: plus 4 dBm to minus 22 dBm. Frequency range is 300 to 10,000 Hertz.
 - f. Discrete Control or Events: Dry contact closures and signals monitored by solid state equipment, relays, or control circuits.

- g. Low Voltage Discrete Control or Events: Dry contact closures and signals monitored by solid state equipment, relays, or control circuits operating at less than 30 volts and 250 milliamperes.
 - h. High-Level Audio Signals: Audio signals exceeding plus 4 dBm, including loudspeaker circuits.
 - i. Radio Frequency Signals: Continuous wave alternating current signals with fundamental frequency greater than 10 kilohertz.
8. Systems Integrator: A firm engaged in the business of detailed control system design and engineering, instrumentation component purchase, system and panel assembly, programming, and implementing the specified process control and industrial automation systems.

B. Reference Standards

- 1. This section contains references to the following documents. They are a part of this section as specified and modified. Where a referenced document contains references to other standards, those documents are included as references under this section as if referenced directly. In the event of conflict between the requirements of this section and those of the listed documents, the requirements of this section shall prevail.
- 2. Unless otherwise specified, references to documents shall mean the documents in effect at the time of Advertisement for Bids or Invitation to Bid (or on the effective date of the Agreement if there were no Bids).
- 3. If referenced documents have been discontinued by the issuing organization, references to those documents shall mean the replacement documents issued or otherwise identified by that organization or, if there are no replacement documents, the last version of the document before it was discontinued.
- 4. Where document dates are given in the following listing, references to those documents shall mean the specific document version associated with that date, regardless of whether the document has been superseded by a version with a later date, discontinued or replaced.

Reference	Title
IEEE 100	Standard Dictionary of Electrical and Electronics Terms
ISA S5.4	Instrument Loop Diagrams
ISA S20	Specification Forms For Process Measurement and Control Instrumentation, Primary Elements, and Control Valves
ISA S51.1	Process Instrumentation Terminology
ISA TR20.00.01	Specification Forms for Process Measurement and Control Instruments Part 1: General Considerations
NEMA ICS 1	General Standards for Industrial Control and Systems

1.3 ADMINISTRATIVE REQUIREMENTS

A. Pre-Submittal Conference

- 1. Schedule a pre-submittal conference with the Owner and Engineer within 30-calendar days after Contract award to discuss the work, equipment, submittal format, and establish the framework for project coordination and communication.
- 2. Provide materials 10-days prior to the conference:

- a. Instrument Index that lists the devices and instruments specified in Division 40. Identify each by tag number, description, function, manufacturer, and model number.
 - b. Product descriptive literature with a statement that the item is as specified.
 - c. Proposed equal products with comparative listing of the published specifications for the specified item and the proposed item.
 - d. Project schedule with deliverables and milestones.
 - e. Project Control System Block Diagram, when specified.
 - f. Sample portion of documented PLC and Operator Interface program, when specified.
 - g. Sample Spec. 40 95 16 control panel schematic diagram proposed for this project, when specified. Sample can be a copy from a previous project provided that it represents the format being proposed for this project.
 - h. Sample analog and discrete loop diagrams proposed for this project, when specified. Sample can be a copy from a previous project provided that it represents the format being proposed for this project.
 - i. A copy of this specification section, with addendum updates included, and all referenced and applicable sections, with addendum updates included, with each paragraph check-marked to indicate specification compliance or marked to indicate requested deviations from specification requirements. A check mark shall denote full compliance with a paragraph as a whole. If deviations from the specifications are indicated, and therefore requested by the Supplier, each requested deviation shall be underlined and denoted by a number in the margin to the right of the identified paragraph, referenced to a detailed written explanation of the reasons for requesting the deviation. The Engineer shall be the final authority for determining acceptability of requested deviations. The remaining portions of the paragraph not underlined will signify compliance on the part of the Supplier with the specifications.
3. The pre-submittal conference will not replace the Product and Shop Drawing Submittal review process.

B. Process Equipment Coordination

1. Coordinate Division 40 specified equipment for proper operation with equipment related process equipment specified in other Divisions.
2. Integrate, furnish, and install equipment in conformance with the drawings, specifications, and the recommendations of the equipment manufacturer and the related processes equipment manufacturers.
3. Systems Integrator shall obtain manufacturer's technical information for items of equipment not provided with, but directly connected to, the control system. Provide the necessary coordination and components for correct signal interfaces between specified equipment and the control system.
4. Systems Integrator shall coordinate with project subcontractors and equipment suppliers.
5. Systems Integrator shall provide on-site installation supervision for the duration of the project.
6. Present conflicts between the plans, specifications, manufacturer/vendor drawings and installation instructions, etc., to the Engineer for resolution before proceeding.

1.4 SUBMITTALS

A. Action Submittals/Informational Submittals

1. Product Data

- a. Detailed product literature, showing product specifications and model number breakdown. Mark to denote features and options included. Include only the applicable pages.
- b. Nameplate list with material, tag number and description as specified herein.
- c. Data Sheets in accordance with ISA 20 for each instrument. Identical instruments may be submitted with one common ISA Data Sheet and accompanying tag list.

2. Shop Drawings

a. General:

- 1) The drawings included in the project manual are functional in nature and do not show exact locations of equipment or interconnections between equipment. The Supplier's Systems Integrator shall prepare detailed installation drawings as specified below.
- 2) Drawings prepared in an AutoCAD version current with file format 2013 with borders and title blocks identifying the project, system, revisions to the drawing, and type of drawing. Each revision of a drawing shall include the date and description of the revisions. Drawing prints shall be 11" x 17" with a minimum lettering size of 1/8".
- 3) Diagrams shall carry a uniform and coordinated set of wire numbers and terminal block numbers in compliance with panel wiring, Section 26 00 01 and Section 40 95 16, to permit cross-referencing between contract documents and the drawings prepared by the Supplier.

b. Connection Diagrams: Show components of a control panel in an arrangement similar to the actual layout of the panel including internal wiring between devices within the panel. Show terminal blocks used for internal wiring or field wiring, identified as such. Indicate insulation color code, signal polarities, and wire numbers and terminal block numbers.

c. Interconnection Diagrams: Show panels, panel devices, and field devices with wire numbers, cable numbers, raceway numbers, terminal box numbers, terminal block numbers, panel numbers, and field device tag numbers.

d. Elementary or Schematic Diagram: Shows, by means of graphic symbols, the electrical connections and functions of a specific circuit arrangement. Provide schematics for internal panel power distribution, lighting, and any panel HVAC.

e. Arrangement, Layout, or Outline Drawings: Show the dimensioned external and interior control panel views with components and Bill of Material. Provide panel heat load calculations, and indicate cooling or ventilation provisions as required.

f. Network Block Diagram: A network block diagram is a diagram of the overall SCADA system, with annotated boxes to show the primary network components (controllers, hubs, switches, computers, displays), and annotated interconnecting lines that show the system communication media and communication protocols.

3. Manufacturer's Instructions

a. Manufacturer's installation manual excerpts, as to be used for this project:

- 1) Installation details/drawings.
- 2) Electrical connection diagrams

3) Calibration procedures.

4. Special Procedure Submittals

- a. A copy of this specification section, with addendum updates included, and all referenced and applicable sections, with addendum updates included, with each paragraph check-marked to indicate specification compliance or marked to indicate requested deviations from specification requirements. A check mark shall denote full compliance with a paragraph as a whole. If deviations from the specifications are indicated, and therefore requested by the Supplier, each requested deviation shall be underlined and denoted by a number in the margin to the right of the identified paragraph, referenced to a detailed written explanation of the reasons for requesting the deviation. The Engineer shall be the final authority for determining acceptability of requested deviations. The remaining portions of the paragraph not underlined will signify compliance on the part of the Supplier with the specifications.
- b. Failure to include a copy of the marked-up specification sections, along with justification for requested deviations from the specification requirements, with the submittal shall be sufficient cause for rejection of the entire submittal with no further consideration.

B. Closeout Submittals

1. Operation and Maintenance Data

- a. Provide operating and maintenance information in accordance with Section 01 78 23. Include the following in each Operation and Maintenance manual:
 - 1) Final reviewed Submittals, including revised as-built record drawings.
 - 2) Manufacturer's operation and maintenance instructions, edited for this project.
 - 3) Written record of menu configuration, jumpers, switch settings, and other configurable parameters for each instrument.

2. Record Documentation

- a. Provide record drawings specified by paragraph 1.4.A.2 and the schedules included in Division 40 in accordance with the latest AutoCAD format and PDF format on CD.
- b. Provide record drawing prints of all drawings following project start-up, but prior to acceptance of the work showing the final constructed state of the instrumentation and control systems.

1.5 QUALITY ASSURANCE

A. System Integrator Responsibility

1. The specified control system and instrumentation integration including panel building, instrument calibration, testing, start-up, operational testing, and training shall be performed by a Systems Integrator staffed with qualified personnel, possessing necessary equipment and experience in performing similar installations.
2. The control system components shall, as far as practical, be of one manufacturer.
3. The components, modules, devices, and control system equipment shall be recognized industrial quality products. Recognized commercial or office grade products are prohibited.
4. The overall system performance shall be demonstrated to and accepted by Owner.

5. The application software packages shall be latest versions available, or compatible with existing software currently in use, as specified in Section 40 68 16.
- B. System Integrator Qualifications
1. The following Systems Integrators are pre-qualified to perform the work specified in Division 40 without the need to provide Evidence of Experience:
 - a. M/R Systems, Norcross, GA
 - b. C2I, Smyrna, GA
 - c. Global Control Systems, Smyrna, GA
 - d. Revere Control Systems, Birmingham, AL
 - e. Turbitrol, Austell, GA
 - f. Sta-con, Apopka, FL
 - g. Smith and Loveless, Lenexa, KS
 - h. Transdyn, Duluth, GA
 2. Supplier-proposed Systems Integrator shall be evaluated based on submittal of the following Evidence of Experience:
 - a. Submit evidence of experience in performing three similar successful projects in the last five years with one project currently in progress or completed within the last two years.
 - b. Submit project descriptions with contact names, addresses, and telephone numbers from the project Owner, General Contractor, and Principal Design Firm.
 - c. Submit organization chart and resumes for proposed project personnel.
 - d. Submit Training and Certification information. Completion of the following training courses or appropriate portions thereof or possession of the following certifications included with the Systems Integrator's personnel experience requirements described above:
 - 1) Project manager: Control System Engineer (CSE) registration, Professional Engineer (PE) registration.
 - 2) Systems engineer: Control System Engineer (CSE) registration, Professional Engineer (PE) registration, or completion of the relevant core courses in the Engineering Skills Training program.
 - 3) Programmer: Control System Engineer (CSE) registration, Professional Engineer (PE) registration.
 - 4) Field instrument technician: Certified Control Systems Technician (CCST) registration or completion of the relevant core courses in the Technical Skills Training program.
 - 5) Certified training programs, as offered by ISA.
 - e. Submit financial data for Systems Integrator division when subsidiary to a parent corporation. Include two years of financial data.
 - 1) Financial Statement.
 - 2) Balance Sheet.
 - 3) Dun & Bradstreet Report.

1.6 FIELD CONDITIONS

- A. Provide specified data communication and process control equipment suitable for operation in indoor locations and in outdoor locations.
- B. Ambient Conditions
 - 1. Temperature Range: -20°F to 120°F.
 - 2. Relative Humidity: 0 to 100%.
 - 3. Potential for direct sunlight.
- C. Corrosive Locations
 - 1. Corrosive locations shall be as specified in Division 26.
- D. Hazardous (Classified) Areas
 - 1. Hazardous areas shall be as specified in Division 26.

1.7 WARRANTY

- A. Manufacturer Warranty
 - 1. Provide a warranty against defective or deficient materials and workmanship in accordance with the requirements of Section 01 78 33.

PART 2 PRODUCTS

2.1 GENERAL

- A. Materials and Quality
 - 1. Provide equipment material that is new, free from defects, and industrial-grade, as specified. Where possible, use one manufacturer for each type of instrument, instrument accessory, and device used throughout the work.
 - 2. Provide electronic equipment of solid-state construction with printed or etched circuit boards of glass epoxy of sufficient thickness to prevent warping.
- B. Enclosures
 - 1. Table A specifies the instrument and control panel enclosure material and minimum NEMA rating for the location and application.

Location	Enclosure Material and NEMA Rating
Indoor: Architecturally Finished Area	NEMA 12: mild steel
Indoor: Electrical Room	NEMA 12: mild steel
Indoor: Process Areas	NEMA 4X: 316 Stainless Steel
Indoor: Corrosive Area	NEMA 4X: 316 Stainless Steel
Outdoor: Corrosive Area	NEMA 4X: 316 Stainless Steel
Outdoor: Non-Corrosive Areas	NEMA 4X: 316 Stainless Steel
Corrosive Area (Hypochlorite)	NEMA 4X: Non-metallic
Hazardous Area:	NEMA 7: Galvanized Malleable Iron or Aluminum or NEMA 4X and UL listed or FM Approved for the Hazardous Area
Hazardous and Corrosive Area	NEMA 7: Iron or Aluminum with factory applied corrosion resistant coating or NEMA 4X and UL listed or FM Approved for the

2.2 NAMEPLATES

- A. Provide nameplates for all field mounted instrument, analyzer, or equipment specified in Division 40. Include the equipment or instrument loop title and the instrument or equipment tag number on the nameplate, where nameplate engraving is not specified or shown. Provide machine engraved black phenolic nameplates with white 5/32-inch high lettering, as minimum, unless otherwise specified or shown. Nameplate wording may be changed without additional cost or time, if changes are made prior to commencement of engraving.
- B. Attach nameplates to support hardware with a minimum of two self-tapping type 316 stainless steel screws in a readily visible location so the nameplate will remain to identify the service when the device is removed. Attach field instrument nameplates with braided stainless steel straps where not stand mounted.

PART 3 EXECUTION

3.1 INSTALLATION

A. General

- 1. Install equipment in locations that are accessible for operation and maintenance services. Equipment not accessible shall be reinstalled at no cost to the Owner.
- 2. Installation, calibration, settings, and testing procedures are specified in Section 40 90 01, Section 40 96 20 – Instrument Index, Part 3 Execution, and subsequent sections of Division 40.

B. Field Equipment

- 1. Provide equipment with ports and adjustable items accessible for in-place testing and calibration. Install equipment between 48 inches and 60 inches above the floor or permanent work platform. Mount equipment to avoid shock or vibration that may impair operation. Mount equipment for unobstructed access and walkways. Do not attach equipment support systems to handrails, process piping or mechanical equipment.
- 2. Space instruments and cabinets supported by concrete walls 5/8-inch from the wall by using framing channel between instrument or cabinet and wall. For block walls, provide additional supports, as required, to avoid damage to the wall. Use equipment supports that are hot-dip galvanized after fabrication or 316L stainless steel, as shown or specified.
- 3. Design support systems including panels to prevent deformation greater than 1/8-inch in any direction under the attached equipment load and under an external load of 200 pounds.
- 4. In wet or outdoor areas, make conduit penetrations into instrument housing through the bottom (preferred) or side of enclosures to minimize water entry from around or from inside of conduits. Provide conduit hubs for connections and waterproof mastic for moisture sealant.
- 5. Provide nameplates for all field mounted equipment. Attach nameplates to support hardware with a minimum of two self-tapping Type 316 stainless steel screws in a readily visible location, but such that if the field device is changed out, the nameplate will remain to identify the service.

C. Electrical Power Connections

1. Provide equipment electric power wiring that complies with Division 26. Provide power disconnect switches within sight of equipment and labeled to indicate the specific equipment served and the power source location. "Within sight of" is defined as having an unobstructed view from the equipment served and within 50 feet of the equipment served.
2. Mount equipment power disconnect switches between 36 inches and 72 inches above the floor or permanent work platform. Where equipment location requirements cannot be met by a single disconnect switch, provide two disconnect switches: one at the equipment and one at the work platform.
3. Provide a surge arrestor on each 120 volt AC disconnect switch serving equipment located outdoors. Surge arrestor shall be Telematic, LP Series or equal.

D. Signal Connections

1. Make equipment electric signal connections on terminal blocks or by locking plug and receptacle assemblies. Use flexible cable, receptacle and plug assemblies where shown or specified.
2. Use jacketed flexible conduit between equipment and rigid raceway systems. Flexible cable assemblies may be used where plug and receptacle assemblies are provided and the installation is not subject to mechanical damage in normal use. The length of flexible conduit or cord assemblies shall not exceed 2 feet except where sufficient length is required to allow withdrawal of instruments for maintenance or calibration without disconnection of conduit or cord assemblies.

3.2 FIELD TESTS AND INSPECTIONS

A. Delivery Inspection

1. Notify the Owner's Representative upon arrival of any material or equipment to be incorporated into the work. Remove protective covers or otherwise provide access in order that the Owner's Representative may inspect such items.

3.3 ATTACHMENTS

A. Attachments listed below, following "END OF SECTION," are a part of this Specification:

Form No.	Title
40 90 01-A	Loop Wiring and Insulation Resistance Test Data Form
40 90 01-B	Control Circuit Piping Leak Test Form
40 90 01-C	Controller Calibration Test Data Form
40 90 01-D	Panel Indicator Calibration Test Data Form
40 90 01-E	Recorder Calibration Test Data Form
40 90 01-F	Signal Trip Calibration Test Data Form
40 90 01-G	Field Switch Calibration Test Data Form
40 90 01-H	Transmitter Calibration Test Data Form
40 90 01-I	Miscellaneous Instrument Calibration Test Data Form
40 90 01-J	Individual Loop Test Data Form
40 90 01-K	Loop Commissioning Test Data Form

END OF SECTION

40 90 01-A. LOOP WIRING AND INSULATION RESISTANCE TEST DATA FORM

Loop No.: _____

List all wiring associated with a loop in table below. Make applicable measurements as indicated after disconnecting wiring.

Wire No.	Panel Tie	Field TB	Continuity Resistance ^a		Insulation Resistance ^b			
			Cond./ Cond.	Cond./ Shield	Shield/ Gnd.	Shield/ Cond.	Cond./ Gnd.	Shield/ Shield
A			--	(A/SH)				
B			(A/B)	--				
C			(A/C)	--				
D			(A/D)	--				
etc.								

NOTES:

- a. Continuity Test. Connect ohmmeter leads between wires A and B and jumper opposite ends together. Record resistance in table. Repeat procedure between A and C, A and D, etc. Any deviation of ± 2 ohms between any reading and the average of a particular run indicates a poor conductor, and corrective action shall be taken before continuing with the loop test.
- b. Insulation Test. Connect one end of a 500 volt megger to the panel ground bus and the other sequentially to each completely disconnected wire and shield. Test the insulation resistance and record each reading.

CERTIFIED _____ Date _____
Supplier's Representative

WITNESSED _____ Date _____
Owner's Representative

40 90 01-B. CONTROL CIRCUIT PIPING LEAK TEST FORM

Loop No.: _____

List tubing associated with loop in table below. Make applicable measurements after isolating any air consuming pilots from circuit.

Tube No.	Tubing Equivalent Length of 1/4-Inch Copper ^a	Test Period (seconds)	Permitted Pressure Drop (psi) ^b	Measured Pressure Drop (psi)
A				
B				
C				
D				
etc.				

NOTES:

- a. Convert actual tubing and air motor volume to equivalent 1/4-inch copper tubing.
- b. Pressure drop shall not exceed 1 psi per hundred feet 1/4-inch tubing per 5 seconds.

CERTIFIED _____ Date _____
 Supplier's Representative

WITNESSED _____ Date _____
 Owner's Representative

40 90 01-C. CONTROLLER CALIBRATION TEST DATA FORM

Tag No. and Description: _____

Make & Model No.: _____ Serial No.: _____

Input: _____ Process Variable (PV) Scale: _____

Output: _____ Output Scale: _____

PV Scale Calibration

% of Range	Input	Expected Reading	Actual Reading	% Deviation
0				
50				
100				
% Deviation Allowed:				

Connect output to PV for following tests:

Set Point (SP) Indicator Accuracy			Output Meter Accuracy			Controller Accuracy		
SP	PV Reading	Expected % Dev.	Actual Reading	Expected Reading	Actual % Dev.	Output	Output	% Dev.
(0%)								
(50%)								
(100%)								
% Deviation Allowed:			% Deviation Allowed:			% Deviation Allowed:		

CERTIFIED _____ Date _____
 Supplier's Representative

WITNESSED _____ Date _____
 Owner's Representative

40 90 01-D. PANEL INDICATOR CALIBRATION TEST DATA FORM

Tag No. and Description: _____

Make & Model No.: _____ Serial No.: _____

Input: _____

Scale: _____ Range: _____

PV Scale Calibration

% of Range	Input	Expected Reading	Actual Reading	% Deviation
0				
50				
100				
% Deviation Allowed:				

CERTIFIED _____ Date _____
 Supplier's Representative

WITNESSED _____ Date _____
 Owner's Representative

40 90 01-E. RECORDER CALIBRATION TEST DATA FORM

Tag No. and Description: _____

Make & Model No.: _____ Serial No.: _____

Input: _____ Chart: _____

Scale: _____ Range: _____

% of Range	Input	Expected Reading	Actual Reading	% Deviation
0				
50				
100				
% Deviation Allowed:				

CERTIFIED _____ Date _____
 Supplier's Representative

WITNESSED _____ Date _____
 Owner's Representative

40 90 01-F. SIGNAL TRIP CALIBRATION TEST DATA FORM

Tag No. and Description: _____

Make & Model No.: _____ Serial No.: _____

Input: _____

Scale: _____ Range: _____

Set Point(s): _____

After setting set point(s), run signal input through entire range and calculate deadband.

Set Point	Incr. Input Trip Point	Decr. Input Trip Point	Calc. Deadband	Required Deadband

CERTIFIED _____ Date _____
 Supplier's Representative

WITNESSED _____ Date _____
 Owner's Representative

40 90 01-G. FIELD SWITCH CALIBRATION TEST DATA FORM

Tag No. and Description: _____

Make & Model No.: _____ Serial No: _____

Input: _____

Range: _____

Set Point(s): _____

Simulate process variable (flow, pressure, temperature, etc.) and set desired set point(s). Run through entire range of switch and calculate deadband.

Set Point	Incr. Input Trip Point	Decr. Input Trip Point	Calc. Deadband	Required Deadband

CERTIFIED _____ Date _____
 Supplier's Representative

WITNESSED _____ Date _____
 Owner's Representative

40 90 01-H. TRANSMITTER CALIBRATION TEST DATA FORM

Tag No. and Description: _____

Make & Model No.: _____ Serial No.: _____

Input: _____

Output: _____

Range: _____ Scale: _____

Simulate process variable (flow, pressure, temperature, etc.) and measure output with appropriate meter.

% of Range	Input	Expected Reading	Actual Reading	% Deviation
0				
50				
100				
% Deviation Allowed:				

CERTIFIED _____ Date _____
 Supplier's Representative

WITNESSED _____ Date _____
 Owner's Representative

40 90 01-I. MISCELLANEOUS INSTRUMENT CALIBRATION TEST DATA FORM

(For instruments not covered by any of the preceding test forms, the Supplier shall create a form containing all necessary information and calibration procedures.)

CERTIFIED _____ Date _____
Supplier's Representative

WITNESSED _____ Date _____
Owner's Representative

40 90 01-J. INDIVIDUAL LOOP TEST DATA FORM

Loop No.: _____

Description: (Give complete description of loop's function using tag numbers where appropriate.)

P&ID No.: (Attach copy of P&ID)

- a. Wiring tested:
(Attach test form 40 90 01-A)
- b. Instrumentation tubing/piping tested:
(Attach test form 40 90 01-B)
- c. Instruments calibrated:
(Attach test forms 40 90 01-C through I)
- d. List step-by-step procedures for testing loop parameters. Test loop with instruments, including transmitters and control valves, connected and functioning. If it is not possible to produce a real process variable, then a simulated signal may be used with the Construction Manager's approval.

CERTIFIED _____ Date _____
Supplier's Representative

WITNESSED _____ Date _____
Owner's Representative

40 90 01-K. LOOP COMMISSIONING TEST DATA FORM

Loop No.: _____

- a. Loop tested:
(Attach test form 40 90 01-J)
- b. Controlled or connected equipment tests confirmed:
- c. Give complete description of loop's interface with process.
- d. With associated equipment and process in operation, provide annotated chart trace of loop response to changes in set points for verification of performance. This chart should demonstrate $\frac{1}{4}$ -amplitude damping as output adjusts to set point change. Show set points, starting and finishing times on chart, as well as any other pertinent data.

Connect 2-pen recorder to process variable (PV) and to controller output. Use 1-inch/second chart speed.

Pen 1 - PV - Connections:

Pen 2 - Output - Connections:

CERTIFIED _____ Date _____
Supplier's Representative

WITNESSED _____ Date _____
Owner's Representative

SECTION 40 94 43

PROGRAMMABLE LOGIC CONTROLLER

PART 1 GENERAL

1.1 SUMMARY

A. Section Includes

<u>Paragraph</u>	<u>Title</u>
1.2	References
1.3	Submittals
1.4	Quality Assurance
1.5	Warranty
2.1	General
2.2	PLC Schedule
2.3	Programming Software
2.4	Control Panel Fabrication
2.5	Ethernet Switch
2.6	Panel Mounted Operator Interface
3.1	Installation
3.2	Field Inspection and Testing
3.3	Training
3.4	PLC Input/Output Summary
3.5	Attachments

B. Scope

1. This Section specifies requirements for small and large programmable logic controllers (PLC) designed to execute discrete and continuous control logic with high reliability in industrial applications and operator interface terminal (OIT). Enclosures and components are specified in Section 40 95 16 – Instrument and Control Panels.
2. All PLCs provided for this project shall comply with the requirements of this Section. PLCs provided with equipment specified in Divisions 26, and 43 are provided by the Equipment Manufacturer. Other PLCs are provided by the Systems Integrator per Section 40 90 01.
3. General requirements shall be as specified in Sections 40 90 01 and 40 95 16. PLC assemblies provided by Equipment Manufacturers may be provided by firms other than the Systems Integrator.

1.2 REFERENCES

A. Reference Standards

1. This Section contains references to the following documents or documents listed in Sections 26 00 01, 40 90 01, and 40 95 16. They are a part of this Section as specified and modified. Where a referenced document contains references to other standards, those documents are included as references under this Section as if referenced directly.

In the event of conflict between the requirements of this Section and those of the listed documents, the requirements of this Section shall prevail.

2. Unless otherwise specified, references to documents shall mean the documents in effect at the time of Advertisement for Bids or Invitation to Bid (or on the effective date of the Agreement if there were no Bids).
3. If referenced documents have been discontinued by the issuing organization, references to those documents shall mean the replacement documents issued or otherwise identified by that organization or, if there are no replacement documents, the last version of the document before it was discontinued.
4. Where document dates are given in the following listing, references to those documents shall mean the specific document version associated with that date, regardless of whether the document has been superseded by a version with a later date, discontinued or replaced.

Reference	Title
IEC 61131-3	Programmable Controllers – Part 3: Programming Languages
NEMA IA 2.2	Programmable Controllers – Equipment Requirements and Tests
NEMA IA 2.3	Programmable Controllers – Programming Languages

1.3 SUBMITTALS

A. Action Submittals/Informational Submittals

1. Shop Drawings
 - a. PLC Input/Output (I/O) loop diagram drawings.
 - b. Internal power distribution schematic diagram drawings.
2. Calculations
 - a. PLC power supply loading calculations.
3. Test and Evaluation Reports
 - a. Submit factory acceptance test schedule and forms per the requirements of this Section.
4. Special Procedure Submittals
 - a. A copy of this Specification Section, with addendum updates included, and all referenced and applicable Sections, with addendum updates included, with each paragraph check-marked to indicate Specification compliance or marked to indicate requested deviations from Specification requirements. A check mark shall denote full compliance with a paragraph as a whole.
 - b. If deviations from the Specifications are indicated, and therefore requested by the Supplier, each deviation shall be underlined and denoted by a number in the margin to the right of the identified paragraph, referenced to a detailed written explanation of the reasons for requesting the deviation.
 - c. The Engineer shall be the final authority for determining acceptability of requested deviations. The remaining portions of the paragraph not underlined will signify compliance on the part of the Supplier with the Specifications.
 - d. Failure to include a copy of the marked-up Specification Sections, along with justification(s) for any requested deviations to the Specification requirements, with the submittal shall be sufficient cause for rejection of the entire submittal with no further consideration.

B. Closeout Submittals

1. Operation and Maintenance Data

- a. Manufacturer, Representative, and Supplier contact information.
- b. Manufacturer instruction manuals shall include only the following as applicable to the PLC system:
 - 1) Safety Precautions.
 - 2) Environmental Conditions.
 - 3) Troubleshooting guides and diagnostic techniques.
 - 4) Component connection diagrams.
 - 5) Removal and replacement instructions.
- c. Final reviewed submittal.

2. Warranty Documentation

- a. Submit in accordance with Section 01 78 33.

3. Record Documentation

- a. As-built drawings with record of switch and jumper settings for all components.
- b. Provide the as-built programmable controller program on a CD, prepared using the software type specified in Part 2. Provide 2 copies. Label the CD to include:
 - 1) Owner's name, facility name, project name and project number as shown on the drawings.
 - 2) "Application Programs For (equipment and/or PLC name)".
 - 3) Programming software name and revision.
 - 4) Supplier name and program revision date.
- c. Provide the as-built programmable controller program prepared using the software type specified in Part 2 and per Section 40 90 02.

C. Maintenance Material Submittals

1. Spare Parts

- a. List of spare parts to be provided.

1.4 QUALITY ASSURANCE

A. Qualifications

1. System Integrator

- a. Responsibilities and qualifications shall be as specified in Section 40 90 01.

B. Preconstruction Testing

1. Submit factory test forms for approval prior to tests.
2. Provide all expenses for one Owner staff member and one Engineer staff member to witness factory testing. Travel shall be during business hours on weekdays.

1.5 WARRANTY

A. Manufacturer Warranty

1. Provide a warranty against defective or deficient materials and workmanship in accordance with the requirements of Section 01 78 33.

PART 2 PRODUCTS

2.1 GENERAL

A. Manufacturer

1. The Owner and Engineer require the specified Manufacturer to provide the equipment and/or products to be furnished under this Section. The Owner and Engineer believe the Manufacturer is capable of producing equipment and/or products that will satisfy the requirements of this Section. This statement, however, shall not be construed to mean that the named Manufacturer's standard product will comply with the requirements of this Section.

B. Materials

1. Equipment and/or products shall be new and unused at the time of system assembly.

C. Controller conforming to NEMA IA 2.2 and with required memory and functional capacity to perform specified sequence of operation with scheduled input and output points.

1. RFI/EMI Susceptibility: MIL STD 461B CS02.
2. Showering Arc Test: NEMA Pub No ICS2-230.42.
3. Surge Withstand: ANSI C37.90a.
4. RFI Immunity: IEC 801-3.
5. Ground Continuity: IEC 801-5.
6. Electrostatic Discharge: IEC 801-2.
7. Electromagnetic Field: IEC 61000-4-3.
8. Fast transients: IEC 61000-4-4.

2.2 PLC SCHEDULE

- A. PLC from the existing pump station RTU panels will be relocated to the new Pump Control Panel.

2.3 PROGRAMMING SOFTWARE

A. Programmable Logic Controller - Large

1. Manufacturer: Allen-Bradley RSLogix 5000, RSLinx, and network module software.
2. Licenses: Provide 1 License. Request Owner / City licensee information prior to ordering for registration.

B. Programmable Logic Controller - Small

1. Manufacturer: Allen-Bradley RSLogix 500, RSLinx, and network module software.
2. Licenses: Owner has licensed copy for their use.

2.4 CONTROL PANEL FABRICATION

- A. Refer to Section 40 95 16.
- B. Detail shop drawings showing field connections and any terminal block jumpering required.
- C. Terminate all used and spare I/O wiring to terminal blocks.
- D. Create wire markers with "to-from" component name, PLC slot/base, or terminal column number and terminal number information identical at each end.

- E. Provide terminal blocks for field connections to PLC Discrete Inputs:
 - 1. One fused terminal with LED for each group of 8 inputs, connected to control power.
 - 2. Fused terminal connected to eight terminal blocks to provide power to each field input circuit.
 - 3. One terminal per PLC input.
 - 4. One common terminal for each group of 8 inputs, connected to control power common.
- F. Provide terminal blocks for field connections to PLC Discrete Outputs:
 - 1. One fused terminal with LED for each output, connected to control power.
 - 2. Provide interposing relay for each solid-state PLC output. Connect output and control power common to relay coil. Provide two terminals for relay contact, normally opened unless otherwise noted.
 - 3. One common terminal for each output, connected to control power common.
- G. Provide terminal blocks for field connections to PLC Analog Inputs:
 - 1. One fused terminal with LED for each input, connected to +24 Vdc.
 - 2. Two terminals per PLC input.
 - 3. One common terminal for each input, connected to 24 Vdc common.
 - 4. One ground terminal for each input shield, connected to signal ground bus.
 - 5. Two surge protecting terminals for each field mounted instrument or equipment, grounded to the frame ground bus.
- H. Provide terminal blocks for field connections to PLC Analog Outputs:
 - 1. One fused terminal with LED for each output, connected to +24 Vdc.
 - 2. Two terminals per PLC output.
 - 3. One common terminal for each output, connected to 24 Vdc common.
 - 4. One ground terminal for each output shield, connected to signal ground bus.
 - 5. Two surge protecting terminals for field mounted equipment, grounded to the frame ground bus.

2.5 ETHERNET SWITCH

- A. Provide a network Ethernet switch to provide connectivity as shown on the network diagram. Provide the switch with the following minimum features:
 - 1. N-TRON 306TX Series, Phoenix Contact, or equal
 - 2. Rugged Industrial Enclosure
 - 3. DIN-Rail Mountable
 - 4. Six (6) 10/100BaseTX RJ-45 ports
 - 5. Plug and Play configuration
 - 6. Operating Temperature: 0° C to 60° C (32° F to 140° F)
 - 7. Operating Relative Humidity: 10% to 90% non-condensing

2.6 PANEL MOUNTED OPERATOR INTERFACE

- A. The panel mounted operator interface shall have the following minimum features:

1. 10-inch Color TFT, Touch Screen display
2. 640 x 480 resolution
3. 10/100Mbps Ethernet
4. 512mB RAM
5. Touchscreen
6. Keypad
7. NEMA 4X
8. Programming software: provide one license and associated documentation: Factory Talk View Studio Machine Edition.
9. Equipment shall be Panelview Plus 6 1000 with extended features (CAT. NO. 2117P-B10C4A9) as manufactured by Allen Bradley.

PART 3 EXECUTION

3.1 INSTALLATION

- A. Refer to Section 40 95 16.
- B. Connect input and output devices to the PLC via control panel terminal blocks, not directly to the PLC.

3.2 FIELD INSPECTION AND TESTING

- A. Refer to Section 40 95 16.
- B. Equipment Manufacturer and Systems Integrator
 1. The supplier of each PLC system shall provide a qualified service representative to perform the following:
 - a. Inspect the PLC installation including I/O and network systems, hardware configuration switch and jumper settings.
 - b. Monitor all PLC system diagnostic indicators, both hardware and software, and certify that the PLC system performance meets or exceeds the Manufacturer's published specifications.
 - c. Assist in all testing. The Systems Integrator will provide a minimum of one man-week on-site for each PLC I/O rack. Equipment Manufacturers shall provide a minimum of two man-days on-site per equipment assembly.
 - d. Modify PLC programs as required.
 - e. Certify in writing to the Engineer that the PLC system has been installed and configured in accordance with the Manufacturer's published guidelines. Equipment Manufacturer certification requirements are per the associated equipment Specification.
- C. Supplier
 1. Investigate and resolve fault or trouble conditions to the satisfaction of the PLC supplier.

3.3 TRAINING

- A. Operations and Troubleshooting

1. The Systems Integrator shall conduct application program maintenance, modification, and re-loading training. A minimum of four man-hours on-site including training materials and expenses shall be provided for three maintenance personnel.
2. Equipment Manufacturer training is per the associated equipment Specification.

3.4 PLC INPUT/OUTPUT SUMMARY

A. The Programmable Logic Controller I/O Summary provides a listing of PLC module requirements, and the assigned input/output points for the specified PLC system. The unassigned PLC I/O points shall be tagged as spare. The Programmable Logic Controller I/O Summary is included in Attachment A at the end of this Specification Section.

B. Programmable Logic Controller I/O Summary

1. The Programmable Logic Controller (PLC) I/O Summary provides a listing of the assigned input/output points to the specified PLC system.
2. The detailed assignment of I/O to specific points is provided for information only and will be revised and modified throughout the project. Final assignments shall be coordinated between the Supplier, the System Integrator, and the Owner during Construction.
3. Clarification of Headings:
 - a. Signal: The signal number consists of a two or three letter prefix (indicating the I/O point function) followed by a number identifying the process loop with which the I/O point is associated.
 - b. Description: Provides an abbreviated description of the function of the I/O point.
 - c. Source: Identifies field device that I/O point is connected to.
 - d. Drawings: Identifies the Drawings on which the I/O point is referenced.

3.5 ATTACHEMENTS

A. The following attachments are included as part of this Specification Section

1. PLC I/O Layout

PLC I/O Layout – Large Pump Station Control Panel (with panelview plus 1000 HMI)

I/O Point	Slot 0 (CPU)	Slot 1 (ENET)	Slot 2 (DI)	Slot 3 (DI)	Slot 4 (DI)	Slot 5 (DI)	Slot 6 (DI)
0			Pump 1 Auto Mode	Pump 2 Auto Mode	Pump 3 Auto Mode	Pump 4 Auto Mode	LSHH (No)
1			Pump 1 Run	Pump 2 Run	Pump 3 Run	Pump 4 Run	Future LSH
2			Pump 1 Fault	Pump 2 Fault	Pump 3 Fault	Pump 4 Fault	Future LSM2
3			Pump 1 Valve Open	Pump 2 Valve Open	Pump 3 Valve Open	Pump 4 Valve Open	Future LSM1
4			Pump 1 Valve Closed	Pump 2 Valve Closed	Pump 3 Valve Closed	Pump 4 Valve Closed	Future LSL
5			Pump 1 Low Discharge Pres.	Pump 2 Low Discharge Pres.	Pump 3 Low Discharge Pres.	Pump 4 Low Discharge Pres.	LSLL (No)
6			Spare	Spare	Spare	Spare	Spare
7			Spare	Spare	Spare	Spare	Spare
8							LSHH (So)
9							Future LSH
10							Future LSM2
11							Future LSM1
12							Future LSL
13							LSLL (So)
14							Spare
15							Spare
I/O Point	Slot 7 (CPU)	Slot 8 (ENET)	Slot 9 (DI)	Slot 10 (DO) MISC.	Slot 11 (DO)	Slot 12 (DO)	Slot 13 (AI)
0	Control Pwr On			Horn/Beacon	Pump 1 S/S	Pump 3 S/S	WW Level No. 1
1	UPS On			Chem P1 Run	Pump 1 Fault	Pump 3 Fault	WW Level No. 2
2	UPS Fault			Chem P2 Run	Pump 1 Valve O/C	Pump 3 Valve O/C	Flow, discharge
3	Gen. Auto			Odor Ctrl. On/Off	Spare	Spare	Station Load, current
4	Gen Run			Spare	Pump 2 S/S	Pump 4 S/S	Combust. Gas (ASHH)
5	Gen. Fault			Spare	Pump 2 Fault	Pump 4 Fault	Chem. Tank Level
6	Gen. Low Fuel			Spare	Pump 2 Valve O/C	Pump 4 Valve O/C	Gen. Fuel Level
7	ATS Norm/Emerg			Spare	Spare	Spare	Spare
8	Phase Loss						
9	Odor Ctrl. On						
10	Odor Ctrl. Fault						
11	Rain Gauge						
12	Spare						
13	Spare						
14	Spare						
15	Spare						

END OF SECTION

SECTION 40 95 16

INSTRUMENT AND CONTROL PANELS

PART 1 GENERAL

1.1 SUMMARY

A. Section Includes

<u>Paragraph</u>	<u>Title</u>
1.2	References
1.3	Submittals
1.4	Quality Assurance
1.5	Delivery, Storage, and Handling
1.6	Field Conditions
1.7	Warranty
2.1	Panel Design
2.2	Panel Schedule
2.3	Fabrication
2.4	Heating, Ventilating, and Cooling
2.5	Protection Coating and Finish
2.6	Nameplates
2.7	Panel Features
2.8	Surge Protection
2.9	Panel Grounding
2.10	Panel Drawing Protection
2.11	Direct-Current Power Supplies
2.12	Small Pump Station Control Panels
2.13	Uninterruptible Power System (UPS)
2.14	Spare Parts
3.1	General
3.2	Outdoor Panel Shade Covers
3.3	Panel Power Supply
3.4	Factory Testing
3.5	Field Testing

B. Scope

1. This section specifies requirements for panels for instrument, control, and communication equipment for the Gwinnett County Pump Station Project per the Panel Schedule herein.
2. Provide the instrument, control, and monitoring features indicated on the Example Control Panel Drawings and in the Specifications. Arrange panels to separate control

and instrument devices from power wiring. Arrange panel for dedicated field wiring terminations rated for 600 Vac or less for power, control, and instrument signal wiring shall be fabricated by a UL-508A recognized facility and shall bear the appropriate UL 508A Industrial Control Panel label. Panels for Hazardous (Classified) Locations shall bear the appropriate UL 698A label.

3. Transmitters, Analyzers, signal conditioning modules and other equipment or devices as specified in the other Division 40 sections.
4. Panels that contain programmable logic controllers (PLC) and operator interface stations (OIS) units shall be as indicated in the Panel Schedule. Specific panel devices are specified herein and in Section 26 00 02 – Basic Materials and Methods.
5. PLC and OIS shall comply with the specified products in Division 40. Panels that do not comply with the specified products and specified logic method, hardwired or PLC logic, shall not be accepted. Cost to retrofit the panel as specified shall be borne by the panel supplier. Corrections or modifications to UL 508A Industrial Control Panels shall be transported to the panel supplier’s facility for corrections, testing, relabeling and inspection.
6. Field modifications require a UL inspector site inspection for approval of panel corrections and to re-label the panel after the field modifications are completed.
7. Refer to Local Control Panels - Section 26 00 01 that specifies requirements for manufacturer, vendor, and Supplier provided panels that include motor controllers, combination motor starters, control devices, and logic devices as shown on the electrical drawings.
8. The control panels shall be assembled such that the existing backpanel from the existing RTU panel at each pump station can be relocated into the new Pump Control Panel, without changing the rating for the panel. A minimum 36” x 36” clear space shall be provided in the pump manufacturer supplied panel for mounting the backpanel from the existing RTU panel. No modifications to the pump manufacturer supplied panel shall be required for mounting the backpanel in it. If the backpanel will not fit without the need for modifications, the pump manufacturer shall retrieve the panel from the pump station site to return it to the panel manufacturer to have the necessary modification performed to accommodate the installation of the backpanel. The pump manufacturer shall be responsible for all costs associated with modifications to the panel, including retrieving the panel, shipping it to the panel manufacturer, and delivering the corrected panel to the pump station site. All costs for delays caused due to the pump manufacturer provided panel not having suitable space for the backpanel will be charged to the pump manufacturer, including installing contractor costs and bypass pumping costs.

C. Related Sections

1. Section 01 91 13 specifies Equipment and System Performance and Operational Testing with reference to Supplier’s Quality Assurance Manager that is responsible for startup commissioning of system including mechanical, HVAC, electrical, and instrumentation system.
2. Division 26 specifies raceways, conductors, and device requirements.
3. Section 40 94 43 specifies Programmable Logic Controller, Operator Interface Stations, and software requirements

1.2 REFERENCES

A. Reference Standards

1. This section contains references to the following documents that are part of this section as specified and modified. Where a referenced document contains references to other standards, those documents are included as references under this section as if referenced directly. In the event of conflict between the requirements of this section and those of the listed documents, the requirements of this section shall prevail.
2. Unless otherwise specified, references to documents shall mean the documents in effect at the time of Advertisement for Bids or Invitation to Bid or on the effective date of the Agreement if there were no Bids. If referenced documents have been discontinued by the issuing organization, references to those documents shall mean the replacement documents issued or otherwise identified by that organization or, if there are no replacement documents, the last version of the document before it was discontinued.
3. Where document dates are given in the following listing, references to those documents shall mean the specific document version associated with that date, regardless of whether the document has been superseded by a version with a later date, discontinued or replaced.

Reference	Title
EIA RS-310C	Racks, Panels, and Associated Equipment
NEMA 250	Enclosures for Electrical Equipment (1000 Volts Maximum)
UL 94	Tests for Flammability of Plastic Materials for Parts in Devices and Appliances
UL 508A	Industrial Control Panels
UL 698A	Industrial Control Panels Relating to Hazardous (Classified) Locations

1.3 SUBMITTALS

A. Action Submittals/Informational Submittals

1. Product Data
 - a. Marked product literature of all the enclosure electrical devices and components mounted on or within the control panel.
 - b. List of miscellaneous items, cables, spare and replenishment parts, and chemicals to be provided, including MSDS information.
2. Shop Drawings
 - a. A copy of the contract document Process and Instrumentation diagrams relating to the submitted equipment, with addendum updates that apply to the equipment in this section, marked to show specific changes necessary for the equipment proposed in the submittal. If no changes are required, the drawing or drawings shall be marked "no changes required".
 - b. Failure to include copies of the relevant drawings with the submittal shall be cause for rejection of the entire submittal with no further review.
 - c. Marked contract document Control Schematic diagrams related to the submitted equipment.
 - d. Marked contract document Control Single Line diagrams related to the submitted equipment.
 - e. Dimensioned drawings:
 - 1) Exterior panel and layout
 - 2) Interior devices and layout

- 3) Door-in-door construction devices, where required
- f. Panel assembly drawings including sections showing clearances between face and rear mounted equipment.
- g. Nameplate engraving schedule:
 - 1) Indicate engraving by line
 - 2) Character size
 - 3) Nameplate size
 - 4) Panel and equipment tag number and description
- h. Wiring drawings:
 - 1) Schematic diagrams
 - 2) Internal wiring diagrams
 - 3) Connection diagrams
- 3. Design Submittals
 - a. Heat load calculations for each cabinet based on the highest ambient temperature listed in Section 40 90 01 for the area in which the subject panel will be located.
- 4. Certifications
 - a. Manufacturer's certification for the performance of features of the specified equipment that cannot be readily inspected.
- 5. Special Procedure Submittals
 - a. A copy of this specification section, with addendum updates included, and all referenced and applicable sections, with addendum updates included, with each paragraph check-marked to indicate specification compliance or marked to indicate requested deviations from specification requirements. A check mark shall denote full compliance with a paragraph as a whole. If deviations from the specifications are indicated, and therefore requested by the Supplier, each requested deviation shall be underlined and denoted by a number in the margin to the right of the identified paragraph, referenced to a detailed written explanation of the reasons for requesting the deviation. The Engineer shall be the final authority for determining acceptability of requested deviations. The remaining portions of the paragraph not underlined will signify compliance on the part of the Supplier with the specifications.
 - b. Failure to include a copy of the marked-up specification sections, along with justification for requested deviations from the specification requirements, with the submittal shall be sufficient cause for rejection of the entire submittal with no further consideration.
- B. Closeout Submittals
 - 1. Operation and Maintenance Data
 - a. Manufacturer's operation and maintenance information as specified in Section 01 78 23. Include final reviewed submittal and separate record of all final configuration, jumper, and switch settings in the Manual.
 - b. Installation and training forms specified in Part 3.

1.4 QUALITY ASSURANCE

A. Certifications

1. Equipment and components shall be Underwriters Laboratory (UL) listed for the purpose per Section 26 00 01 or UL recognized.
2. Provide control panels with factory applied UL 508A labels. Where intrinsic safety barriers are used within a control panel, provide UL 698A factory applied label as required by UL.

1.5 DELIVERY, STORAGE, AND HANDLING

A. Delivery and Acceptance Requirements

1. Ship and protect equipment in accordance with the requirements specified in Section 01 65 00.

1.6 FIELD CONDITIONS

A. Refer to Section 40 90 01.

1.7 WARRANTY

A. Manufacturer Warranty

1. In addition to the guarantee specified in the General Conditions, provide a one (1) year warranty from the date of acceptance by the Owner and Engineer.

PART 2 PRODUCTS

2.1 PANEL DESIGN

- A. General: Panel hardware and software is specified in other Division 40 sections.
- B. The control panel shall be designed to accommodate relocation of the existing RTU backpanel from the existing RTU panel to the new Pump Control Panel. A minimum 36" x 36" space shall be provided in the new Pump Control Panel, on the controls side of the panel, for the RTU backpanel. No modifications to the Pump Control Panel shall be required for mounting the backpanel in it. If the backpanel will not fit without the need for modifications, the pump manufacturer shall retrieve the Pump Control Panel from the pump station site to return it to the Pump Control Panel manufacturer to have the necessary modification performed to accommodate the installation of the backpanel. The pump manufacturer shall be responsible for all costs associated with modifications to the Pump Control Panel, including retrieving the panel, shipping it to the panel manufacturer, and delivering the corrected panel to the pump station site. All costs for delays caused due to the Pump Control Panel not having suitable space for the backpanel will be charged to the pump manufacturer, including installing contractor costs and bypass pumping costs.
- C. Control Power Distribution: Use the din-rail power distribution method with fuses and blown fuse indication for panels containing 120-volt powered equipment. Power is restricted to 120 Vac and 24 Vdc.
- D. Power Supplies: Panels containing direct current powered instruments or serving as the termination point for transmission loop powered field instruments shall contain direct current power supply system as specified herein.
- E. Air Supplies: Provide each panel containing pneumatically operated instruments with a dual service regulator and distribution manifold, and all other devices necessary to perform the functions specified. Provide air distribution and control devices as specified.
- F. Electrical Control Devices: Pushbuttons, indicating lights, relays, and similar equipment located in panels specified in this section shall comply with the requirements of Section 26 00 02.

- G. Uninterruptible Power Supplies: Panel mounted 120 Vac input and 120 Vac output are specified herein.
- H. Mission Communications RTU: Make provisions in the panel for the owner to install a Mission Communications Mission MyDro. This device will be installed inside the pump station control panel and be connected to a dedicated high level float.
- I. Backup control logic: Pump station control panels shall contain backup hardwired control logic for rudimentary control of the pumps during a failure of the PLC control system. This logic shall be interlocked with the PLC_RUNNING relay. This relay shall disable the backup control logic whenever the relay is energized. Upon the relay becoming de-energized the backup control logic shall be engaged. This logic shall have the ability to run the pumps based on level controls. No pump alternation or pump fault procedure is necessary for this mode as it is an emergency backup. An example of this configuration is shown in the attached pump station control panel documents.
- J. Pump Station Control Panels located outside shall be NEMA-4X with a Factory applied white TGIC polyester urethane powder coating electrostatically applied to all outside and inside surfaces.

2.2 PANEL SCHEDULE

	PanelNo.	Spec / P&ID	Features *	Enclosure Type	Panel Title	/ Notes
1	CP-1000	40 95 16	1, 2, 3, 5, 8	Outdoors: NEMA-4X, painted white	Pump Control Panel	Provided by pump supplier
2	SMALL PUMP STATION RTU	40 95 16	1, 2, 3, 5	NEMA-4X, Painted White	Pump Station Control Panel	Provided by Owner to relocate to CP- 1000

1* - Programmable Logic Controller (PLC) or Remote I/O devices
 2* - Panel mounted Operator Interface Station (OIS)
 3* - Hardwired control logic required
 4* - Windowed outer door and inner door for displays or devices.
 5* - UPS
 6* - Fans
 7* - Heating
 8* - Air Conditioning
 9* - Sun/Rain Hood

2.3 FABRICATION

A. General

1. Design panels for the seismic requirements of Section 40 90 01. Brace structures, equipment, and devices to prevent damage from specified forces. Equipment panels shall be capable of operation following a disturbance.
2. Provide nameplates with tag number and equipment description to identify face-mounted instruments. Mount instruments for access to components and ease of removal. Blank off cutouts for future equipment with suitable covers. Identify instrument tag numbers on the panel rear.
3. Face-mounted equipment shall be flush or semi-flush with flat-black escutcheons. Face-mounted instruments that are more than 6 inches deep, weigh more than 10 pounds, or exert more than a 4 ft-lb moment force on the face of the panel shall be supported underneath at the rear by a 1-inch x 1/8-inch thick steel angle.

4. Provide floor stands for panels less than 60 inches high to raise the top of the panel to 60 inches above the floor or work platform. Panels that weigh less than 100 pounds may be wall mounted.
5. Panels with specified requirements including stainless steel or aluminum mounting requirements that are indicated on the project drawings or on the project details take precedence over the panel types or panel features indicated herein.

B. Panel Layout

1. See Example Control Panel Drawings provide in the Appendix.
2. Provide 20 percent spare contiguous sub-panel area for future expansion.
3. Provide minimum of 20 percent spare terminal blocks, with a minimum of 10 analog, discrete, power.
4. Provide minimum of 12 inches clear space from the bottom of the panel to the bottom of the subpanel.

2.4 HEATING, VENTILATING, AND COOLING

- A. Provide forced air ventilation for panels where indicated in the Panel Schedule and if the cabinet's heat-load calculations (based on heat generated by equipment within the panel and the exterior temperature of 120 degrees-F, 100% humidity, and full sun exposure) indicate that the interior temperature of the cabinet will exceed 90 degrees-F, under worst case conditions.
- B. Ventilation for panel racks shall be venturi fans provided on 5-1/2-inch high-notched panel. Ventilation for consoles shall be similar to that for panel racks except EIA RS-310 mounting is not required. Fans shall be equipped with UL-approved washable filters and provide at least 240 cubic feet per minute (CFM). Fans shall be thermostatically controlled. Noise level at 3 feet from exterior wall and 30 degrees off axis shall not exceed 60 NC units.
- C. Provide outdoor panels with thermostatically controlled space heaters. Space heater surface temperature that exceeds 120 degrees F requires an expanded metal guard. Thermostats shall be Honeywell T631B1013, Penn Controls A28AA-4, or equal.
- D. Panel air conditioning cooling requirements shall be a cooling system that does not exchange cabinet interior air with ambient air. The cooling system shall be either a closed glycol loop heat exchange system or a CFC-free refrigeration system as required for the specified equipment and instrument complement and ambient temperature conditions. The air conditioner shall be sized based on the heat-load calculations (heat generated by equipment within the panel and the exterior temperature of 120 degrees-F, 100% humidity, and full sun exposure) to cool the entire interior of the panel volume to maintain an interior temperature under 90 degrees-F, under the maximum ambient conditions.
- E. Panel air conditioner shall be NEMA rated based on the installed area environment and the coils shall be Heresite, or equal coated and protected from corrosion.

2.5 PROTECTION COATING AND FINISH

- A. Panels located outdoors or located in corrosive areas shall be bottom coated with waterproof coatings.

2.6 NAMEPLATES

- A. Identify external door-mounted components and the panel description with plastic nameplates. Provide machine embossed metallic adhesive labels to identify tag number of instruments inside panels. Attach nameplates to panel surfaces, not to instruments.

- B. Provide machine engraved laminated black phenolic nameplates with white lettering for panel-mounted equipment. Include the instrument tag number and description in 3/32-inch minimum size lettering on nameplate engraving.
- C. Attach the nameplates to the panel with a minimum of two self-tapping 316 stainless steel screws. Provide RTV sealant for nameplates for NEMA-4X stainless steel panels.
- D. The nameplate wording may be changed without additional cost or time prior to commencement of engraving. Submit nameplate legend with the panel submittal.

2.7 PANEL FEATURES









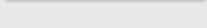

A. Interconnection Wiring:

1. Panel Interconnecting Wiring:

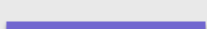
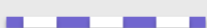
- a. Panel control wiring: Single conductor stranded copper NFPA No. 70 Type MTW No. 16 AWG minimum, with an exception for factory supplied PLC wiring harnesses that are U.L. approved.
- b. Panel instrument wiring: Twisted No. 16 AWG shielded pair or tri conductors.
- c. Panel power wiring: Conductors specified in Division 26 and meet the NFPA No. 70 NEC requirements for power including phase, grounded, and grounding conductors.
- d. Support wiring independently of terminations by lacing to panel support structure or by slotted flame retardant plastic wiring channels.
- e. Provide wiring channels complying with UL 94, Type V.
- f. Wiring channel fill not to exceed 50 percent.

B. Conductor Identification:

- 1. Tag wiring at terminations with machine printed plastic sleeves with three-part wire numbers for instrument and control panel internal conductors:
 - a. Part-1: Prefix of the wire number shall be the instrument loop number or equipment tag number.
 - b. Part-2: Code letter and wire colors per the following tables.
 - c. Part-3: Number that identifies individual circuit conductor [Rung Number] [Terminal Number].

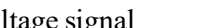
Code	Conductor	Color	
L	120VAC Power	Black	
C	120VAC Control	Red	
N	120VAC Neutral	White	
PG	120VAC Ground	Green	
PS	24 Vdc Power	Blue	
PG	24 Vdc Common	White/Blue	
PS	12 Vdc Power	Violet	
PG	12 Vdc Common	White/Violet	
S+	24 Vdc Signal (+)	Black	
SG	24 Vdc Signal (-)	White or Clear	
D	24 Vdc Control	Blue	
EG	Equipment Ground	Green	
FV	Panel Foreign AC Voltage	Yellow	
IS	Intrinsically Safe Circuits	Light Blue	

C. Conductor Installation and Protection

1. Carry power and control wiring in covered channels separate from low voltage signal circuits. Provide an interior steel barrier between AC control devices and the electronic equipment.
2. Provide strap screw type terminal blocks rated for 600 volts. Provide each terminal strip with a unique identifying alphanumeric code at one end and a vinyl-marking strip running the entire length of the terminal strip with a unique number for each terminal. Use 1/8 inch high machine printed numbers.
3. No more than two connections shall be made to one terminal.
4. Wire connectors shall be locking fork tongue or ring tongue insulated crimp type terminals.
5. Terminal blocks shall be;
 - a. Buchanan 0621-1
 - b. Allen-Bradley 1492-HM1 600 V 30-amperes, finger-safe terminal block.
 - c. Allen-Bradley 1492-CD3 600 V 35-amperes with #8 screw terminal block for ring or spade terminals.
 - d. Phoenix Contact, Weidmuller, or engineer approved equal products.

D. Field Wiring

1. Connect field wiring to separate dedicated terminal blocks in a dedicated part of the panel where the field cables enter the panel.

E. Fuse and Fuse Holders

1. Fuses for 120 Vac circuits shall have a minimum of 12,000-amperes interrupting capacity and blown fuse indicators.
2. Fuses for 24 Vdc circuits shall be fast acting glass tube type rated 1/8 or 1/10 amp for 4-20 mA loops.
3. Fuses for 24 Vdc circuits shall be 1/2 amp for the power supply to individual instruments.
4. Fuse holders shall be tip-out or draw-out type.

5. Provide Phoenix Contact or engineer approved equal products.

F. Control Power:

1. 120 Vac control power source: Single power source for all control and DC power. Dual power sources, one for control power and one for DC power. Dual power sources, one for PLC and DC power and one for PLC output [and input] control power.
 - a. Provide control power transformers, as required for the load.
 - b. Provide direct current power supplies, as required for the load.
 - c. Provide UPS for PLC and derived loop power as defined above, as required for the load.

G. Panel Power:

1. Panel power source:
 - a. Provide a 120 Vac circuit for the panel light, receptacle, heating, fan, heat exchanger, or air conditioner cooling load as required.

H. Accessories:

1. Provide GFCI convenience receptacles and fluorescent utility lights in panels greater than 24" high x 24".
2. Do not power receptacles and utility lights by the UPS, where included.
3. Print pocket.
4. Fold-up shelf of sufficient size, sufficient weight capacity, and the proper angle for supporting a laptop computer.

2.8 SURGE PROTECTION

A. Provide multi-stage, plug-in type surge protectors selected to protect the equipment. Surge protectors shall be removable without changing the impedance of the circuit. Surge protectors product manufactures shall be:

1. Circuit Components Inc: Din Rail SDD-400 Series for Data or Analog Signals.
2. Circuit Components Inc: SPD-Series at the 120 AC incoming power.
3. Joslyn Model 1663-08
4. Taylor 1020FA
5. Phoenix Contact
6. Telematic
7. Edco
8. Or engineer approved equal.

2.9 PANEL GROUNDING

A. Provided two copper ground bars in each panel.

1. Bond one bar (NEC required) to the panel or panel frame or back-plate and to the facility grounding system.
2. Mount the second (signal) ground bar on insulated stand-offs and bond to the panel ground bar only at one point.

B. Bond signal circuits, signal cable shields, and low-voltage DC power supply commons to the signal ground bar.

- C. Only ground the field analog wiring shields at the signal ground bar. Test to verify that single ground point at panel signal ground bar.
- D. Bond surge protectors and separately derived AC power supplies to the frame ground bar.
- E. For panels exceeding 36 inches in width, provide 1/4- by 1-inch copper ground bars extending the entire length of the panel interior at the bottom of the panel.

2.10 PANEL DRAWING PROTECTION

- A. Provide wiring diagrams in accordance with Section 01 33 23. Provide a panel-wiring diagram and schematic for each panel in a plastic bag or plastic container to avoid water damage and aging.

2.11 DIRECT-CURRENT POWER SUPPLIES

- A. Nominal 24-volt direct-current instrumentation and control power supply:
 - 1. Convection-cooled linear type or switching type.
 - 2. Line regulation: 0.4 percent for line variations from 105 to 132 volts.
 - 3. Load regulation: 0.4 percent for load variations from 0 to full load.
 - 4. Ripple and noise: Not exceed 100 mV peak-to-peak.
 - 5. Hold-up time at maximum load: Not less than 16 milliseconds.
 - 6. Continuous duty from 0 to 50 degrees C at rated load.
 - 7. Output electronically current limited.
 - 8. Over-voltage crowbar shutdown.
 - 9. Output voltage:
 - a. Rated 28 Vdc
 - b. Adjustable plus or minus 5 percent
 - c. Set to provide 26.4 volts to the panel direct current bus.
 - 10. Power Supply: Lambda LZS series, or engineer approved equal.

2.12 SMALL PUMP STATION CONTROL PANELS (PSCP)

- A. General Requirements
 - 1. All equipment furnished under this section shall be selected for its superior quality and intended performance. Equipment and materials used shall be subject to review and shall comply with the following requirements.
 - a. Unless specified otherwise, electrical power supply to the instrumentation equipment will be unregulated 120 volts ac at the locations noted on the one-line and functional diagrams. All transmitted electronic analog instrument signals shall be 4-20 mA dc, unless noted otherwise, and shall be linear with the measured variable.
 - b. Cabinet Construction and Interior Wiring: In accordance with the National Electrical Code (NEC), state and local codes, and applicable sections of NEMA, ANSI, UL, and ICEA.
 - c. PSCP shall include physical barriers inside panel to prevent accidental access between telemetry and pump control areas of the panel.
 - d. Control panel shall be fabricated at the system integrator's panel shop. No field fabrication is allowed.

- e. Cabinet shall be built to UL 508 standards and bear UL listing mark stating "LISTED ENCLOSED INDUSTRIAL CONTROL CABINETS".
- B. Pumps 15HP or Greater
1. Use soft starters with 120 VAC coil control.
 2. Have soft stop capability.
 3. Include integral bypass contactor.
 4. Isolation contactor is not required unless specified by the engineer.
 5. Have overload protection capability.
 6. Display current.
 7. Soft start display shall be remotely mounted on inner door of cabinet.
- C. Enclosure
1. Enclosure Type: NEMA 4X.
 2. Materials: Type 316 stainless steel.
 3. Metal Thickness: 14-gauge, minimum.
 4. Doors: Rubber-gasket with continuous hinge. Stainless steel lockable quick-release clamps.
 5. Provide a lockable handle on the outside of each door.
 6. Size cabinet to allow access around all the instruments for ease of operation and maintenance.
 7. Design cabinet to prevent overheating of instruments in accordance with paragraph 2.4, above.
 8. Include a heater unit with thermostat control for protection of cabinet equipment. Design heater for an ambient air temperature of 10 degrees Fahrenheit with 100% humidity (non-condensing).
 9. Control panel shall be a 72"H x 72"W x 18"D NEMA 4X stainless steel enclosure with dual dead front doors. The control panel shall be laid out as shown on the included Example Control panel Drawings. If additional space is required to house this equipment the panel depth or width may be increased. However, under all circumstances, the control/telemetry section of the panel shall be on the left side with a physical barrier between the power supply (breakers, pump starters, and protection equipment) which shall be behind the right door. The panel configuration shall be such that it is not possible to access the power side of the panel when only the left hand door is open to the control side of the panel.
 10. Factory applied white TGIC polyester urethane powder coating electrostatically applied to all outside and inside surfaces.
 11. Manufacturers: Hoffman Engineering Co., Saginaw, or engineer approved equal
- D. Inner Door Indicator Lights
1. As shown on Example Control Panel Drawings, mount the following items on the inner door of the PSCP:
 - a. Pump Hand-Off-Auto switch
 - b. Pump Run Light (Red)
 - c. Pump Failure Light (Amber)

- d. Pump Stop Light (Green)
 - e. Flygt MAS unit operator interface (if applicable)
 - f. Soft Start operator interface (if applicable)
 - g. Pump stations shall have a six digit non-resettable elapsed time meters for each pump to show individual pump running time to the 1/10th of an hour.
 - h. Engraved lamicoid nameplate with RTU number and station name.
- E. Control Power Transformer
- 1. Install control power transformer(s) inside the panel in the motor control section. Size the transformer at 125% of the rated load and rated for machine tool service.
- F. Cabinet Wiring
- 1. Provide wiring within cabinets meeting the following requirements:
 - a. Wires for AC circuits shall be 600 volt, Type THHN stranded conductor copper and shall be sized for the current to be carried, but not smaller than No. 16 AWG.
 - b. Wires for analog signal circuits shall be 300 volt stranded copper and shall be twisted shielded pars not smaller than No. 16 AWG.
 - c. Wires for other DC circuits shall be 600 volt, Type THHN stranded copper not smaller than No. 16 AWG.
 - d. Wiring shall be numbered and tagged at each termination on both ends.
 - e. Wiring for special signals such as communications, digital data and multiplexed signals shall use manufacturer's standard cables.
 - f. All control wiring shall be stranded. No solid wire shall be allowed, except that the telemetry may be 22-gauge multi-pair telephone cable.
 - g. Restrain by plastic ties or wire management system.
 - h. Hinge Wiring: Secure at each end so that bending or twisting will be around longitudinal axis of wire. Protect bend area with sleeve.
 - i. Arrange wiring neatly, cut to proper length, and remove surplus wire.
 - j. Provide abrasion protection for wire bundles that pass through holes or across edges of sheet metal.
 - k. Provide wire labels at both ends of terminated wire.
 - l. If cellular communications is deemed to be unavailable, provide one RJ-11 telephone jack in the control panel. Phone wire from telephone interface to jack to be gel filled direct burial cable.
- G. Compression Clamp Type Terminals
- 1. Strip, prepare, and install wires in accordance with terminal manufacturer's recommendations.
 - 2. Wires installed in a compression screw and clamp, maximum of one for field wires entering enclosure, otherwise maximum of two.
 - 3. Splicing and tapping of wires, allowed only at device terminals or terminal blocks.
 - 4. Separate analog and dc circuits by at least 6 inches from ac power and control wiring, except at unavoidable crossover points and at device terminations.
 - 5. Arrange wiring to allow access for testing, removal, and maintenance of circuits and components.
 - 6. Plastic Wire Duct Fill: Do not exceed manufacturer's recommendations.

H. Terminal Blocks

1. Provide sufficient terminations to accommodate both present and future needs. Wire spare PLC module I/O points to their Cabinet's terminal blocks. Provide 300 volt screw clamp compression, dead-front barrier type terminal blocks with current bar providing direct contact with wire between the compression screw and yoke. Provide yoke, current bar and clamping screw constructed of high strength and high conductivity metal. Use yoke that guides all strands of wire into the terminal. Use current bar providing vibration proof connection. Supply terminals that allow connection of wire without any preparation other than stripping. Rail mount individual terminals to create a complete assembly.
2. Provide terminal constructed such that jumpers can be installed with no loss of space on terminal or rail.
3. Size all terminal block components to allow insertion of all necessary wire sizes and types. Supply terminal blocks with marking system allowing the use of UL approved terminal blocks manufactured by Allen Bradley, Cutler Hammer, Phoenix Contacts or engineer approved equal.

I. Grounding

1. Cabinets isolated copper grounding bus for all signal and shield ground connections. This ground bus shall be grounded at a common ground point. The signal grounding system shall meet National Electrical Code requirements.
 - a. Ground each analog loop at a single point for the loop. This single point shall be at location of the DC power supply for the loop.
 - b. Each analog loop shall have its wire shields connected to ground at a single point for the loop.
 - c. Discrete signals between cabinets shall be dry isolated contacts rated for 5 amps continuous at 120 V AC.

J. Network Cables

1. Network cables will be as required for a complete and operational system.

K. Electrical Transient Protection

1. General

- a. Protect all elements of the PSCP against damage due to electrical transients induced in interconnecting lines by lightning and nearby electrical systems. As a minimum, provide surge suppressors at the following:
 - 1) At any connection at AC power to PSCP.
 - 2) At the radio transmission line bulkhead entrance.
 - 3) At analog or digital monitoring or controls (DI, DO and AI).
 - 4) Output of DC power supply.
 - 5) Ethernet cables.

2. Suppressor on 120 Vac Power Supply Connections

- a. Construction: First stage high energy metal oxide varistor and second stage bipolar silicon avalanche device separated by series impedance. Grounding wire, stud or terminal provided.
- b. Occurrences: Suppressor tested and rated for a minimum of 50 occurrences of IEEE 587 Category B test waveform.

- c. Clamping voltages: 350 volts or less for first stage, 210 volts or less for second stage.
 - d. Response: 5 nanoseconds maximum.
 - e. Recovery: Automatic
 - f. Continuous operation: 5 amps minimum at 130 volts AC for suppressor on power supply for one (1) 4-wire transmitter or receiver, 20 amps minimum otherwise.
 - g. Temperature range: -20 degrees C to + 85 degrees C.
 - h. Manufacturers: EDCO HSP-121, Phoenix Contact FSP-1, Schneider Electric TVS120LC, or engineer approved equal.
3. Suppressor on Analog Signal Lines
- a. Construction: First stage high energy metal oxide varistor and second stage bipolar silicon avalanche device separated by series impedance. Grounding wire, stud or terminal provided.
 - b. Test waveform: Linear 8 microsecond rise in current from zero amps to a peak current value followed by an exponential decay of current reaching for half the peak value in 20 microseconds.
 - c. Surge rating: Suppressor tested and rated for a minimum of 50 occurrences of 2000 amp peak test waveform.
 - d. DC clamping voltage: Twenty to forty percent above operating voltage for circuit. Clamping voltage tolerance less than plus or minus 10 percent.
 - e. Response: 5 nanoseconds.
 - f. Recovery: Automatic.
 - g. Maximum loop resistance: 18 ohms per conductor.
 - h. Temperature range: -20 degrees C to + 85 degrees C.
 - i. Approved vendor EDCO PC-642 or SRA-64 Series or engineer approved equal.
4. Main Service Surge Suppressor
- a. Provide a surge suppressor at the power service entrance installed nipped to the main service disconnect switch. The surge suppressor shall meet UL 1449 as a Type 1 SPD and connected to the line side of the main disconnect. The surge suppressor shall have voltage characteristics to match the power service.
 - 1) The surge suppressor shall be in a NEMA-4X stainless steel enclosure and shall provide line to line, line to neutral, line to ground and neutral to ground protection modes as applicable for the power service.
 - 2) The surge suppressor shall be provided with an integral disconnect separate from the main breaker. Minimum surge current rating shall be 1KA per mode, 200KA per phase per NEMA LS-1. The surge suppression system shall be duty cycle tested to survive 20KV, 20KA, IEEE C62.41 category surge current with less than 5% degradation of clamping voltage. The surge suppressor shall have minimum repetitive surge capacity of 6500 impulses per mode. Status indicating lights and form 'C' dry alarm contacts shall be provided. An event counter display shall be provided.
 - 3) The surge suppressor shall be U.L. listed and labeled under UL1449 and UL1283. Acceptable manufacturers are Liebert, Current Technology, or Innovative Technology.

5. Phase Monitor

- a. Provide a phase monitor in the pump control panel. The pump operation shall be inhibited when an open phase/phase reversal condition is detected. A contact of the phase monitor shall also be wired to the PLC for remote indication of the open phase/phase reversal condition.

L. Cabinet Fabrication

1. Power Distribution within Cabinets
 - a. One 120 V AC, 60-Hz feeder circuits.
 - b. Make provisions for feeder circuit conduit entry.
 - c. Furnish terminal board for termination of wires.
 - d. Provide 120 VAC Circuit Breaker in each cabinet for incoming AC Power.
2. Signal Distribution
 - a. Within Cabinets: 4 to 20 mA dc signals may be distributed as 1 to 5V dc.
 - b. Outside Cabinets: Isolated 4 to 20 mA dc only.
 - c. All signal wiring shall be twisted shielded pairs.
3. Signal Switching
 - a. Use dry circuit type relays or switches.
 - b. No interruption of 4 to 20 mA loops during switching.
 - c. Switching Transients in Associated Signal Circuit:
 - d. 4 to 20 mA dc Signals: 0.2 mA, maximum.
 - e. 1 to 5V dc Signals: 0.05V, maximum.

M. Relays

1. General
 - a. Relay Mounting: Plug-in type socket.
 - b. Relay Enclosure: Furnish dust cover.
 - c. Socket Type: Screw terminal interface with wiring.
 - d. Socket Mounting: Rail.
 - e. Provide hold-down clips.
2. Signal Switching Relay
 - a. Type: Dry circuit.
 - b. Contact Arrangement: 2 Form C contacts.
 - c. Contact Rating: 10 amps at 28V dc or 120V ac.
 - d. Contact Material: Gold or silver.
 - e. Coil Voltage: As noted or shown.
 - f. Coil Power: 0.9 watts (dc), 1 .2VA (ac).
 - g. Expected Mechanical Life: 10,000,000 operations.
 - h. Expected Electrical Life at Rated Load: 100,000 operations.
 - i. Indication Type: Neon or LED indicator lamp.
 - j. Seal Type: Hermetically sealed case.
 - k. Manufacturer: Potter and Brumfield; Allen Bradley, Siemens or Cutler Hammer or engineer approved equal.

3. Control Circuit Switching Relay, Non-latching
 - a. Type: Compact general purpose plug-in.
 - b. Contact Arrangement: 2 Form C contacts.
 - c. Contact Rating: 10A at 28V dc or 240V ac.
 - d. Contact Material: Silver cadmium oxide alloy.
 - e. Coil Voltage: As noted or shown.
 - f. Coil Power: 1.8 watts (dc), 2.7VA (ac).
 - g. Expected Mechanical Life: 10,000,000 operations.
 - h. Expected Electrical Life at Rated Load: 100,000 operations.
 - i. Indication Type: Neon or LED indicator lamp.
 - j. Push-to-test button.
 - k. Manufacturer and Product: Allen Bradley 700-HC14A1, or engineer approved equal.
4. Control Circuit Switching Relay, Latching
 - a. Type: Dual coil mechanical latching relay.
 - b. Contact Arrangement: 2 Form C contacts.
 - c. Contact Rating: 10A at 28V dc or 120V ac.
 - d. Contact Material: Silver cadmium oxide alloy.
 - e. Coil Voltage: As noted or shown.
 - f. Coil Power: 2.7 watts (dc), 5.3VA (ac).
 - g. Expected Mechanical Life: 500,000 operations.
 - h. Expected Electrical Life at Rated Load: 50,000 operations.
 - i. Manufacturer: Potter and Brumfield, Siemens or Allen Bradley or engineer approved equal.
5. Power Supplies
 - a. Furnish as required power to instruments requiring external dc power, including two-wire transmitters and dc relays. Regulated dc power supplied for instrument loops shall be provided. Power supplies shall be suitable for an input voltage variation of +/- 10 percent, and the supply output shall be fused or short-circuit protected. Output voltage regulation shall be as required by the equipment supplied.
 - b. Convert 120V AC, 60-Hz power to dc power of appropriate voltage(s) with sufficient voltage regulation and ripple control to assure that instruments being supplied can operate within their required tolerances.
 - c. Provide output over voltage and over current protective devices to protect instruments and power supplies from damage due to power supply or external failure.
 - d. Enclosures: NEMA 1.
 - e. Mount such that dissipated heat does not adversely affect other components.
 - f. Supply indicating-type fuses for each dc supply line to each individual two-wire transmitter and mount so fuses can be easily seen and replaced.
 - g. Include fused push-to-test circuitry for each push-to-test indicating light.

- h. Provide internal cabinet light. Light shall be 100-watt fluorescent bulb and shall be operated by a door switch.
- i. Provide service outlet with a breaker protected 120-volt, 15-amp, GFCI duplex receptacle and weatherproof enclosure on the outside of the “mini power center” box or support.

N. Control Equipment

1. The Owner will have the backpanel and HMI from the existing Pump Station RTU panel relocated to the new Pump Control Panel to be provided by the pump Supplier.
2. The County will provide a standard PLC & HMI application program for the pump station PLC and HMI. Supplier will setup the software for the pump station, including configuring device ranges, IP address, motor current range, wet well level, set points and other settings, for a complete and operational PSCP.
3. Allen Bradley Micrologix 1400 PLC (1766-L32AWA)
 - a. 20 Digital Inputs, 120 VAC
 - b. 12 Digital Outputs, relay outputs
4. Digital Input Module (Allen Bradley 1762-IA8)
 - a. 8 Digital Inputs, 120 VAC
5. Analog Input Module (Allen Bradley 1762-IF4)
 - a. Inputs 4 differential 4-20 mA
6. Analog Input and Output Module (Allen Bradley 1762-IF2OF2)
 - a. Inputs 2 differential 4-20 mA
 - b. Outputs 2 single ended 4-20 mA
7. Allen Bradley PanelView Plus 600 Color with keypad and touch screen (2711P-B6C20A)
 - a. Screen: 5.5 inch
 - b. Combination touch and keypad
 - c. Ethernet Communication
 - d. RS-232 Communication
 - e. Power: 120 VAC
8. Programmable Logic Controller Functional Requirements: PLC Inputs and Outputs (I/O) are shown below. Provide inputs, outputs, functions, or operations required to provide a completely operational system. Note that this list does not show the PLCs diagnostic fault detection points which are nevertheless required.
9. Digital Inputs
 - a. DI-1 - Pump 1 Auto Mode (1=Auto, 0=Manual)
 - b. DI-2 - Pump 1 Run (1=On, 0=Off)
 - c. DI-3 - Pump 1 Fault (1=Fault Alarm, 0=Normal)
 - d. DI-4 – Odor Control Run (1=On, 0=Off)
 - e. DI-5 - Pump 2 Auto Mode (1=Auto, 0=Manual)
 - f. DI-6 - Pump 2 Run (1=On, 0=Off)
 - g. DI-7 - Pump 2 Fault (1=Fault Alarm, 0=Normal)

- h. DI-8 – Odor Control Fail (1=Fault Alarm, 0=Normal)
- i. DI-9 - Level Switch High (LSH) (0=Alarm, 1= Normal)
- j. DI-10 - Level Switch Lag Start (LSM3) (0=Alarm, 1= Normal)
- k. DI-11 - Level Switch Lead Start (LSM2) (0=Alarm, 1= Normal)
- l. DI-12 - Level Switch Pump Stop (LSM1) (0=Alarm, 1= Normal)
- m. DI-13 - Level Switch Low (LSL) (0=Alarm, 1= Normal)
- n. DI-14 - Phase Loss (0=Alarm, 1= Normal)
- o. DI-15 - Generator Auto (1=Auto, 0=Not Auto)
- p. DI-16 - Automatic Transfer Switch (0=Generator, 1=Normal)
- q. DI-17 - Generator Fault (0=Alarm, 1=Normal)
- r. DI-18 – Level Switch High High (LSHH) (0=Alarm, 1=Normal)
- s. DI-19 – Combustible Gas Alarm (0= High Alarm, 1=Normal)
- t. DI-20 – Cabinet Intrusion
- u. DI-21 – Station Intrusion [if available]
- v. DI-22 – UPS On
- w. DI-23 – UPS Fail
- x. DI-24 – Generator Run Status (1=On, 0=Off)
- y. DI-25 - Spare
- z. DI-26 - Spare
- aa. DI-27 - Spare
- bb. DI-28 - Spare

10. Digital Outputs

- a. DO -1 – Pump 1 Run (1= On, 0=Off)
- b. DO -2 – Pump 2 Run (1= On, 0=Off)
- c. DO -3 – Chemical Feed Pump 1 (1= On, 0=Off) [if available]
- d. DO -4 – Chemical Feed Pump 2 (1= On, 0=Off) [if available]
- e. DO -5 – Odor Control (1= On, 0=Off) [if available]
- f. DO -6 – Pole Lights (1= On, 0=Off) [if available]
- g. DO -7 – Spare
- h. DO -8 – Spare
- i. DO -9 – Spare
- j. DO -10 – Spare
- k. DO -11 – Spare
- l. DO -12 – Spare

11. Analog In

- a. AI – 1 Wet Well Level
- b. AI – 2 Flow Discharge [if available]
- c. AI – 3 Pump 1 Motor Current
- d. AI – 4 Pump 2 Motor Current

- e. AI – 5 Discharge Pressure [if available]
 - f. AI – 6 Generator Fuel Level [if available]
 - g. AI – 7 Combustible Gas Level
 - h. AI – 8 Spare
12. Analog Out
- a. AO – 1 Spare
 - b. AO – 2 Spare
 - c. AO – 3 Spare
 - d. AO – 4 Spare
13. The Owner shall provide all PLCs and associated equipment and cables to form a complete and functional controller with SCADA cellular monitoring, control and data logging capability as required for this project
14. Furnish and install all cables for interconnecting all components of the PLC inside the Cabinet. These cables shall include cables to network bridge, power supplies, central processing unit.
15. Furnish all network cables needed to interface all applicable PLCs with network.

2.13 UNINTERRUPTIBLE POWER SYSTEM (UPS)

- A. Provide a UPS that is online, computer-grade with electrical isolation including output neutral. Package UPS for panel enclosure mounting using a back-panel bracket or holder:
 - 1. Nominal input voltage: 120Vac.
 - 2. Nominal output voltage: 120Vac.
- B. The online UPS system shall be provided with integral sealed no maintenance batteries, sized to provide full capacity backup power for 30 minute minimum at connected load with integral battery charger.
- C. The panel supplier shall calculate the required kVA rating at 150 percent of connected load. Submit load calculations, schematic diagrams, and wiring connection diagrams. Provide battery cabling and other required cabling for a complete system.
- D. Mount the UPS within the panel on a pedestal or tray with stainless-steel legs to provide space for wire entry and passage.
- E. Uninterruptible power supply systems shall be as manufactured by Best Power Technology, Inc., Necedah, American Power Conversion, Wisconsin, or equal.

2.14 SPARE PARTS

- A. Provide the following spare parts:
 - 1. Ten each of each type of light bulb used in the panels.
 - 2. Five each of each type and rating of fuse used in the panels.

PART 3 EXECUTION

3.1 GENERAL

- A. Mount and shim floor mounted cabinets to precise alignment so doors operate without binding. Provide sealant for conduit entering the panels.

- B. Mount floor-mounted panels, except in dry control rooms or electrical equipment rooms, on 3-1/2-inch minimum height concrete pads or grouted bases as specified. Provide coating for outdoor panels in contact on concrete. Mount field panels and cabinets in compliance with Section 40 90 01, paragraph 3.1.B.
- C. Spray terminals and terminal blocks after all terminations have been completed with a silicone resin similar to Dow Corning R-4-3117 conformal coating.
- D. Provide panels with the Record As-built schematic, connection, and interconnection diagrams mounted behind plexiglass holder on the inside of the door. Place documentation in a water proof clear bag in the panel document holder.

3.2 OUTDOOR PANEL SHADE COVERS

- A. Fabricate the custom aluminum panel shade cover and mount the panels facing away from the prevailing sun or wind.
- B. Provide Sun/Rain covers per Electrical Detail for outdoor vendor, manufacture, and custom panels. Fabricate based upon known panel dimensions or accepted submittal drawing dimensions.

3.3 PANEL POWER SUPPLY

- A. Mount and connect power supply and conditioning equipment in compliance with the manufacturer's instructions.
- B. Provide line side disconnect switches for power supply and conditioning equipment. Provide line and load side overcurrent protection for power supply and conditioning equipment in compliance with NFPA 70. Disconnect switches shall comply with Section 26 00 02.
- C. Small power supply and conditioning equipment may be mounted in the panel served. Mount larger units adjacent to the equipment served. Where unconditioned power is brought into control panels, enclose it in metallic raceways within the panel.
- D. Provide sound isolators for power supply and conditioning equipment larger than 5 kVA load capacity supported from surfaces other than concrete.
- E. Use flexible conduit in compliance with Division 26 for final raceway connections.

3.4 FACTORY TESTING

- A. Assemble, interconnect, and functionally test the control panel at the assembly shop prior to shipment. The Owner/Engineer shall have the option of witnessing the functional shop test. Notify the Owner/Engineer at least two (2) weeks in advance prior of the scheduled functional shop test.

3.5 FIELD TESTING

- A. Field verify the following for Instrument and Control Panels:
 1. Control circuits grounded with one terminal of each load device connected to the grounded conductor.
 2. Control contacts installed in the ungrounded side of the circuit.
 3. Signal and control wiring installed in separate wireways.
 4. Barriers between the power wiring and the signal and control wiring.
 5. Connected to the plant grounding system, as specified.
 6. Center-line of wall-mounted panels shall be 48 inches above the floor.

7. Inner door contains a copy of the Record elementary and wiring diagrams.
8. Inner door contains a protected drawing holder.
9. Drawings enclosed in a transparent, protective jacket.
10. Functions as specified.
11. Mounted with stainless steel unistrut, fittings, and fasteners.
12. Tested in accordance with Section 26 00 01.

END OF SECTION

SUBMERSIBLE PUMPS

PART 1 GENERAL

1.1 SUMMARY

A. Section Includes

<u>Paragraph</u>	<u>Title</u>
1.2	Administrative Requirements
1.3	Submittals
1.4	Quality Assurance
1.5	Delivery, Storage, and Handling
1.6	Field Conditions
1.7	Warranty
2.1	Equipment
2.2	Electrical and Control Requirements
2.3	Accessories
2.4	Source Quality Control
3.1	Installation
3.2	Field Quality Control
3.3	Adjusting

B. Scope

1. Furnish, check installation, provide start-up services, test, and place in satisfactory operation heavy-duty, electric, submersible, non-clog, centrifugal pumps for the pump stations identified in compliance with the Specifications.

1.2 ADMINISTRATIVE REQUIREMENTS

A. Coordination

1. The Contract Documents are intended to describe a pump installation for the specified purpose, complete and ready to be placed into service at the levels of performance indicated herein. The Supplier will be required to coordinate with the Owner's installing Contractor for checkout, start-up and testing services, which will be required at later dates as scheduled by the Owner. By offering this service to the Owner, Supplier affirms that they are fully knowledgeable of the services to be provided for checkout, start-up and testing and will provide such services at the time requested by the Owner regardless of the duration between delivery of the pumps and control panel and installation of the furnished equipment.
2. Coordinate with other manufacturers and suppliers to provide all details and appurtenances necessary to properly install, adjust, and place in satisfactory operation a complete working unit.

1.3 SUBMITTALS

A. Action Submittals/Informational Submittals

1. Shop Drawings

- a. Submit the following items with the Shop Drawings in accordance with, or in addition to, the requirements specified in Section 01 33 23 – Shop Drawings, Product Data, and Samples and Section 01 60 00 – General Equipment Stipulations:
 - 1) Pump performance curves at rated speed and reduced speed (if reduced speeds are specified).
 - a) Indicate flow, head, efficiency, brake horsepower, NPSHr, and minimum submergence.
 - b) Include limits (minimum and maximum flows) for stable operation without cavitation, overheating, recirculation, or excessive vibration.
 - 2) General cutaway sections, materials, dimension of shaft projections, shaft and keyway dimensions, shaft diameter, dimension between bearings, general dimensions of pump, suction head bolt orientation, and anchor bolt locations and forces.
 - 3) Dimensioned installation drawings.
 - 4) Detailed description of construction, including a parts list with materials of construction and metallurgy with ASTM designations.
 - 5) Details of shaft sealing system.
 - 6) AISI grades of stainless steel for casing and impeller wear rings.
 - 7) Details of guide rail system, including pump manufacturer's recommended locations for intermediate and upper guide rail supports and mounting requirements.
 - 8) Functional description of internal and external instrumentation and controls, including a list of parameters monitored, controlled, or alarmed.
 - 9) Control panel elevation drawings showing fabrication and placement of operator interface devices and associated elements.
 - 10) Motor performance chart showing curves for torque, current, power factor, input/output power, and efficiency and data on starting and no-load characteristics.
 - 11) Product data sheets for power and control cables, including length of cables.

2. Manufacturer Reports

- a. Submit a certified report prepared by the manufacturer's technical representative certifying satisfactory installation, operation, and in-service placement of pumps.

B. Closeout Submittals

1. Operation and Maintenance Data

- a. Submit Operating and Maintenance Manuals in accordance with Section 01 78 23 – Operating and Maintenance Data.

2. Warranty Documentation

- a. Include the manufacturer's warranty in the compiled warranty submittal of all manufacturers' warranties in accordance with Section 01 78 33 – Warranties and Bonds.

C. Maintenance Material Submittals

1. Spare Parts

- a. Include manufacturer's information for the spare parts specified herein with the Shop Drawing submittal.
2. Tools
 - a. Include manufacturer's information for the special tools and supplies specified herein with the Shop Drawing submittal.

1.4 DELIVERY, STORAGE, AND HANDLING

A. Delivery and Acceptance Requirements

1. Ship components containing bearings with lubricant on all bearings.
2. Deliver all components to site in manufacturer's shipping crates or boxes.
3. Deliver to site undamaged.

B. Storage and Handling Requirements

1. Protect from corrosion and mechanical damage.
2. Protect electrical components from condensation.
3. Ship power and control cables with securely-attached caps on cable ends to prevent moisture wicking into cable during storage.
4. Store with lubricant on all bearings.
5. Handle all components in such a manner to prevent damage during unloading and installation.
6. Follow manufacturer's instructions regarding lifting and setting.

1.5 FIELD CONDITIONS

A. Ambient Conditions

1. Equipment Installation Location: A below-grade vault that is subject to flooding.
 - a. Atmospheric condensing conditions are common throughout the year.

1.6 WARRANTY

A. Manufacturer Warranty

1. Provide manufacturer warranty as specified in Section 01 78 33 – Warranties and Bonds with the exception that the warranty period is for two (2) years.

PART 2 PRODUCTS

2.1 EQUIPMENT

A. Manufacturers

1. Manufacturer List
 - a. Flygt by Xylem, Inc.
 - b. Ebara Fluid Handling
 - c. KSB
 - d. Grundfos
 - e. Engineer approved equal
2. Substitution Limitations

- a. The naming of a manufacturer in this Section is not an indication that the manufacturer's standard equipment is acceptable in lieu of the specified component features. Naming is only an indication that the manufacturer may have the capability of engineering and supplying a system as specified.

B. Performance/Design Criteria

1. The pumps shall operate within the Hydraulic Institute standards and pump manufacturer's requirements under the design operating levels indicated for the wet well. The Pump Schedule data below indicates the minimum hydraulic performance requirements for each pump (Design Condition #2), identifying if the pump is to operate within the Preferred Operating Range (POR) or the Allowable Operating Range (AOR) under the design conditions. The POR is defined as 70% to 120% of the flow at the Best Efficiency Point (BEP) for the respective pump. The AOR is defined as 50% to 120% of the flow at the BEP. **If the proposed pump cannot meet the indicated minimum requirements, the pump will not be accepted and the manufacturer shall be required to provide a pump capable of operating within the required range or pay the cost difference for a pump which meets this requirement.**

2. Pump Schedule:

Pump Station	2000 West Place PS		
Number of Units	2		
Designation/Tag Numbers	P-1, P-2		
Minimum Suction Diameter (inches)	3		
Minimum Discharge Diameter (inches)	3		
Liquid Pumped	Municipal Raw Sewage		
Temperature of Liquid Pumped	Ambient		
Suction Condition	Flooded		
Drive Type	Constant Speed		
Maximum Size of Solids (Spherical Diameter) (inches)	3		
Minimum Stable Continuous Flow (gallons/minute)	80		
Design Condition	#1	#2	#3
Pump Capacity (gallons/minute)	240	360	420
Total Dynamic Head (TDH) (feet)	106	78	61
Minimum Pump Efficiency (percent)		61	
Maximum NPSHr (feet)			34
Minimum Required Operating Range		POR	

Pump Station	Centerville Road PS		
Number of Units	2		
Designation/Tag Numbers	P-1, P-2		
Minimum Suction Diameter (inches)	6		

Minimum Discharge Diameter (inches)	3		
Liquid Pumped	Municipal Raw Sewage		
Temperature of Liquid Pumped	Ambient		
Suction Condition	Flooded		
Drive Type	Constant Speed		
Maximum Size of Solids (Spherical Diameter) (inches)	3		
Minimum Stable Continuous Flow (gallons/minute)	130		
Design Condition	#1	#2	#3
Pump Capacity (gallons/minute)	200	400	600
Total Dynamic Head (TDH) (feet)	109	72	32
Minimum Pump Efficiency (percent)		57	
Maximum NPSHr (feet)			26
Minimum Required Operating Range		POR	

Pump Station	Millerbrook PS		
Number of Units	2		
Designation/Tag Numbers	P-1, P-2		
Minimum Suction Diameter (inches)	4		
Minimum Discharge Diameter (inches)	3		
Liquid Pumped	Municipal Raw Sewage		
Temperature of Liquid Pumped	Ambient		
Suction Condition	Flooded		
Drive Type	Constant Speed		
Maximum Size of Solids (Spherical Diameter) (inches)	3		
Minimum Stable Continuous Flow (gallons/minute)	100		
Design Condition	#1	#2	#3
Pump Capacity (gallons/minute)	125	185	250
Total Dynamic Head (TDH) (feet)	23	17	9
Minimum Pump Efficiency (percent)		62	
Maximum NPSHr (feet)			12
Minimum Required Operating Range		POR	

Pump Station	Mink Livsey PS		
Number of Units	2		

Designation/Tag Numbers	P-1, P-2		
Minimum Suction Diameter (inches)	6		
Minimum Discharge Diameter (inches)	4		
Liquid Pumped	Municipal Raw Sewage		
Temperature of Liquid Pumped	Ambient		
Suction Condition	Flooded		
Drive Type	Constant Speed		
Maximum Size of Solids (Spherical Diameter) (inches)	3		
Minimum Stable Continuous Flow (gallons/minute)	150		
Design Condition	#1	#2	#3
Pump Capacity (gallons/minute)	150	325	600
Total Dynamic Head (TDH) (feet)	227	188	131
Minimum Pump Efficiency (percent)		54	
Maximum NPSHr (feet)			26
Minimum Required Operating Range		AOR	

Pump Station	Northbrook #2 PS		
Number of Units	2		
Designation/Tag Numbers	P-1, P-2		
Minimum Suction Diameter (inches)	6		
Minimum Discharge Diameter (inches)	4		
Liquid Pumped	Municipal Raw Sewage		
Temperature of Liquid Pumped	Ambient		
Suction Condition	Flooded		
Drive Type	Constant Speed		
Maximum Size of Solids (Spherical Diameter) (inches)	3		
Minimum Stable Continuous Flow (gallons/minute)	250		
Design Condition	#1	#2	#3
Pump Capacity (gallons/minute)	337	430	600
Total Dynamic Head (TDH) (feet)	128	114	78
Minimum Pump Efficiency (percent)		60	
Maximum NPSHr (feet)			26
Minimum Required Operating Range		POR	

Pump Station	Roselake PS		
Number of Units	2		
Designation/Tag Numbers	P-1, P-2		
Minimum Suction Diameter (inches)	4		
Minimum Discharge Diameter (inches)	3		
Liquid Pumped	Municipal Raw Sewage		
Temperature of Liquid Pumped	Ambient		
Suction Condition	Flooded		
Drive Type	Constant Speed		
Maximum Size of Solids (Spherical Diameter) (inches)	3		
Minimum Stable Continuous Flow (gallons/minute)	130		
Design Condition	#1	#2	#3
Pump Capacity (gallons/minute)	220	385	420
Total Dynamic Head (TDH) (feet)	110	71	62
Minimum Pump Efficiency (percent)		60	
Maximum NPSHr (feet)			34
Minimum Required Operating Range		POR	

Pump Station	Southfork PS		
Number of Units	2		
Designation/Tag Numbers	P-1, P-2		
Minimum Suction Diameter (inches)	4		
Minimum Discharge Diameter (inches)	3		
Liquid Pumped	Municipal Raw Sewage		
Temperature of Liquid Pumped	Ambient		
Suction Condition	Flooded		
Drive Type	Constant Speed		
Maximum Size of Solids (Spherical Diameter) (inches)	3		
Minimum Stable Continuous Flow (gallons/minute)	130		
Design Condition	#1	#2	#3
Pump Capacity (gallons/minute)	130	160	400
Total Dynamic Head (TDH) (feet)	121	115	61
Minimum Pump Efficiency (percent)		48	

Maximum NPSHr (feet)			31
Minimum Required Operating Range		AOR	

C. Operation

1. Operators

- a. Operate each pump using the pump HAND-OFF-AUTO (H-O-A) selector switch at the local control panel.

2. Controls

- a. Pump H-O-A Selector Switch in HAND Position: Pump continuously operates unless automatically stopped by the machine protection devices (high temperature, seal failure, etc.).
- b. Pump H-O-A Selector Switch in OFF Position: Pump does not operate.
- c. Pump H-O-A Selector Switch in AUTO Position: Pump starts when a high wastewater level is detected by the level control system mounted upstream of the pump(s). In general, the level control system sequences pump(s) ON as the wastewater level increases in the wet well and turns the operating pump(s) OFF as the wastewater level decreases below the control elevations.
 - 1) As the wastewater level increases in the wet well, the level control system operates pumps in accordance with the following setpoint elevations, listed from lowest to highest as the wastewater level decreases in the wet well:
 - a) “Low Level”: No pumps are permitted to operate unless the wastewater level exceeds this elevation.
 - b) “Start Lead Pump”: The control system starts the pump that is currently designated as the lead pump in the alternation sequence.
 - c) “Start Lag Pump”: The control system starts the pump that is designated as the lag pump in the alternation sequence.
 - d) “Start Next Lag Pump”: If more than two service pumps are installed, the control system starts the pump that is designated as the next lag pump in the alternation sequence. This process continues until all service pumps are operating.
 - e) “High Level”: The control system activates the alarm for high wet well level, and all operating pumps continue to run.
 - f) “High High Level”: The control system activates the alarm for high high wet well level, and all operating pumps continue to run.
 - 2) As the wastewater level decreases in the wet well when pump(s) are operating, the control system sequences the pump(s) OFF, one at a time, until all pumps are stopped.
 - 3) When the wastewater level decreases to the “Low Level” elevation in the wet well, the pump station control system automatically alternates the lead pump and lag pump(s) designations.

3. Operation Sequences

- a. Motor High Temperature
 - 1) Disables the pump motor to prevent thermal damage to the motor.
 - 2) Activates the Motor HIGH TEMPERATURE light and common trouble alarm.

- 3) After temperature switch resets, pump automatically resumes operation in the current mode (HAND or AUTO).
- b. Motor Seal Failure (Moisture Intrusion)
 - 1) Pump continues to run in the current mode of operation (HAND or AUTO).
 - 2) Activates the Seal FAIL light and common trouble alarm.
- c. Power Failure
 - 1) When Pump is Running: Operation resumes when power is restored.
 - 2) When Pump is in a Fail Condition: Fail indicator reactivates when power is restored.
- d. Provide logic to maintain all alarm and fail condition indication and contact outputs, including the common FAIL contact output, until the Owner manually presses the RESET pushbutton at the local control panel to reset the alarm and fail conditions.

D. Materials

1. General

- a. Provide the most efficient pump available at the desired design point as recommended by the manufacturer.
- b. Capable of handling raw, unscreened sewage and wastewater and fully-guaranteed for this use.
- c. Suitable for continuous or intermittent operation.
- d. Bottom suction, centerline discharge construction.
- e. Supplied with a foot-mounted discharge connection elbow and integral sliding rail removal system as designed by the pump manufacturer to match the pumps being furnished.
- f. Protect all non-stainless steel metal surfaces coming in contact with the pumped media, including the impeller and the interior of the casing, with a factory-applied spray coating of pump manufacturer's recommended modified acrylic primer and finish that is guaranteed to protect the pump from the pumped media.

2. Volute Casing

- a. Close-grained cast iron conforming to ASTM A48, Class 30, 35, or 40.
 - 1) Lifting Cover and Stator Housing: Same materials of construction as volute casing.
 - 2) Furnish ductile iron volute casing if recommended by pump manufacturer for specified pressure rating.
- b. A smooth surface devoid of blowholes, pits, burrs, and other casting irregularities.
- c. Single-piece, non-concentric design.
- d. Smooth fluid passages large enough at all points to pass any size solids which can pass through the impeller.
- e. Where standard for the required size pump, provide a cleanout port (hand hole) to allow the removal of any foreign material blocking or impeding pump performance.

3. O-Rings

- a. Machine all pump/motor unit mating surfaces where watertight sealing is required. After machining, fit mating surfaces with round O-rings composed of Viton.
 - b. Fit O-rings so joint sealing is accomplished by metal-to-metal contact between machined surfaces, resulting in controlled compression of the rubber O-rings in two planes and O-ring contact on four sides without the requirement of a specific bolt torque limit.
 - c. Not Acceptable nor Equal O-Ring Types include but are not limited to:
 - 1) Rectangular cross-sectioned rubber or paper gaskets.
 - 2) Gaskets that require specific torque limits to achieve compression.
 - 3) Joint seals that require secondary sealing compounds, elliptical O-rings, grease, or other devices.
4. Impeller
- a. Hard alloy cast iron conforming to ASTM A48, Class 30, 35, or 40.
 - b. Dynamically-balanced, single-vaned (smaller pumps) or multiple-vaned (larger pumps), enclosed or semi-open, non-clog design.
 - 1) Long throughlets without acute turns.
 - c. Capable of handling solids, fibrous materials, heavy sludge, and other matter found in normal wastewater applications.
 - 1) Capable of passing the maximum diameter of spherical solid previously specified at a minimum.
 - d. Mechanically secured/keyed or friction fit to the motor shaft and retained per manufacturer's recommendations utilizing machined stainless steel components.
 - e. Not Acceptable: Adhesive type fits.
5. Casing and Impeller Wear Ring System
- a. Provide efficient sealing between the volute and suction inlet of the impeller.
 - b. Fit each pump with a stainless steel, Buna-N-coated steel or brass ring insert that is drive-fitted to the volute inlet.
6. Pump/Motor Shaft
- a. AISI Type 329 or 400 Series stainless steel.
 - b. Solid and continuous
 - 1) Pump Shaft: Extension of the motor shaft.
 - 2) Not Acceptable: Using couplings to join the pump shaft and motor shaft.
 - c. Capable of safely transmitting the maximum torque developed by the drive unit.
 - d. Designed to provide a rigid support for the impeller and prevent excessive vibration.
 - e. Suitably heat-treated, turned, ground, and polished over its entire length.
7. Shaft Seals
- a. Provide each pump with a tandem mechanical shaft seal system consisting of two totally independent seal assemblies.
 - 1) Provide seals in an oil lubricant reservoir that hydrodynamically lubricates the lapped seal faces at a constant rate during operation.

- a) Design lubricant chamber to prevent overfilling and to provide lubricant expansion capacity.
 - b) Provide drain and inspection plugs, with positive anti-leak seals, that are easily accessible from the outside of the pump.
 - c) Seal Lubricant: FDA-approved and non-toxic.
 - d) Not Acceptable: Relying upon the pumped media to lubricate the seal system
- b. Lower (Primary) Seal Unit
- 1) Located between the pump and the lubricant chamber.
 - 2) Contains one stationary ring and one positively-driven, rotating, industrial duty, corrosion-resistant ring.
 - a) Stationary Seal Ring: Tungsten carbide.
 - b) Rotating Seal Ring: Tungsten carbide or silicon carbide.
 - 3) Capable of resisting the pump shutoff head.
 - 4) Independent of the impeller hub.
- c. Upper (Secondary) Seal Unit
- 1) Located between the lubricant chamber and the motor housing.
 - 2) Contains one stationary ring and one positively-driven, rotating, industrial duty, corrosion-resistant ring.
 - a) Stationary Seal Ring: Ceramic or carbon.
 - b) Rotating Seal Ring: Carbon or Ni-resist.
- d. Provide each seal interface with its own spring system to hold it in contact.
- e. Capable of operating in either a clockwise or counterclockwise direction of rotation without damage or loss of seal.
- f. Capable of running dry without damage.
- g. If Both Seals Fail: Provide a port to immediately direct any fluid that enters the stator housing to the float switch installed in the seal leakage chamber.
 - 1) Not Acceptable: Intruding fluid coming into contact with the lower bearings.
- h. Not Acceptable nor Equal Seal Types
- 1) Shaft seals without positively-driven rotating members.
 - 2) Conventional double mechanical seals containing either a common single or double spring acting between the upper and lower seal faces.
 - 3) Cartridge-type systems.
 - 4) Systems requiring a pressure differential to offset pressure and effect sealing.
 - 5) Seals requiring either maintenance or adjustment.
 - 6) Seals requiring an external source of cooling or lubrication water.
8. Bearings
- a. A minimum of two (2) heavy-duty, sealed bearings on which pump shaft rotates.
 - b. Permanently-lubricated using high temperature grease.
 - c. Designed to carry all radial and axial thrust loads.

- d. A minimum ABMA L10 life of 100,000 hours at all points along the usable portion of the pump curve at maximum pump speed.
9. Motor Cooling Jacket
- a. Provide each pump with an integral, self-supplying cooling system that surrounds/encircles the stator housing and is adequately designed to cool the motor without an external cooling source.
 - b. Provide a stainless steel jacket encircling the stator housing to dissipate motor heat regardless of type of pump installation
 - c. Circulate the cooling liquid through the cooling system using an impeller, integral to the cooling system and driven by the pump shaft.
 - d. Pass cooling liquid about the stator housing in the closed loop system in turbulent flow providing for superior heat transfer.
 - e. Provide one fill port and one drain port integral to the cooling jacket.
 - f. Capable of providing for continuous submerged or completely non-submerged pump operation in liquid or in air having a temperature of up to 40 degrees Celsius (104 degrees Fahrenheit) in accordance with NEMA standards. Restrictions limiting the liquid or ambient temperatures to levels less than 40 degrees Celsius (104 degrees Fahrenheit) are not acceptable.
 - g. Capable of no less than 30 evenly spaced motor starts per hour and able to operate throughout the entire pump performance curve from shut-off through run-out even when the motor is not submerged.
10. Slide Rail Mounting System
- a. Furnish and install a slide rail mounting system for each pump in compliance with the Specifications and as shown on the Drawings.
 - 1) Meets or exceeds UL requirements for operation in a NEC Class I, Division 1, Group D hazardous location.
 - 2) Not Acceptable: Rail systems that require either personnel to enter the wet well or piping disconnection to remove the pump from the wet well for inspection or service.
 - b. Designed to allow for easy removal and reinstallation of pump for inspection or service without needing to remove bolts, nuts, or other fasteners.
 - c. Provide each pump with a foot-mounted discharge connection elbow permanently installed in the wet well along with the discharge piping.
 - 1) Cast iron conforming to ASTM A48, Class 30 or 35.
 - 2) Construct discharge connection elbow with a 125-pound ANSI standard flat-faced flange in accordance with ANSI B16.1 or ANSI B16.5 dimensions.
 - 3) Designed to automatically and firmly connect to pump when pump is lowered into place in a simple downward motion.
 - a) Designed to tightly press against and bear the entire weight of the pump/motor unit to provide positive sealing under all conditions.
 - b) Seal pump to discharge connection using a machined metal-to-metal watertight contact.
 - 4) Provide lower guide rail supports as integral parts of the discharge connection elbow.
 - d. Intermediate and Upper Guide Rail Supports

- 1) AISI Type 316 stainless steel.
- 2) Located as recommended by the pump manufacturer.
- e. Provide a sliding guide bracket as an integral part of the pump unit.
- f. Design the entire sliding rail system to safely withstand all stresses imposed thereon by vibration, torque, shock, and all possible direct and eccentric loads.
 - 1) Not Acceptable: Sliding rail systems, including the discharge elbows, that allow any portion of the pump/motor unit to directly bear on the wet well floor or on a wet well floor-mounted stand.
- g. Guide Rails
 - 1) A minimum of two parallel guide rails that extend from the top of the pump station to the wet well-mounted discharge connection.
 - 2) Standard weight Type 316 stainless steel pipe at a minimum.
 - 3) Adequately and conservatively sized by the pump manufacturer for their intended use.
 - 4) Capable of guiding the entire weight of the pump furnished.
 - 5) Not Acceptable: Guide rails that support any portion of the pump weight.
- h. All Metal-to-Metal Interfaces where Movement Might Occur: Non-sparking.

11. Anchoring and Lifting Components

- a. Provide all anchor bolts, lifting bolts, eye lugs, lifting cable, etc. necessary for complete installation and maintenance of each pump.
 - 1) Type 316 stainless steel.
 - 2) Adequately design components for their intended use(s).

12. Pump Nameplate

- a. In addition to the requirements of Section 01 60 00 – General Equipment Stipulations, include capacity (gallons/minute), rated TDH, speed, and efficiency at the rated design point.

13. Hardware

- a. All Exposed Nuts, Bolts, Washers, and Other Fastening Devices: AISI Type 316 stainless steel.

E. Finishes

1. Primer Materials

- a. Clean and apply manufacturer's recommended primer material to steel and cast iron surfaces of pump in factory that is compatible with the finish material specified in Section 09 91 00 – Painting for submerged wastewater service.

2. Shop Finishing Methods

- a. Perform shop finishing methods on steel and cast iron surfaces of pump in accordance with Section 09 91 00 – Painting for submerged wastewater service.

3. Finish Materials

- a. Prepare and apply finish material to steel and cast iron surfaces of pump in field in accordance with Section 09 91 00 – Painting for submerged wastewater service.
- b. Field touch-up any damaged paint or coatings with compatible paint/coating system in accordance with Section 09 91 00 – Painting.

2.2 ELECTRICAL AND CONTROL REQUIREMENTS

- A. Provide all electrical components, wiring, and control devices necessary for a complete, functional system in accordance with the appropriate Sections of Division 26 – Electrical and Division 40 – Process Integration.
- B. All Manufacturer-Furnished Electrical Appurtenances: Rated for installation in a NEC Class I, Division 1, Group D hazardous location where such classified areas are indicated on the Drawings or specified herein.
- C. Power and Control Cables
 - 1. Provided by the pump manufacturer in the required length based on their review of the Electrical Drawings.
 - a. Provide cables with enough slack to be able to route and secure them out of the way of any equipment in the wet well.
 - 2. Located between the pump and the local disconnect switch, junction box, or control panel terminal block as shown on the Drawings.
 - 3. Provide silver-plated copper cable suitable for submersible pump applications.
 - 4. Provide oil-resistant chloroprene rubber jacket around outside of cable.
 - 5. Size according to NEC and ICEA standards.
 - 6. Mine Safety and Health Administration-approved.
 - 7. Not Allowable: Splicing cables unless specifically indicated on the Drawings.
 - 8. Provide stainless steel strain relief connectors for all cables.
 - 9. Wires for Thermal Switches and Moisture Sensor.
 - a. Option #1: Part of a composite motor cable.
 - b. Option #2: Separate from motor cable.
 - 1) Provide adequate wire length to reach the control panel without splicing.
- D. Cable Entry Water Seal
 - 1. Designed to ensure a watertight and submersible seal without specific torque requirements.
 - 2. Provide either Type 1 or Type 2 cable entry water seal as follows:
 - a. Type 1
 - 1) A single cylindrical elastomer grommet, flanked by stainless steel washers all having a close tolerance fit against the cable outside diameter and the entry inside diameter and compressed by the entry body containing a strain relief function separate from the function of sealing the cable.
 - 2) Designed to bear against a shoulder in the pump top.
 - 3) Use a stator lead sealing gland or terminal board to separate the cable entry junction chamber and the motor.
 - 4) Use an elastomer compression O-ring to seal the motor from the junction chamber containing the terminal board.
 - 5) Connect the cable conductors to the stator leads using threaded, compressed-type binding posts permanently affixed to the terminal board, resulting in a leak-proof connection.

- 6) Equip each pump with a separate terminal board that totally isolates the incoming power supply from the pump motor.
- b. Type 2
- 1) A rubber grommet followed by epoxy.
 - 2) For all power and control lead wires, provide a double seal where the wires enter the top of the motor in such a manner to prevent cable-wicking from occurring.
 - 3) Accomplish the cable-to-motor connection in the field without soldering.
 - 4) Remove a small section of insulation from each conductor to establish a window area of bare wire.
 - a) Wire: Untwisted and surrounded by epoxy potting material.
 - 5) Provide a cable strain relief mechanism as an integral part of the sealing system.
 - 6) Capable of withstanding an external pressure test of 1,200 psi and a cable assembly pull test as required by UL.
 - 7) Terminate power and control leads on a sealed terminal board.
 - a) Provide O-rings to seal the terminal board and its bronze lugs.

E. Electrical Requirements

Motors	
Rating	
2000 West Place PS	460V, 3 phase, 60 Hz
Centerville Road PS	230V, 3 phase, 60 Hz
Millerbrook PS	230V, 3 phase, 60 Hz
Mink Livsey PS	460V, 3 phase, 60 Hz
Northbrook #2 PS	460V, 3 phase, 60 Hz
Roselake PS	230V, 3 phase, 60 Hz
Southfork PS	460V, 3 phase, 60 Hz
Maximum Horsepower (hp)	
2000 West Place PS	20
Centerville Road PS	20
Millerbrook PS	5
Mink Livsey PS	35
Northbrook #2 PS	35
Roselake PS	15
Southfork PS	15
Maximum Speed (revolutions/minute)	3,500
Insulation	Class F
Explosion Proof	Yes
Inverter Duty	No
Service Factor	1.15
Resistance Temperature Detectors	No
Cooling Jacket	No
Control Panel	
NEMA Rating	4X
Materials of Construction	Type 316 Stainless Steel With white baked enamel finish

F. Motor

1. Provide each pump with a motor in conformance with the most recent versions of applicable NEMA, IEEE, and ANSI standards for submersible service.
 - a. NEMA Design B.
2. Squirrel-cage induction-type.
3. Housed in an air-filled, watertight enclosure specifically designed for submersible pump applications.
 - a. Housing: Close-grained cast iron conforming to ASTM A48, Class 30, 35, or 40.
4. Provided with moisture-resistant stator winding and stator leads.
5. Guaranteed for continuous operation without damage while non-submerged and pumping media of up to 40 degrees Celsius (104 degrees Fahrenheit) with an even 80 degrees Celsius (176 degrees Fahrenheit) temperature rise.
6. Capable of continuous submergence without loss of watertight integrity to a depth of 65 feet.
7. Motors Greater than 25 hp: Capable of sustaining a minimum of fifteen (15) starts per hour without overheating.
8. Rotor Bars and Short Circuit Rings: Cast aluminum.
9. Provided with pre-lubricated radial and thrust bearings which are designed to carry the entire load which may be imposed upon the motor under all operating conditions.
10. Manufactured by pump manufacturer.
11. Provide adequate motor horsepower so that the pump is non-overloading throughout the entire pump performance curve from shut-off through run-out.
12. Motor Stator-Embedded Temperature Switches
 - a. Equip each motor with two (2) or three (3) normally-closed thermal switches in series, one per phase, that are embedded in the stator end coils to monitor the temperature of each phase winding.
 - b. Upon High Temperature: Switches open, activate an alarm, and stop the motor.
 - c. Use switches in conjunction with and supplemental to external motor overload protection.
 - d. Connect switches to control panel.
13. Seal off junction chamber from stator housing for connection of power and control cables.
 - a. Not Acceptable: Using wire nuts or crimping-type connectors.
14. Not Acceptable: Using bolts, pins, or other fastening devices that require penetration of the stator housing.

G. Motor Protection Devices

1. Provide moisture detector probes in the oil seal chamber as required to validate warranty. Provide manufacturer's moisture detection relay compatible with the probes. Install relay in the Pump Control Panel.

2.3 ACCESSORIES

A. Control Panel

1. Provide a single pump manufacturer's local control panel incorporating all pumps furnished in accordance with the requirements of Section 40 95 16 – Instrument and Control Panels and the standard wiring and ladder diagrams provided in the Specifications.
- B. Cable Grips
1. Provide cable grips for the submersible power and control cables for the pump motor.
 2. Stainless steel wire braid sleeves with attachment loops or tails that connect to the cable holders on the underside of the access hatch frame.
 3. Hubbell Wiring Device-Kellems or equal.
- C. Spare Parts
1. Furnish the following spare parts for each series of pumps in accordance with Section 01 60 00 – General Equipment Stipulations.
 - a. One (1) casing wear ring (if applicable).
 - b. One (1) impeller wear ring (if applicable).
 - c. Two (2) complete sets of gaskets and O-ring seals.
 - d. One (1) motor starter with overload block.
 - e. Five (5) spare fuses for each type and rating provided.
 - f. Five (5) spare lamps for each type provided.
 - g. Five (5) spare relays and relay sockets for each type provided.
 2. Properly pack in containers suitable for long-term storage.
 3. Attach labels that clearly designate the contents and the piece(s) of equipment for which they are intended.
 4. Store all materials in a location as directed by the Owner.
 5. Provide spare parts of the same type and quality as the original components in the furnished pump package(s).
- D. Special Tools and Supplies
1. Furnish all special tools necessary to operate, disassemble, service, repair, and adjust the pump.
 2. Furnish a one-year supply of all lubricating oils and greases as recommended by the manufacturer.

2.4 SOURCE QUALITY CONTROL

A. Tests and Inspections

1. Perform shop testing in accordance with Section 01 60 00 – General Equipment Stipulations, all applicable methods and standards of the American National Standard for Centrifugal Pump Tests by the Hydraulic Institute, and the following additional requirements:
 - a. Check impeller, motor rating, and electrical connections.
 - b. Conduct a motor and cable insulation test for moisture content or defective insulation.
 - c. Prior to submergence, run pump dry to establish correct rotation and mechanical integrity.
 - d. Run pump for 30 minutes submerged a minimum of six feet under water.

- e. After the 30-minute submergence test, perform the insulation test again.
- f. After the second insulation test, perform a certification test as follows:
 - 1) Perform on each of the actual assembled pumps to be furnished.
 - 2) Test pumps in the manufacturer's facility in accordance with the latest test code of the Hydraulic Institute Level A to determine head vs. capacity and power draw required.
 - 3) Test Range: Shut-off to a minimum of 20 percent beyond the specified design performance capacity
 - 4) Tolerances: As specified by the Hydraulic Institute Standards with the following exceptions:
 - a) At TDH for Each Design Condition: +10 percent of specified pump capacity for that Design Condition
 - b) At Pump Capacity for Each Design Condition: +5 percent of specified TDH for that Design Condition
 - c) Not Acceptable: Negative tolerances with respect to capacity, TDH, or efficiency at the Design Conditions
 - 5) Generate a pump curve that shows actual flow, head, brake hp, and hydraulic efficiency for each pump furnished.
 - 6) Submit pump curves, each certified by a registered Professional Engineer, to the Owner.

PART 3 EXECUTION

3.1 INSTALLATION

A. Installation of the pumps and control panels will be performed by others.

B. Special Techniques

- 1. Install the pump and accessories in accordance with the approved Shop Drawings and the manufacturer's printed instructions and recommendations.
- 2. Install guide rails plumb and parallel.
- 3. Prior to being cast into concrete, coat aluminum frames of access hatches in contact with concrete with bituminous paint.
- 4. Install cable grips on the submersible cables and attach them to a stainless steel eyebolt installed in the vertical face of the concrete under the access hatch. Loop the submersible cable from the grips, under the roof, and up through the conduit to the local control panel.

3.2 FIELD QUALITY CONTROL

A. Field Tests and Inspections

- 1. Perform field testing in accordance with Section 01 60 00 – General Equipment Stipulations and the following additional requirements:
 - a. Removal and Reinstallation Test
 - 1) Perform the removal and reinstallation test three (3) times for each pump provided.

- 2) Completely remove the pump from the discharge elbow and through the access hatch above.
 - a) Ensure adequate clearance and alignment of access hatch.
 - b) Ensure adequate installation and alignment of slide rail mounting system.
 - 3) Reinstall the pump through the access hatch and onto the discharge elbow.
 - 4) Ensure proper seating of the pump on the discharge elbow.
- b. Final Acceptance Test
- 1) Demonstrate pumps are properly installed and are in proper alignment.
 - 2) Demonstrate the pumps operate without overheating or overloading of any parts and without objectionable vibration.
 - a) Vibration: Within the limits of the Hydraulic Institute Standards or the pump manufacturer's limits, if more stringent.
 - 3) Demonstrate the pumps meet the specified Design Conditions.
 - a) Check each pump at maximum speed for a minimum of four (4) points on the pump curve for capacity, TDH, and amperage.
 - (1) Not Acceptable: Exceeding the rated current on the motor nameplate at any point.
 - (2) Motors Rated Less than 5 hp: Only test pump for overcurrent when overheating or other malfunction is evident during general testing.
- c. Furnish all labor, materials, and test apparatus necessary for conducting the field tests at no additional cost to the Owner.

B. Manufacturer Services

1. Furnish the field services of a qualified, trained, and competent manufacturer's technical representative who has knowledge of the proper installation, operation, and maintenance of the pumps in accordance with Section 01 43 33 – Manufacturer's Services. Include the following site visits for each series of pumps:

Service	Number of Trips	Number of Days/Trip
Installation and Testing	1	1
Startup and Training	1	1

2. Manufacturer's Technical Representative's Minimum Responsibilities
 - a. Inspect the completed installation of each pump for conformance with manufacturer's recommended installation requirements. At a minimum, include the following:
 - 1) Check seal chamber oil level and lubrication of seals.
 - 2) Check proper rotation.
 - 3) Check power supply voltage.
 - 4) Megger for insulation breaks or moisture.
 - 5) Measure motor no-load current.
 - 6) Manually trip sensors and check complete cycle of control operation.
 - b. Supervise field test of each pump.
 - c. Supervise initial startup and operation of each pump.

- d. Instruct Owner's personnel in proper operation and maintenance of pump.
- e. Prepare and certify field inspection report.

3.3 ADJUSTING

- A. After installation, align and adjust the pump and accessories as required for proper operation and proper alignment.

END OF SECTION

APPENDIX A

SAMPLE PUMP STATION CONTROL PANEL DRAWINGS

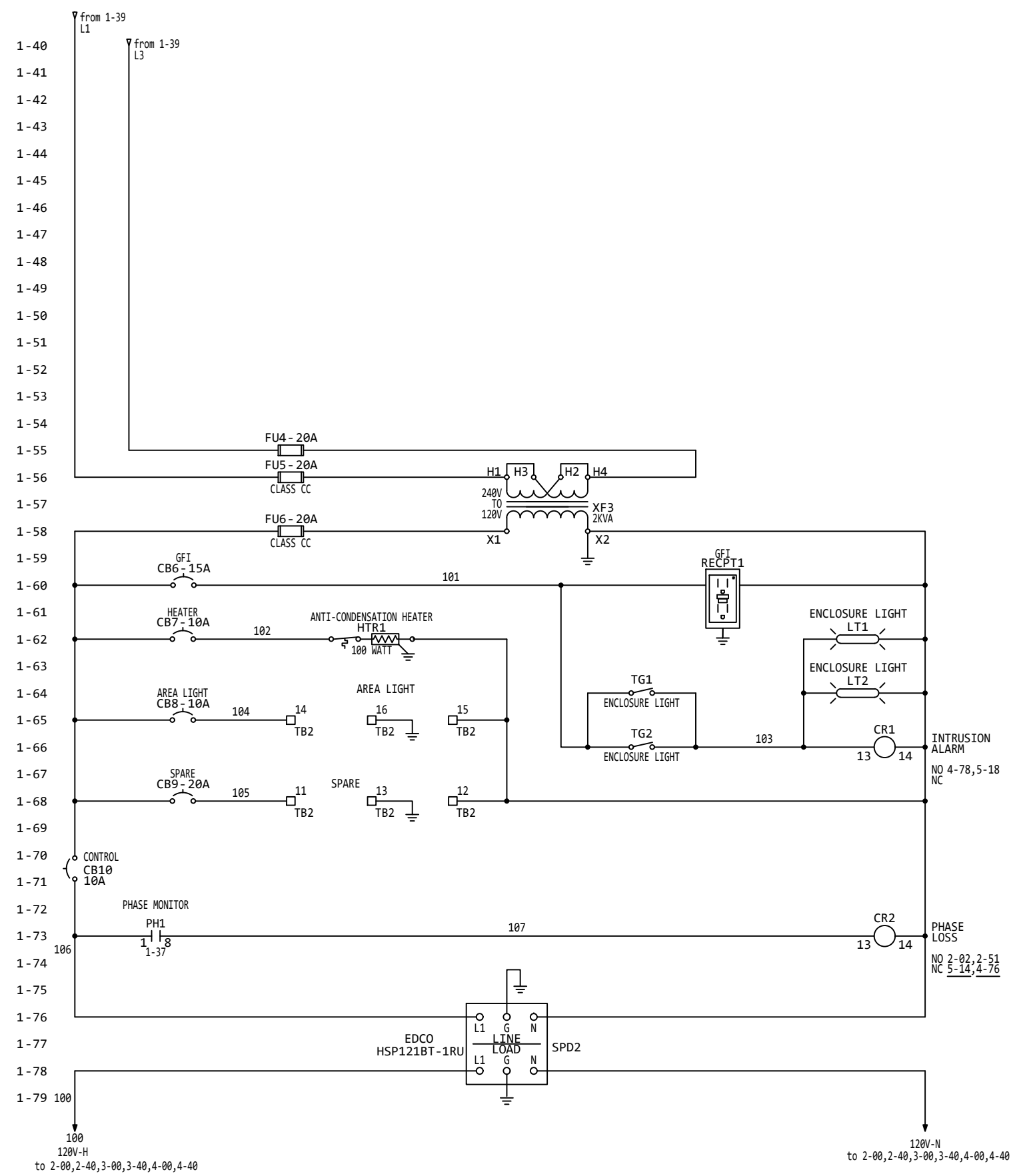
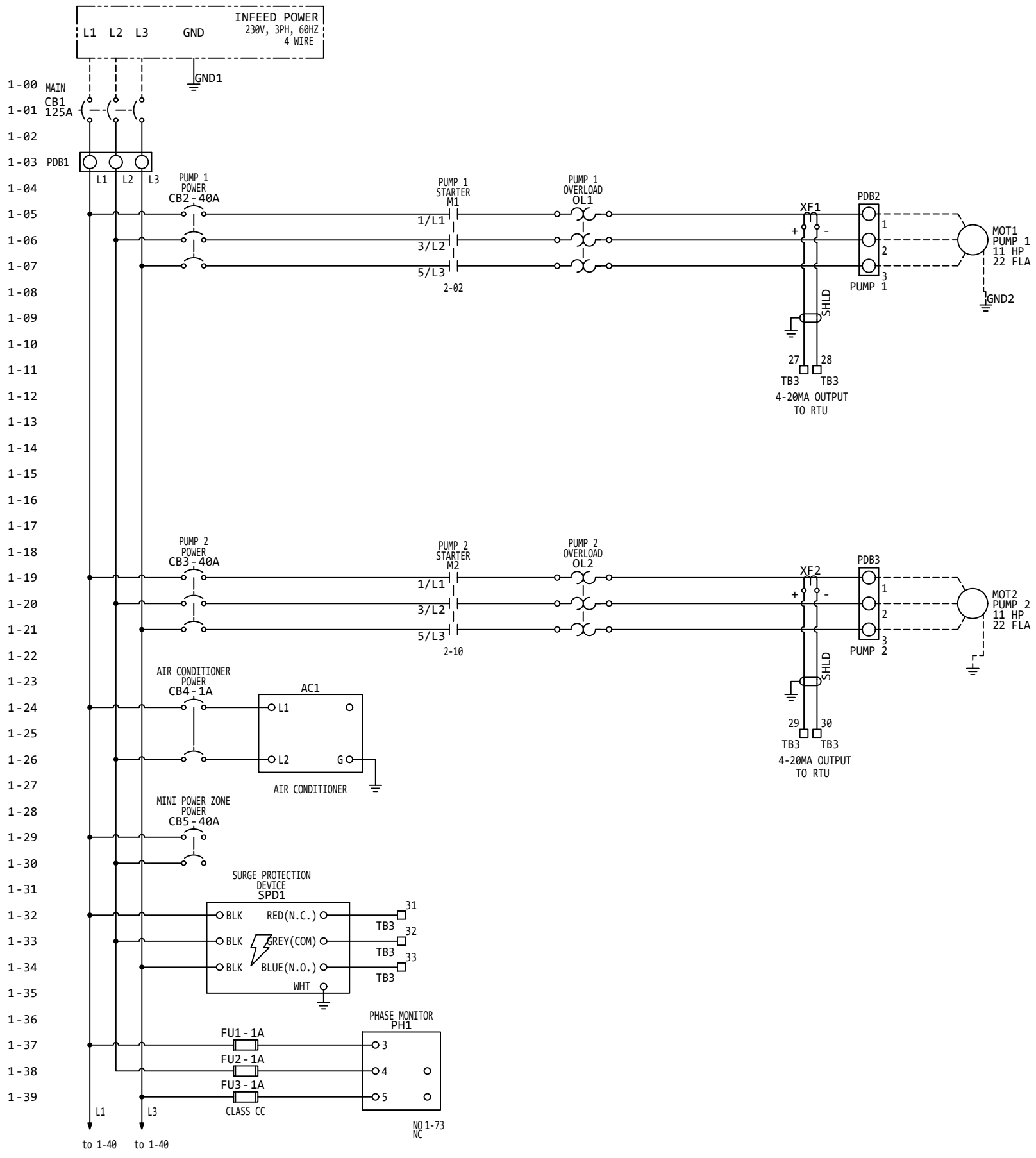

THIS DRAWING CONTAINS PROPRIETARY INFORMATION WHICH MUST NOT BE DUPLICATED, USED, OR DISCLOSED IN WHOLE OR IN PART WITHOUT PRIOR WRITTEN CONSENT.

SHEET NUMBER
1 OF 7

NO.	REVISION HISTORY	DATE	BY
B	CHANGES PER COMMENTS	7/30/21	RDG
A	SUBMITTAL	4/22/21	RDG



GWINNETT CO, GA
RIVERCLIFF PLACE PS

DRAWN BY
RDG

DATE
4/22/2021

PANEL REQUIREMENTS	
SYM.	
VOLTAGE	230 V
PHASE	3
FREQUENCY	60 HZ
SCCR	10kA RMS SYM
TOTAL FLA	76 A
TYPE	4X

LARGEST MOTOR POWER REQUIREMENTS	
HP	11 HP
FLA	22 A

PROJECT NUMBER
5007010A

X:\Projects\5007010A\5007010A-PS\DRAWINGS - XYLEM - GWINNETT CO GA - TANGLEWOOD PS\DRAWINGS AT54815004369AT548-01.dwg

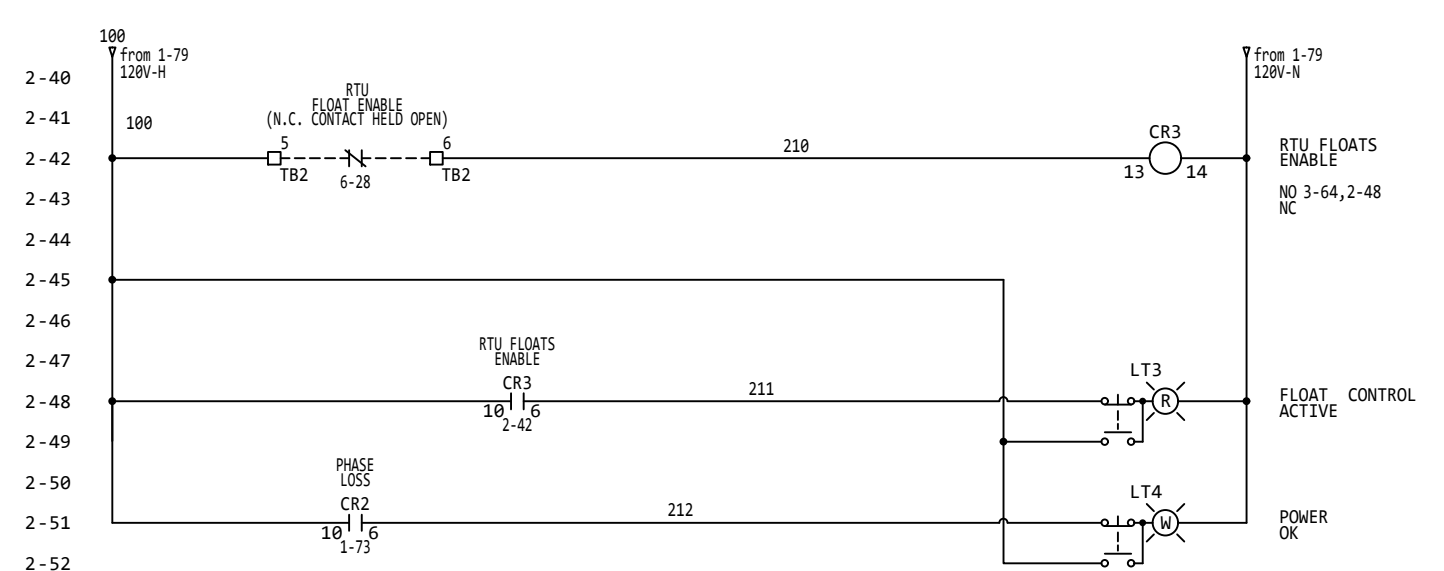
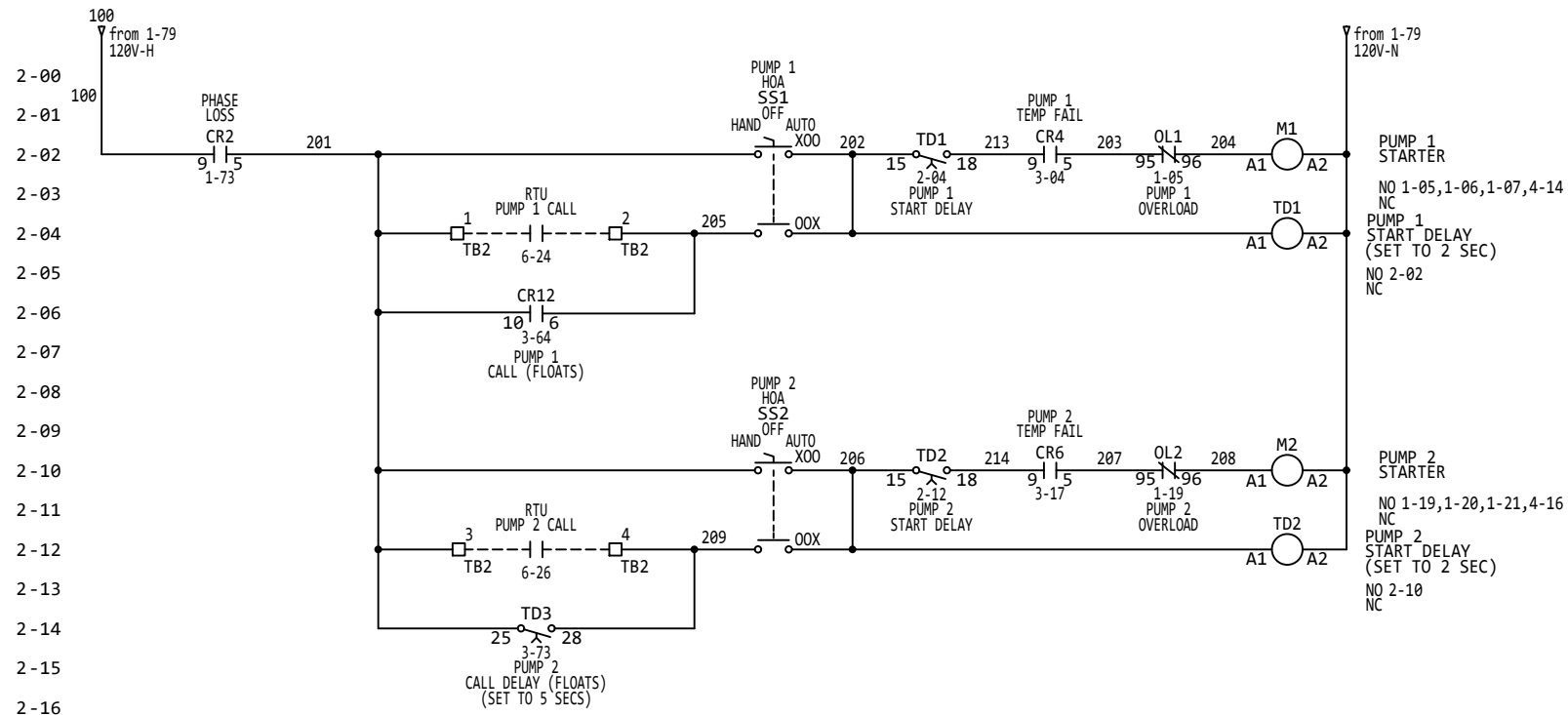

2-00
 2-01
 2-02
 2-03
 2-04
 2-05
 2-06
 2-07
 2-08
 2-09
 2-10
 2-11
 2-12
 2-13
 2-14
 2-15
 2-16
 2-17
 2-18
 2-19
 2-20
 2-21
 2-22
 2-23
 2-24
 2-25
 2-26
 2-27
 2-28
 2-29
 2-30
 2-31
 2-32
 2-33
 2-34
 2-35
 2-36
 2-37
 2-38
 2-39

2-40
 2-41
 2-42
 2-43
 2-44
 2-45
 2-46
 2-47
 2-48
 2-49
 2-50
 2-51
 2-52
 2-53
 2-54
 2-55
 2-56
 2-57
 2-58
 2-59
 2-60
 2-61
 2-62
 2-63
 2-64
 2-65
 2-66
 2-67
 2-68
 2-69
 2-70
 2-71
 2-72
 2-73
 2-74
 2-75
 2-76
 2-77
 2-78
 2-79

THIS DRAWING CONTAINS PROPRIETARY INFORMATION WHICH MUST NOT BE DUPLICATED, USED, OR DISCLOSED IN WHOLE OR IN PART WITHOUT PRIOR WRITTEN CONSENT.

NO.	REVISION HISTORY	DATE	BY
B	CHANGES PER COMMENTS	7/30/21	RDG
A	SUBMITTAL	4/22/21	RDG

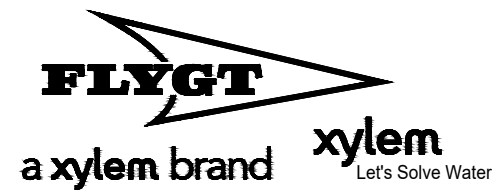

GWINNETT CO, GA
 RIVERCLIFF PLACE PS
 DRAWN BY RDG
 DATE 4/22/2021

PANEL REQUIREMENTS	
SYM.	
VOLTAGE	230 V
PHASE	3
FREQUENCY	60 HZ
SCCR	10kA RMS SYM
TOTAL FLA	76 A
TYPE	4X

LARGEST MOTOR POWER REQUIREMENTS	
HP	11 HP
FLA	22 A
PROJECT NUMBER	
5007010A	

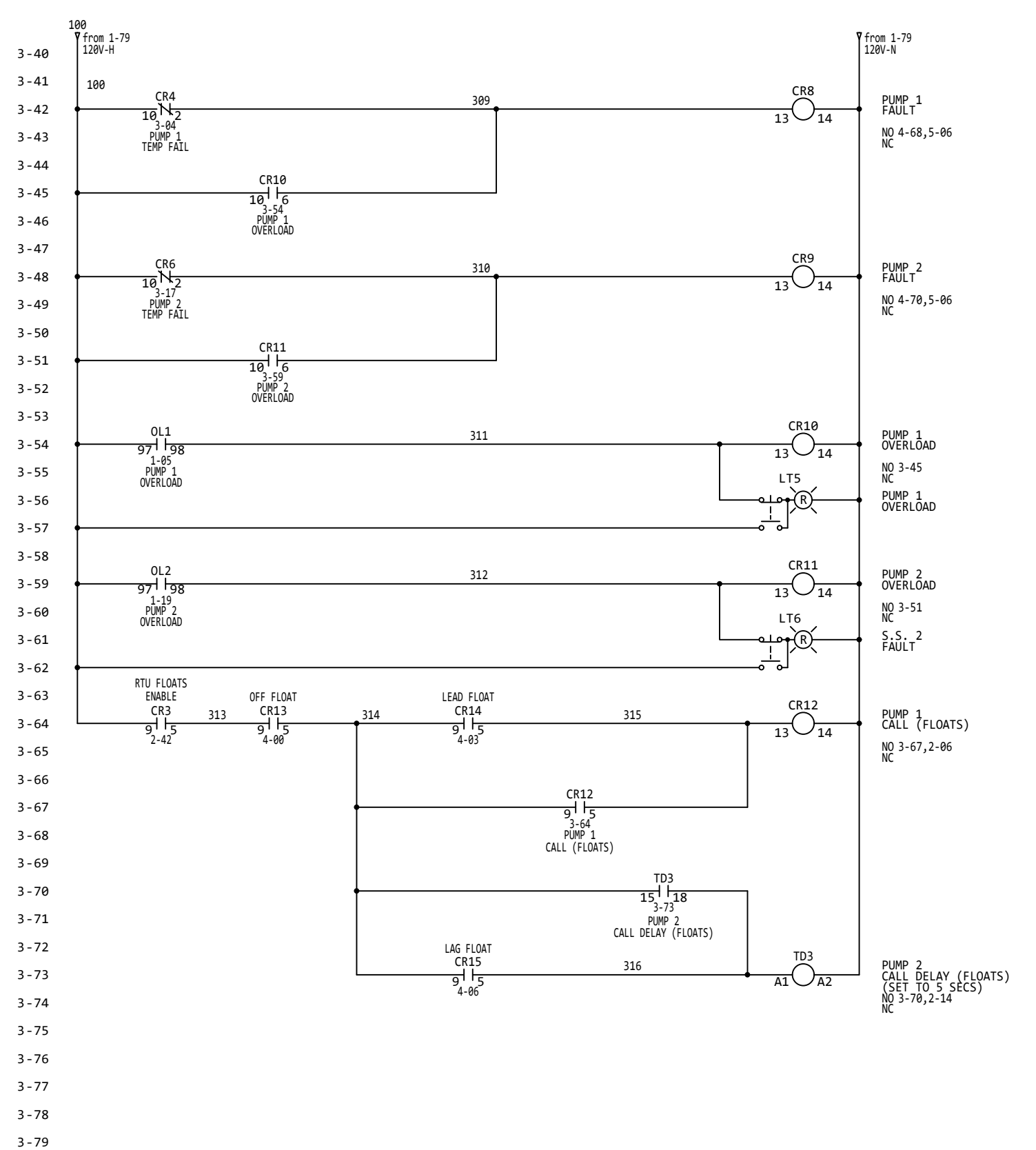
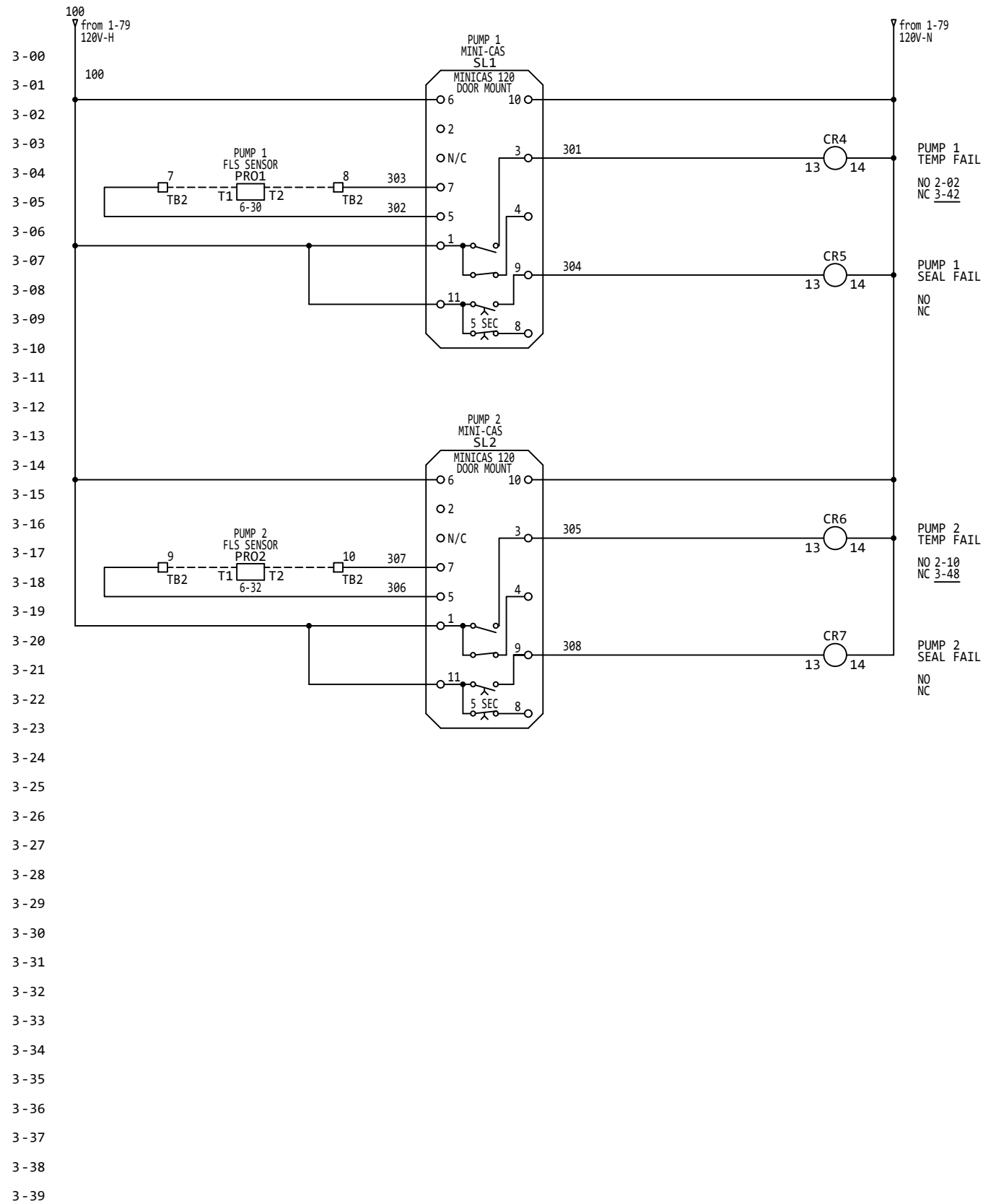

THIS DRAWING CONTAINS PROPRIETARY INFORMATION WHICH MUST NOT BE DUPLICATED, USED, OR DISCLOSED IN WHOLE OR IN PART WITHOUT PRIOR WRITTEN CONSENT.

NO.	REVISION HISTORY	DATE	BY
B	CHANGES PER COMMENTS	7/30/21	RDG
A	SUBMITTAL	4/22/21	RDG

SHEET NUMBER
3 OF 7



GWINNETT CO, GA
RIVERCLIFF PLACE PS

DRAWN BY RDG DATE 4/22/2021

PANEL REQUIREMENTS	
SYM.	
VOLTAGE	230 V
PHASE	3
FREQUENCY	60 HZ
SCCR	10kA RMS SYM
TOTAL FLA	76 A
TYPE	4X

LARGEST MOTOR POWER REQUIREMENTS	
HP	11 HP
FLA	22 A

PROJECT NUMBER
5007010A

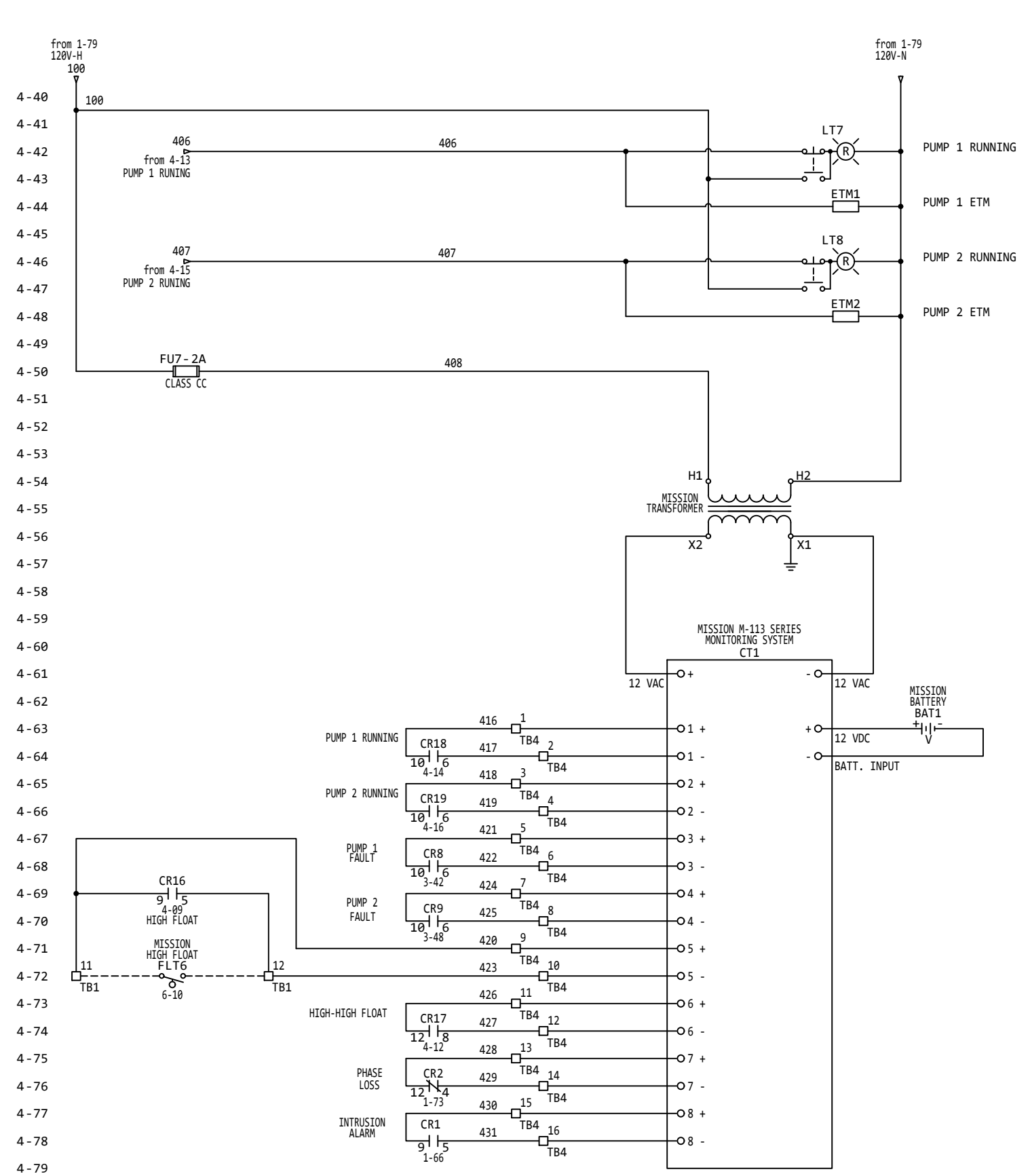
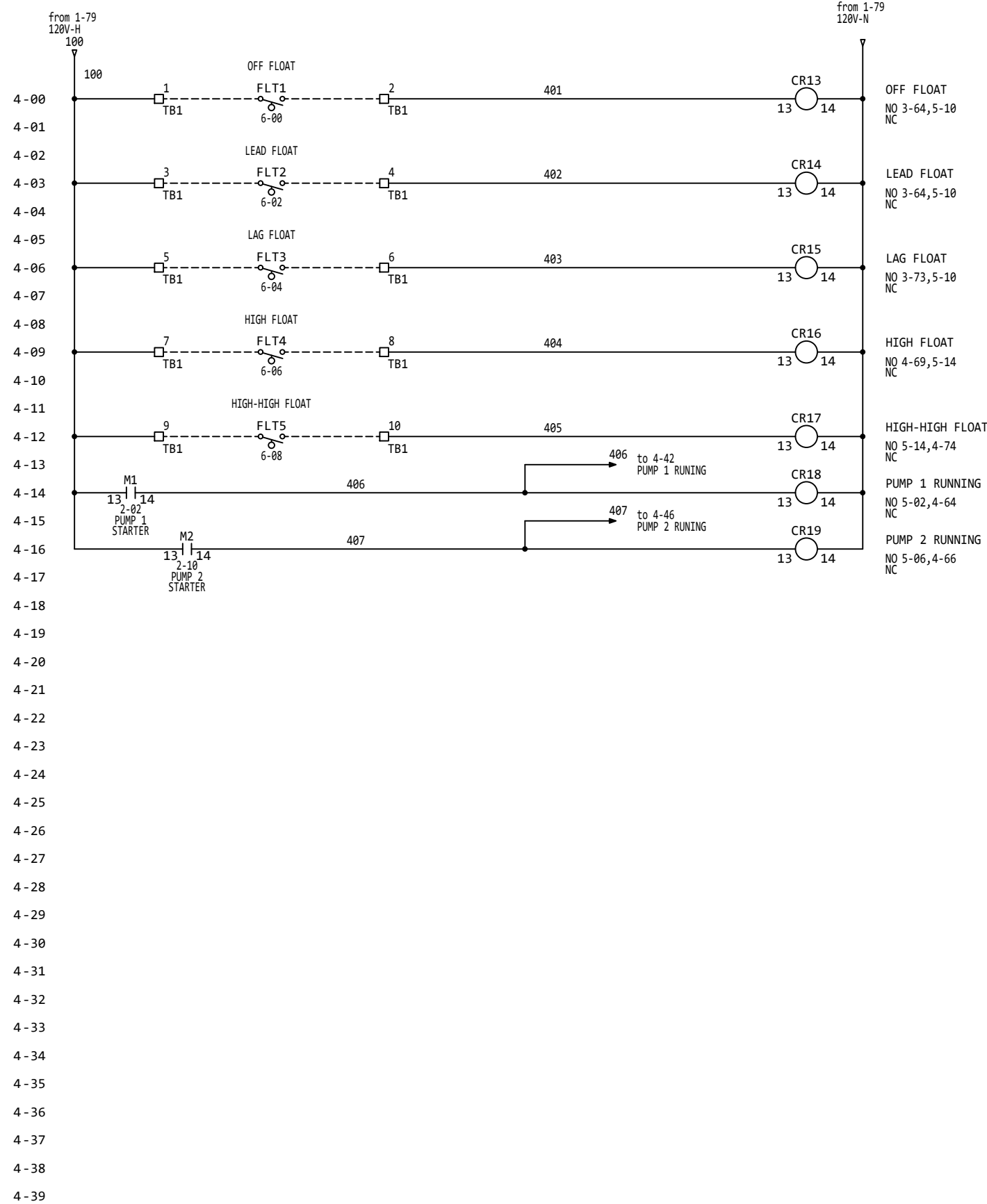

THIS DRAWING CONTAINS PROPRIETARY INFORMATION WHICH MUST NOT BE DUPLICATED, USED, OR DISCLOSED IN WHOLE OR IN PART WITHOUT PRIOR WRITTEN CONSENT.

SHEET NUMBER	NO.	CHANGES PER COMMENTS	DATE	BY
4 OF 7	B	CHANGES PER COMMENTS	7/30/21	RDG
	A	SUBMITTAL	4/22/21	RDG
	NO.	REVISION HISTORY	DATE	BY



GWINNETT CO, GA
RIVERCLIFF PLACE PS

DRAWN BY RDG DATE 4/22/2021

PANEL REQUIREMENTS	
SYM.	
VOLTAGE	230 V
PHASE	3
FREQUENCY	60 HZ
SCCR	10kA RMS SYM
TOTAL FLA	76 A
TYPE	4X

LARGEST MOTOR POWER REQUIREMENTS	
HP	11 HP
FLA	22 A
PROJECT NUMBER	
5007010A	

5-00
5-01
5-02
5-03
5-04
5-05
5-06
5-07
5-08
5-09
5-10
5-11
5-12
5-13
5-14
5-15
5-16
5-17
5-18
5-19
5-20
5-21
5-22
5-23
5-24
5-25
5-26
5-27
5-28
5-29
5-30
5-31
5-32
5-33
5-34
5-35
5-36
5-37
5-38
5-39

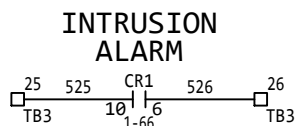
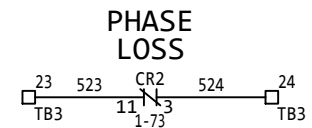
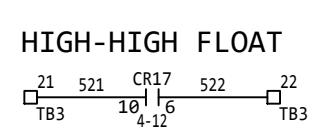
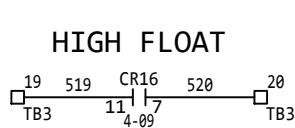
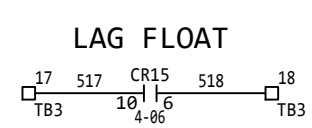
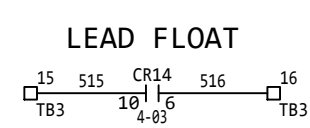
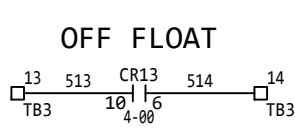
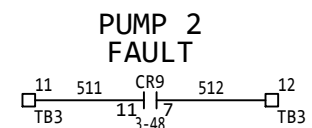
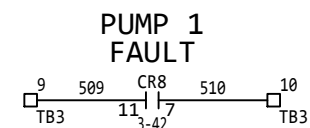
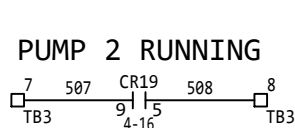
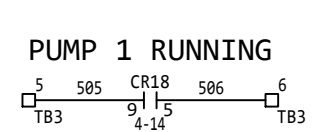
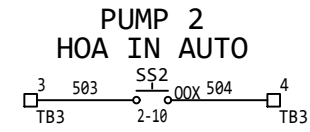
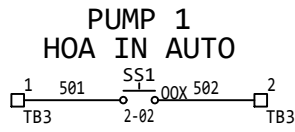

FUSE CHART						
TAG1	RATIN G1	DESC1	MFG	CAT	DESC2	DESC3
FU1	1A	CLASS CC	BUSSM ANN	KTK-R- 1		
FU2	1A		BUSSM ANN	KTK-R- 1		
FU3	1A		BUSSM ANN	KTK-R- 1		
FU4	20A	CLASS CC	BUSSM ANN	FNQ-R- 20		
FU5	20A	CLASS CC	BUSSM ANN	FNQ-R- 20		
FU6	20A	CLASS CC	BUSSM ANN	FNQ-R- 20		
FU7	2A	CLASS CC	BUSSM ANN	FNQ-R- 2		

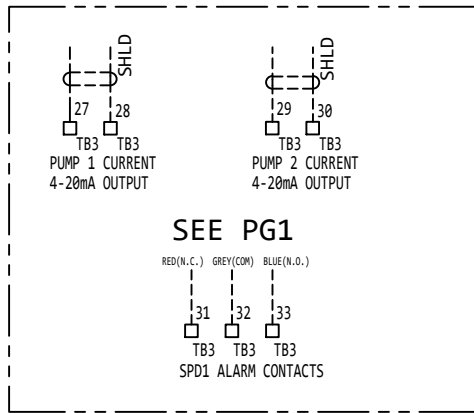

THIS DRAWING CONTAINS PROPRIETARY INFORMATION WHICH MUST NOT BE DUPLICATED, USED, OR DISCLOSED IN WHOLE OR IN PART WITHOUT PRIOR WRITTEN CONSENT.

SHEET NUMBER	B	CHANGES PER COMMENTS	7/30/21	RDG
5 OF 7	A	SUBMITTAL	4/22/21	RDG
NO.		REVISION HISTORY	DATE	BY

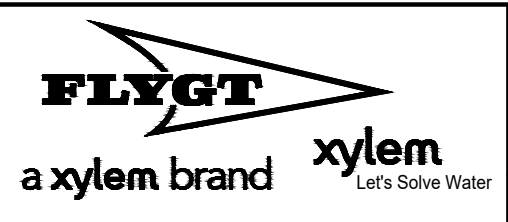

GWINNETT CO, GA
RIVERCLIFF PLACE PS

DRAWN BY RDG
DATE 4/22/2021

PANEL REQUIREMENTS	
SYM.	
VOLTAGE	230 V
PHASE	3
FREQUENCY	60 HZ
SCCR	10kA RMS SYM
TOTAL FLA	76 A
TYPE	4X

LARGEST MOTOR POWER REQUIREMENTS	
HP	11 HP
FLA	22 A
PROJECT NUMBER	
5007010A	

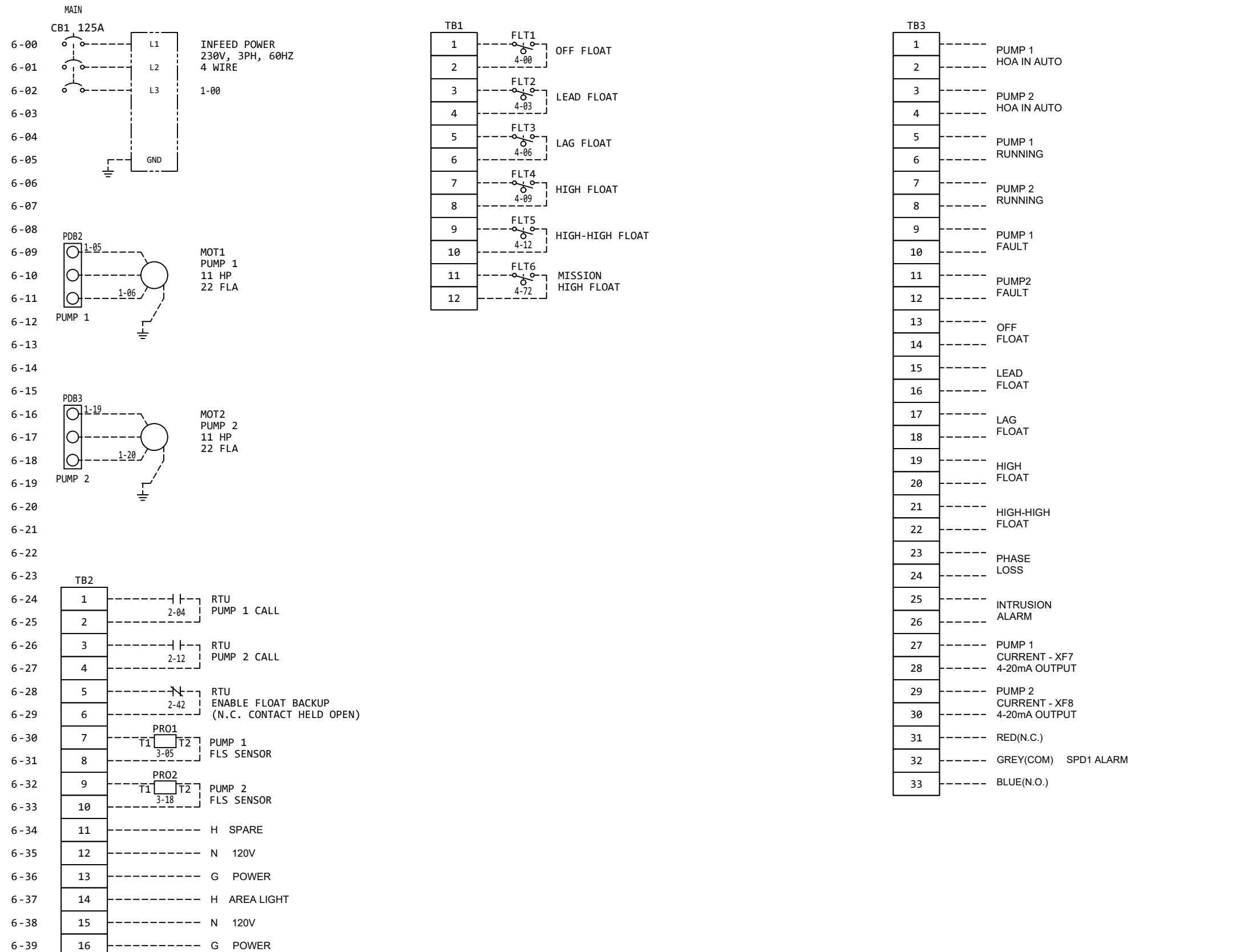

FIELD CONNECTIONS

- NOTES:**
1. FIELD WIRING IS SHOWN -----
 2. TEMPERATURE RATING OF FIELD INSTALLED CONDUCTORS LESS THAN 100 AMPS MUST BE RATED 60DEG C OR ABOVE. FIELD INSTALLED CONDUCTORS GREATER THAN OR EQUAL TO 100 AMPS MUST BE RATED 75 DEG C OR ABOVE.
 3. FIELD WIRING WILL ACCEPT COPPER CONDUCTORS ONLY.
 4. FOR FIELD WIRING REFER TO COMPONENT, OR TORQUE RATING DATASHEET.
 5. MAIN SERVICE DISCONNECT PROVIDED BY OTHERS.

THIS DRAWING CONTAINS PROPRIETARY INFORMATION WHICH MUST NOT BE DUPLICATED, USED, OR DISCLOSED IN WHOLE OR IN PART WITHOUT PRIOR WRITTEN CONSENT.

SHEET NUMBER
6 OF 7

NO.	REVISION HISTORY	DATE	BY
B	CHANGES PER COMMENTS	7/30/21	RDG
A	SUBMITTAL	4/22/21	RDG



GWINNETT CO, GA
 RIVERCLIFF PLACE PS

DRAWN BY
 RDG

DATE
 4/22/2021

PANEL REQUIREMENTS

SYM.	
VOLTAGE	230 V
PHASE	3
FREQUENCY	60 HZ
SCCR	10kA RMS SYM
TOTAL FLA	76 A
TYPE	4X

LARGEST MOTOR POWER REQUIREMENTS

HP	11 HP
FLA	22 A

PROJECT NUMBER
5007010A

SAGINAW, SCE-72EL8218SS6LPPLW, 316 STAINLESS STEEL ENCLOSURE W/12" LEG KIT, WHITE 72"H X 82"W X 18"D

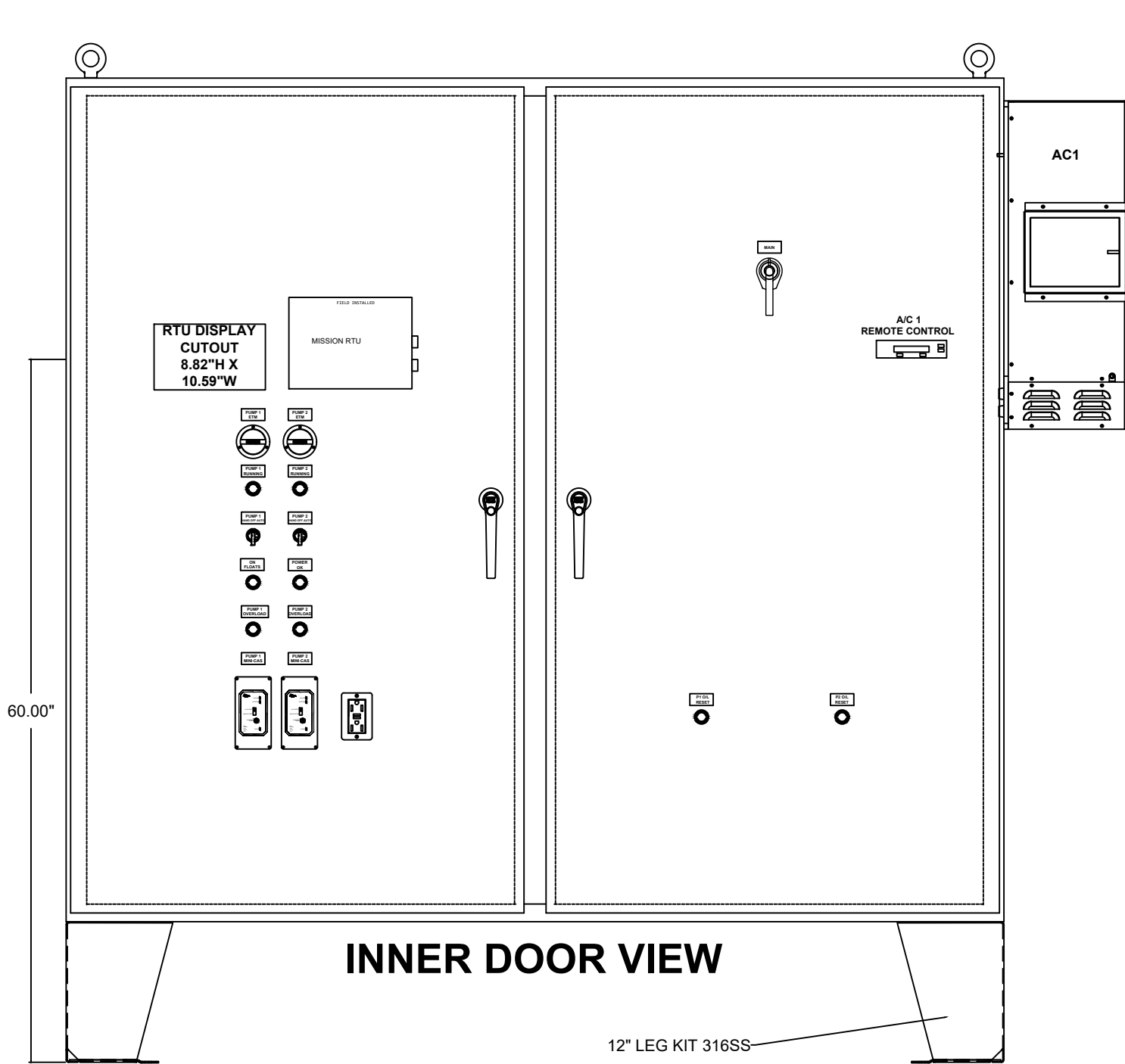

INNER DOOR VIEW

12" LEG KIT 316SS

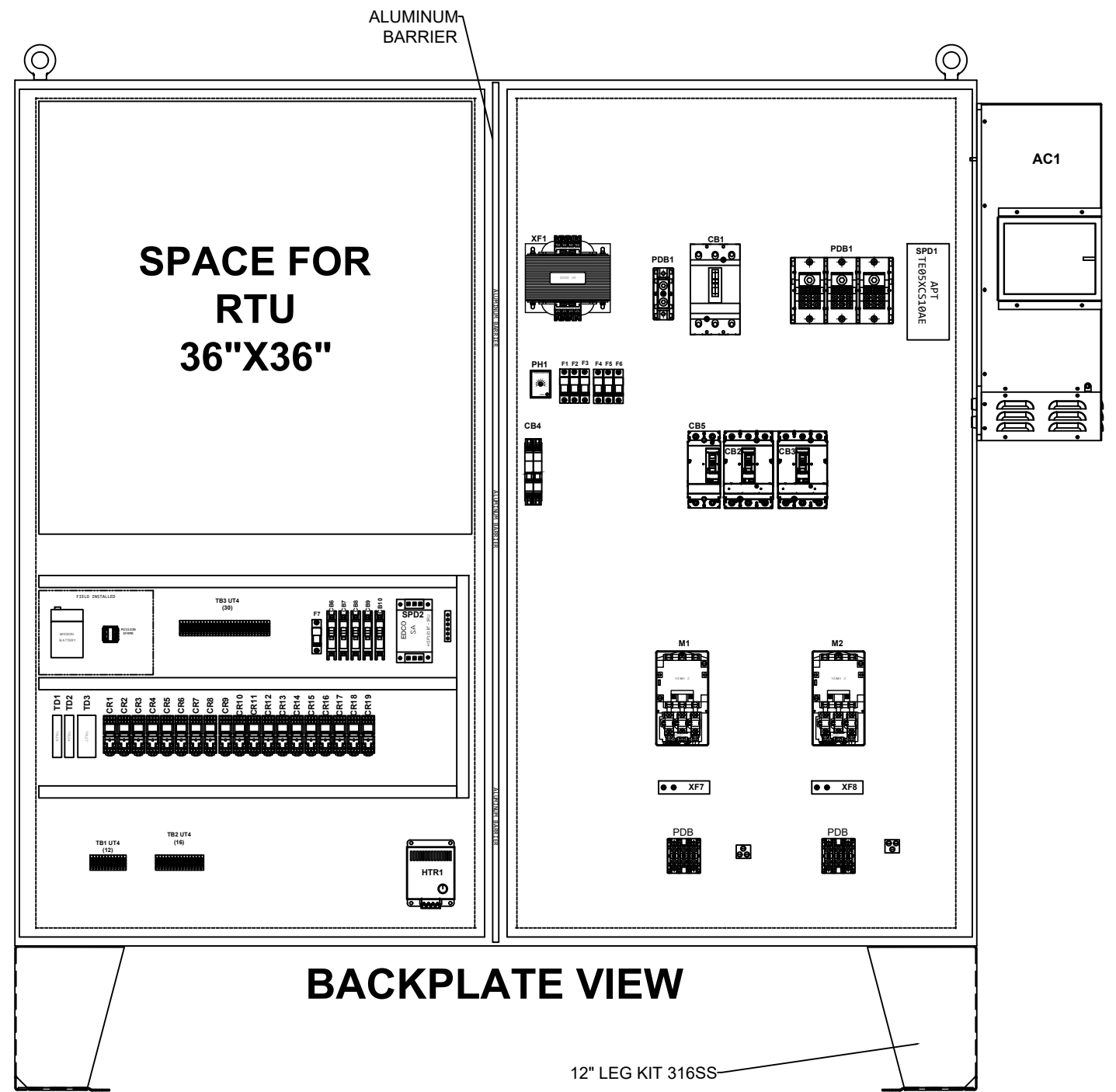

BACKPLATE VIEW

12" LEG KIT 316SS

THIS DRAWING CONTAINS PROPRIETARY INFORMATION WHICH MUST NOT BE DUPLICATED, USED, OR DISCLOSED IN WHOLE OR IN PART WITHOUT PRIOR WRITTEN CONSENT.

SHEET NUMBER
7 OF 7

NO.	REVISION HISTORY	DATE	BY
B	CHANGES PER COMMENTS	7/30/21	RDG
A	SUBMITTAL	4/22/21	RDG



GWINNETT CO, GA
RIVERCLIFF PLACE PS

DRAWN BY
RDG

DATE
4/22/2021

PANEL REQUIREMENTS	
SYM.	
VOLTAGE	230 V
PHASE	3
FREQUENCY	60 HZ
SCCR	10kA RMS SYM
TOTAL FLA	76 A
TYPE	4X

LARGEST MOTOR POWER REQUIREMENTS	
HP	11 HP
FLA	22 A

PROJECT NUMBER
5007010A

TAGS	QTY	IFS	CATALOG	MANUFACTURER	DESCRIPTION	QUERY2	QUERY3
ENCLOSURE	1	1066227	SCE-72EL8218SS6LPPL-	SCE	ENCL,316SS,4X, 72X82X18,2DR,3PTL,SAGINAW, WHITE	ENCL,N4XSS,72X82X18, 2DR,3PTL,SAGINAW,W 4X	
ENCLOSURE	1	1066453	SCE-FK1218SS6-MOD	SCE	FLOOR STAND KIT, 316SS, SAGINAW, 12 X 18 X 9.12 WHITE	FLOOR STAND KIT WHITE	NEMA 4X
ENCLOSURE	2	1031477	SCE-DSTOPK	SCE	DOOR STOP KIT, NEMA 4, 12, STAINLESS, LARGE ENCLOSURE	DOOR STOP KIT	NEMA 4, 12
ENCLOSURE	2	1040575	CPC-INDR-72X72AL	NSI	SWING OUT PANEL, FOR NEMA ENCLOSURES, 72.00 x 36.00 IN, ALUMINIUM	INNER DOOR	WHITE
ENCLOSURE	1	1066226	SCE-72P82	SCE	SUBPANEL, 72 x 82, STEEL,WHITE	SUBPANEL	NEMA 4X
ENCLOSURE	4	1030448	1000-U711	EMKA Inc	QUARTER TURN, LATCH, WING KNOB INSERT	LATCH	ASSEMBLY
ENCLOSURE	4	1030447	1000-991	EMKA Inc	QUARTER TURN, LATCH, CHARGE, ASSEMBLY	LATCH	ASSEMBLY
ENCLOSURE	4	1030446	1000-386-18	EMKA Inc	QUARTER TURN, LATCH, CAM, ASSEMBLY	LATCH	ASSEMBLY
ENCLOSURE	4	1030445	1000-U675	EMKA Inc	QUARTER TURN, LATCH, HOUSING, ASSEMBLY	LATCH	ASSEMBLY
AC1	1	1056134	IQ2000VXS-480-304SS-CP3-N4X-XC	ICE QUBE INC	ICE QUBE, 2000BTU VERTICAL SLIM, 480V, 304 STAINLESS STEEL, TYPE 4X, TOTAL CORROSIVE	2000BTU	SIDE MOUNT
HTR1	1	1004419	DAH1001A	HOFFMAN	HEATER, FORCED AIR, ADJUSTABLE THERMOSTAT, 100W, 115VAC	HEATER	115VAC, 100W
PDB1	1	1035171	1453586	MARATHON	POWER DISTRIBUTION BLOCK, 3-POLE	2x 4-400KCMIL	8x 14-2/0
PDB2,PDB3	2	1030083	1423572	MARATHON	SPLICER BLOCK, 3-POLE	1x 14-2/0	1x 14-2/0
TB1,TB2,TB3,TB4	71	1036508	3044102	PHOENIX CONTACT	UNIVERSAL TERMINAL BLOCK - UT 4	FEED-THROUGH	41AMPS
TB2	6	1038973	3044131	PHOENIX CONTACT	UNIVERSAL TERMINAL BLOCK - UT 6	FEED-THROUGH	57AMPS
GND1,GND2	4	1030204	AU-2/0	ILSCO	GROUND LUG, ALUMINIUM, LUG SIZE 2	GROUND LUG	2x 14-2/0
GND2	2	1025606	TA-250	ILSCO	GROUND LUG, ALUMINIUM, LUG SIZE 3	GROUND LUG	1x 6-250KCMIL
SPD1	1	1041264	TE05XCS104X	APT	SPD, 480V DELTA, 3PH, 100KA, 3 WIRE W/GND	SURGE PROTECTIVE DEVICE	THREE PHASE
SPD2	1	1033844	HSP121BT-1RU	EDCO	SURGE PROTECTIVE DEVICE, DIN MOUNT, SINGLE PHASE, SUPPRESSION	SURGE PROTECTIVE DEVICE	SINGLE PHASE 15A
PH1	1	1034017	70169-D	MACROMATIC	SOCKET, PHASE MONITOR, 8-PIN MOUNTING BASE, SURFACE OR DIN RAIL MOUNT	MOUNTING BASE	PHASE MONITOR
PH1	1	1030949	PMPU	MACROMATIC	PHASE MONITOR, 190-500V, 3P, FULL FEATURED	190-500V	3PHASE
CB1	1	1024471	HDL36125	SQUARE-D	CIRCUIT BREAKER - H FRAME, 125AMP	3-POLE CIRCUIT BREAKER	125AMP

TAGS	QTY	IFS	CATALOG	MANUFACTURER	DESCRIPTION	QUERY2	QUERY3
CB1	1	1039638	S32598	SCHNEIDER ELECTRIC	CIRCUIT BREAKER, DOOR MOUNT HANDLE KIT, N3R, BLACK, L-FRAME	HANDLE KIT	L-FRAME
CB2,CB3	2	1027980	HDL36040	SQUARE-D	CIRCUIT BREAKER - H FRAME, 40AMP	3-POLE CIRCUIT BREAKER	40AMP
CB2,CB3	2	1034452	S29371	SCHNEIDER ELECTRIC	CIRCUIT BREAKER PADLOCK POWERPACT H&J	PADLOCK	H&J FRAME
CB6	1	1005688	QOU115	Allen-Bradley	MINIATURE CIRCUIT BREAKER QOU - 1 POLE - 15A	1-POLE MINIATURE CIRCUIT BREAKER	15AMP
CB9	1	1006488	QOU120	Allen-Bradley	MINIATURE CIRCUIT BREAKER QOU - 1 POLE - 20A	1-POLE MINIATURE CIRCUIT BREAKER	20AMP
CB10,CB7,CB8	3	1003024	QOU110	Allen-Bradley	MINIATURE CIRCUIT BREAKER QOU - 1 POLE - 10A	1-POLE MINIATURE CIRCUIT BREAKER	10AMP
CB4	1	1046193	MGN61349	SCHNEIDER ELECTRIC	MARINE CIRCUIT BREAKER, C60H SERIES, D CHARACTERISTIC, DIN RAIL MOUNTING	3-POLE CIRCUIT BREAKER	5AMP
CB5	1	1030585	HDL26040	SQUARE-D	CIRCUIT BREAKER - H FRAME, 40AMP	2-POLE CIRCUIT BREAKER	40AMP
M1,M2	2	6000825	8536-SDO1V02S	SQD	FULL VOLTAGE MOTOR STARTER NEMA SIZE 2	NON-REVERSING	45AMPS, 120VAC
FU4,FU5,FU6	3	1040042	FNQ-R-20	BUSSMANN	FUSE - CLASS CC, 20AMPS, 600VAC	TIME DELAY	600VAC
FU4	1	1032249	CHCC2DIU	BUSSMANN	2 POLE FUSE BLOCK - CLASS CC WITH INDICATOR, 1/10-30AMPS, 600VAC	FUSE HOLDER	600VAC
FU6,FU7	2	1058883	CHCC1DIU	BUSSMANN	1 POLE FUSE BLOCK - CLASS CC WITH INDICATOR, 1/10-30AMPS, 600VAC	FUSE HOLDER	600VAC
FU1,FU2,FU3	3	1040019	KTK-R-1	BUSSMANN	FUSE - CLASS CC, 1AMP, 600VAC	FAST ACTING	600VAC
FU1	1	1058885	CHCC3DIU	BUSSMANN	3 POLE FUSE BLOCK - CLASS CC WITH INDICATOR, 1/10-30AMPS, 600VAC	FUSE HOLDER	600VAC
FU7	1	6000242	FNQ-R-2	BUSSMANN	FUSE - CLASS CC, 2AMPS, 600VAC	TIME DELAY	600VAC
XF3	1	6000884	9070T2000D1	SQD	INDUSTRIAL CONTROL TRANSFORMER, CLASS 9070, 2KVA, 240X480V-120V, 230X460V-115V, 220X440V-	CONTROL TRANSFORMER	2KVA
XF1,XF2	2	1038330	FCS2151-SP-420E	INGRAM	CURRENT SENSOR, 4-20mA OUTPUT 0-100/150/200	SENSOR	4-20mA
SL1,SL2	2	1022712	P3GA-11	MPE	REVERSE DOOR MOUNT PUMP MONITOR SOCKET	SOCKET	SOCKET
OL1,OL2	6	6000756	B 36.0	SQD	MELTING ALLOY THERMAL UNIT, TABLE 58	STANDARD TRIP (20)	1TU:24.2â€“26.8
OL1,OL2	2	1027432	9066-RA1	TELEMECANIQUE	OVERLOAD RELAY RESET MECHANISM	OVERLOAD RELAY	RESET
OL1,OL2	2	1027511	9999-SO4	SQD	MOTOR O/L, EXTERNAL AUXILLARY CONTACT, 1 NO, 1 NC	AUX CONTACT	1 NO, 1 NC
TD1,TD2	2	1039530	TRL04	EATON	RELAY,TIMING,DIN RAIL,4 FUNCTION,SPDT,24-240V	MULTIFUNTION	24-240V

TAGS	QTY	IFS	CATALOG	MANUFACTURER	DESCRIPTION	QUERY2	QUERY3
TD3	1	1038318	TRL27	Allen-Bradley FSM4 Series	RELAY,TIMING,DIN RAIL,4 FUNCTION,SPDT,24-240V	MULTIFUNCTION	24-240V
ETM1,ETM2	2	1033953	T50B2	ENM COMPANY	ELAPSED TIME METER, QUARTZ AC HOUR METER II, 5 DIGIT HOURS, 1 DIGIT TENTHS	T50	120VAC
CR1,CR10,CR11,CR12,C R13,CR14,CR15,CR16,C	19	1028815	RXZE2M114M	SCHNEIDER ELECTRIC	SOCKET FOR RELAYS TYPE RXM	TYPE RXM	SOCKET
CR1,CR10,CR11,CR12,C R13,CR14,CR15,CR16,C	19	1030214	RXM4AB2F7	SCHNEIDER ELECTRIC	PLUG-IN MINIATURE RELAY, TYPE RXM, SOCKET RXZE2M114M, WITH LED	TYPE RXM	120VAC
SS1,SS2	2	1040193	9001-SKS43BH2	SQD	SELECTOR SW - 3 POS MAINT, NEMA 4X/13	30.5mm	BLACK KNOB
TG1,TG2	2	1027363	8911K10	EATON	PUSHBUTTON ASSEMBLY,1NC BLACK, INTRUSION SWITCH	NA	NA
LT1,LT2	2	1038297	LEDA1S35	HOFFMAN	LIGHT, LED, PANEL MOUNT, SCREW MOUNT, ON-OFF SWITCH, 60-260VAC	PANEL MOUNT	60-260VAC
LT3,LT5,LT6,LT7,LT8	5	1040606	9001SKT1LRR31	TELEMECANIQUE	LGT,PIL,30MM,P/TEST,RED,LED,XFMR,120VAC	30mm	120V
LT4	1	1041065	9001SKT38LWW31	TELEMECANIQUE	LGT,PIL,30MM,P/TEST,WHITE,LED,XFMR,120VAC	30mm	120V
RECPT1	1	1040368	GF15WLA	Phoenix	DUPLEX RECEPTACLE, GFCI, WHITE, 2 POLE, 3-WIRE	15 AMP	125 VOLT
CT1	1	1054608	14344-M-113	XYLEM, CUSTOMER SUPPLIED	CSP-RTU,MISSION WIRELESS M-113,FLATPACK,N1	RTU/SCADA	CUSTOMER SUPPLIED
SL1,SL2	2	1056989	14344 14-407129	CUSTOMER SUPPLIED, XYLEM	COMPACT SUBPLATE MOUNT ASSEMBLY, MINICAS 120, PUMP MONITOR RELAY, SEAL LEAK ALARM,	RELAY	MOISTURE
LITERATURE	2	1005652	1005652	PRIMEX	LITERATURE, SCHEMATIC	LITERATURE	SCHEMATIC
LITERATURE	2	1055251	1055251	PRIMEX	LABEL ASSEMBLY, UL/cUL 698A	LABEL	UL/cUL 698A
LITERATURE	2	1051683	1051683	SJE-RHOMBUS	LABEL, UL, 698A	UL	ASSEMBLY
LITERATURE	2	1040972	6674002	FLYGT	FLYGT STICKER 230 X 160 BLUE, LARGE	LABEL	LOGO



SPARE PARTS - SHIP LOOSE

TAGS	QTY	IFS	CATALOG	MANUFACTURER	DESCRIPTION	QUERY2	QUERY3
PH1	1	1030949	PMPU	MACROMATIC	PHASE MONITOR, 190-500V, 3P, FULL FEATURED	190-500V	3PHASE
M1	1	6000825	8536-SDO1V02S	SQD	FULL VOLTAGE MOTOR STARTER NEMA SIZE 2	NON-REVERSING	45AMPS, 120VAC
FU3	5	1040019	KTK-R-1	BUSSMANN	FUSE - CLASS CC, 1AMP, 600VAC	FAST ACTING	600VAC
FU2	5	6000242	FNQ-R-2	BUSSMANN	FUSE - CLASS CC, 2AMPS, 600VAC	TIME DELAY	600VAC
FU1	5	1040042	FNQ-R-20	BUSSMANN	FUSE - CLASS CC, 20AMPS, 600VAC	TIME DELAY	600VAC
OL1	3	6000756	B 36.0	SQD	MELTING ALLOY THERMAL UNIT, TABLE 58	STANDARD TRIP (20)	1TU:24.2"26.8
CR1	5	1028815	RXZE2M114M	SCHNEIDER ELECTRIC	SOCKET FOR RELAYS TYPE RXM	TYPE RXM	SOCKET
CR1	5	1030214	RXM4AB2F7	SCHNEIDER ELECTRIC	PLUG-IN MINIATURE RELAY, TYPE RXM, SOCKET RXZE2M114M, WITH LED	TYPE RXM	120VAC
LT1	5	1040606	9001SKT1LRR31	TELEMECANIQUE	LGT,PIL,30MM,P/TEST,RED,LED,XFMR,120VAC	30mm	120V
LT2	5	1041065	9001SKT38LWW31	TELEMECANIQUE	LGT,PIL,30MM,P/TEST,WHITE,LED,XFMR,120VAC	30mm	120V